

Roger Access Control System

MC16-PAC-1-KIT Installation Manual

Controller firmware version: 1.6.2 or newer

Product version: 2.0

Document version: Rev. C



This document contains minimum information that is necessary for initial setup and installation of the kit. The detailed description of configuration parameters and functionalities of all components is specified in respective Operating manuals available at www.roger.pl.

INTRODUCTION

MC16-PAC-1-KIT is designed to control single door in RACS 5 system. The door can be read-in or read-in/out type when equipped with MCT series readers (RS485), PRT series readers (RACS CLK/DTA) or Wiegand interface readers. The kit includes MC16-PAC-1 access controller and ME14-24V metal box with 24VDC/50W power supply unit. The box is adapted to installation of 7Ah battery for emergency supply. All elements of controlled door including readers and door lock can be supplied from the kit.

CONFIGURATION WITH ROGERVDM PROGRAM

Low level configuration with RogerVDM software enables to define basic parameters of MC16 controller. Additionally in case of MCT and PRT series readers it is necessary to define their individual addresses according to their installation manuals.

MC16 programming procedure with RogerVDM software:

1. Connect the controller to Ethernet network and define the IP address of your computer in the same subnetwork as the controller with 192.168.0.213 default IP address.
2. Start RogerVDM program, select *MC16 v1.x* device, the latest firmware version and *Ethernet* communication channel.
3. Select from the list or enter manually the IP address of controller, enter 1234 communication key and start the connection with the controller.
4. In the top menu select *Tools* and then *Set communication key* to define your own password for the controller.
5. In the main window specify your own IP address of the controller.
6. Enable PRT or Wiegand readers if the controller is supposed to operate with them
7. Optionally enter comments for controller and its object to facilitate their identification during further configuration of the system.
8. Optionally backup settings clicking *Send to File...*
9. Click *Send to Device* to update the configuration of controller and disconnect by selection of *Device* in the top menu and then *Disconnect*.

CONFIGURATION WITH VISO PROGRAM

High level configuration with VISO software enables to define the logic of controller. More information is given in MC16 Operating manual and AN006 application note.

MEMORY RESET

Memory reset procedure resets all settings to default ones and results in 192.168.0.213 IP address and empty communication key.

MC16 memory reset procedure:

1. Disconnect power supply
2. Short CLK and IN4 lines.
3. Restore power supply, all LEDs will flash and wait min. 6s.
4. Remove connection between CLK and IN4 lines, LEDs will stop pulsating and LED2 will be on.
5. Wait approx. 1.5 min till LED5+LED6+LED7+LED8 are pulsating.
6. Restart the controller (switch power supply off and on)
7. Start RogerVDM and make low level configuration.

FIRMWARE UPDATE

New firmware can be uploaded to the controller with RogerVDM software. The latest firmware file is available at www.roger.pl.

MC16 firmware update procedure:

1. Connect with the controller using RogerVDM software.
2. Backup settings by clicking *Send to File...*
3. In the top menu select *Tools* and then *Update firmware*.
4. Select firmware file and then click *Update*.
5. After firmware update wait till LED8 is pulsating.
6. Make or restore low level configuration in RogerVDM software.

Note: During the firmware update process, it is necessary to ensure continuous and stable power supply for the device. If interrupted, the device may require repair by Roger.

POWER SUPPLY

The kit is supplied from 24VDC/50W power supply unit. The metal box offers space for installation of typical 7Ah backup battery which is connected to BAT+ and BAT- terminals of MC16 controller.

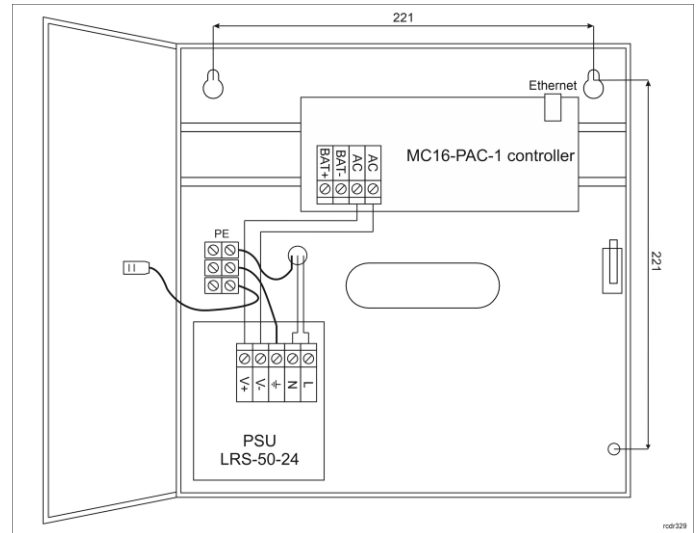

Fig. 1 MC16-PAC-1-KIT

	The installation can be done only by qualified person with all necessary certificates concerning connection and maintenance of 230VAC and low voltage networks.
	Prior to starting the installation it is necessary to ensure that 230 VAC circuit is disconnected. All works inside the box must be carried out with 230VAC supply voltage disconnected.
	It is forbidden to use the kit without properly executed and operational earthing system.

TAMPER DETECTOR

The metal box is equipped with door contact which can be connected to one of the inputs (e.g. IN8) and GND terminal of the controller. The anti-sabotage function can be assigned to the input within high level configuration of the system.

APPENDIX

Table 1. MC16 screw terminals	
Name	Description
BAT+, BAT-	Backup battery
AC, AC	18VAC input power supply
AUX-, AUX+	12VDC/1.0 output power supply (for door lock)
TML-, TML+	12VDC/0.2A output power supply (for readers)
IN1-IN8	Input lines
GND	Ground
OUT1-OUT6	15VDC/150mA transistor output lines
A1,B1	RS485 bus
CLK, DTA	RACS CLK/DTA bus
A2,B2	Not used
NO1, COM1, NC1	30V/1.5A DC/AC (REL1) relay
NO2, COM2, NC2	30V/1.5A DC/AC (REL2) relay

Table 2. MC16 LED indicators	
Name	Description
LED1	Normal mode
LED2	ON: Service mode (low level configuration) Pulsing: RAM or Flash SPI memory error
LED3	ON: High level configuration error Pulsing: Low level configuration error

LED4	No memory card or memory card error
LED5	Event log error
LED6	License error
LED7	Not used
LED8	Pulsating: Proper functioning of the controller

Supply voltage	230VAC, 50/60Hz (-15%+10%)
Power supply	LRS-50-24 24VDC/50W
Short circuit and overload protection	Yes
Metal box	DC01 0.8mm metal sheet, grey anthracite colour (RAL7016)
Tamper protection	NO/NC detector, 50VDC/50mA
Distances	Up to 150 m between kit and readers
IP Code	IP20
Environmental class (acc. to EN 50133-1)	Class I, indoor general conditions, temperature: +5°C to +40°C, relative humidity: 10 to 95% (no condensation)
Dimensions H x W x D	255 x 255 x 90 mm
Weight	1,7 kg
Certificates	CE

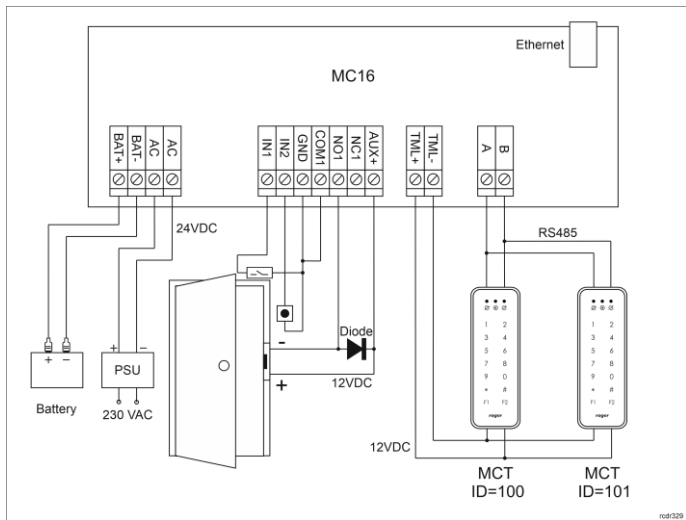

Fig. 2 Typical door control with MCT readers

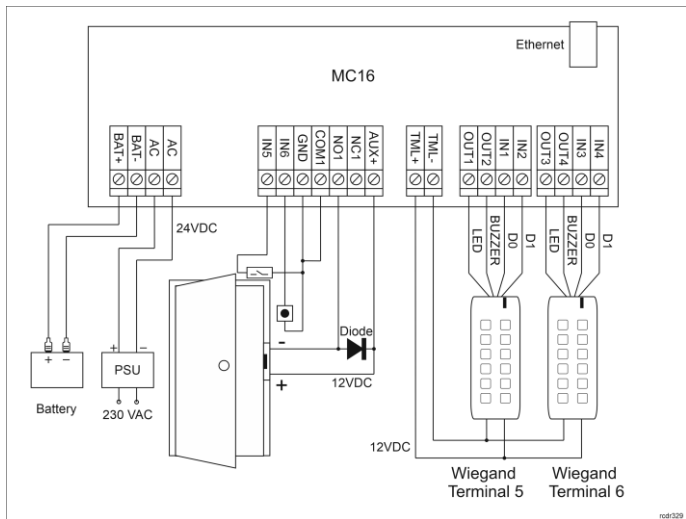
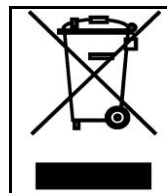

Fig. 2 Typical door control with Wiegand readers

Notes:

- In case of read-in door, single reader is connected to the controller. MCT terminal can be then configured with default ID=100 address.
- In case of PRT readers, the diagram is the same as in case of MCT readers except for connection to CLK and DTA lines instead of RS485 A and B lines.
- In case of electrically incompatible Wiegand readers it might be necessary to install PR-GP-BRD modules.
- Diagrams include doors with electric strikes. In case of electromagnetic lock, the NC terminal of relay is used instead of NO terminal.
- Diagrams include exit buttons. In case of read-in/out doors they can be used for emergency door opening.



This symbol placed on a product or packaging indicates that the product should not be disposed of with other wastes as this may have a negative impact on the environment and health. The user is obliged to deliver equipment to the designated collection points of electric and electronic waste. For detailed information on recycling, contact your local authorities, waste disposal company or point of purchase. Separate collection and recycling of this type of waste contributes to the protection of the natural resources and is safe to health and the environment. Weight of the equipment is specified in the document.

Contact:
Roger Sp. z o. o. sp. k.
82-400 Sztum
Gościszewo 59
Tel.: +48 55 272 0132
Fax: +48 55 272 0133
Tech. support: +48 55 267 0126
E-mail: support@roger.pl
Web: www.roger.pl