

SDC66 Electronic Card-Operated Lock

Firmware version v1.02.35
Document version: Rev.G



Introduction

The card-operated lock allows the electronic control of door/gate passage using the contactless **Prox-keys**. The lock finds application wherever it is necessary to limit the number of individuals, who can enter a room, at the same time releasing them from the need to use many traditional mechanical keys. The need for such a solution usually occurs in public places such as schools, offices, shops, hospitals etc. The SDC66 lock is most often used to protect various lockers, utility rooms, gates, entrances, toilets and other rooms with relatively low level of anti-burglary protection. The SDC66 lock may also be used in private homes, thus relieving its occupants of the need to carry multiple traditional keys. The SDC66 was developed so that its installation and activation can be performed by the professional electrician-fitter as well as by those with no professional preparation but with some DIY skills. The device can be installed both indoors and outdoors.

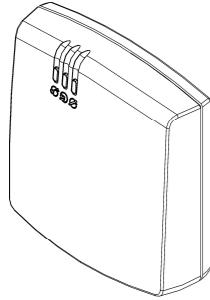

Features

- Works with contactless **Prox-keys**
- Possibility of programming up to 120 **Prox-keys**
- Selective enrollment and removal of **Prox-keys**
- Support for **Door Contact** and **Exit Button**
- **Door Alarm** signaling
- Indoor and outdoor operation
- 12V DC/AC power supply
- Anti-sabotage protection (tamper)

Lock Installation – Minimal Variant

Upon installation according to the diagram in Fig. 1 (variant with the electric door strike and powering up, the lock is ready for operation. The lock is delivered with 5 **Prox-keys**, which are programmed to device memory and can be distributed among the users. When the **Prox-key** is placed close to the front of the reader the door is unlocked for approx. 2s.

Lock Installation – Extended Variant

The extended variant allows the use of extra components of the access control system that may optionally consist of: **Exit Button**, **Alarm Siren**, and **Door Contact**. The presence of each of the mentioned components is not necessary and can be omitted depending on the individual requirements of a specific installation. Upon assembling of the unit according to the diagram in Fig. 2 and powering up, the access control system is ready for operation. Like in the minimum variant of the installation, the use of any of the 5 **Prox-keys** will unlock the door for approx. 2s.

Description of System Components

Power Supply

The SDC66 set is equipped with 12V/20VA mains transformer which can be used to supply both: the SDC66 lock and the locking device (door strike). The maximum current which can be drawn from the AC transformer must not exceed 1.5A. If necessary, system can be supplied from another source of power however the supply voltage must be within range indicated in this manual (see Technical Data section later in this document). Optionally, system can be supplied from 12VDC power supply equipped with reserve battery to keep system running in case of AC supply failure. When supplying from 12VDC use wiring as presented on Fig.3.

Note: Eventually, the 12V/20VA transformer can be installed inside flush box beneath SDC66 plastic case however it is allowed solely in internal location where there is no risk that it can be penetrated by water on any other liquids. Generally, it is installer responsibility to select proper location and installation method of 12V/20VA mains transformer in order to provide adequate protection against electrical shock.

Door Lock

It is the electric door strike or electro-magnetic lock that is most often used for electric door locking. While the electric door strike releases a door after the supply is applied to a door lock, then the electro-magnetic lock is normally energized (under supply) and the door opens only when supply is discontinued. Both, the electric door strike and the electro-magnetic lock are inductive type elements and have to be accompanied with a semiconductor diode connected as close as possible to the lock element (see D1 element on the assembly drawings hereinafter).

Note: Both figures included in this document present wiring method for the door strike locking device nevertheless, it is possible to use electromagnet door lock (or any other type of locking device which normally is energized) however in such a case the NC relay contact should be used instead of NO terminal. The rest of wirings are in both cases the same.

Door Contact

The **Door Contact** is an optional component. The use of this element allows monitoring the current door status and thus signaling an **Door Alarm** state is possible. The **Door Contact** should be installed in such a manner that its contacts are shorted when monitored door is closed. The **Door Contact** sensor should be

connected between the GND-IN1 terminals. However, if it is not installed, then the GND and IN1 terminals must be shorted.

Exit Button

The use of the **Exit Button** unlocks the door for the same duration as upon the readout of an authorized **Prox-key**. The generally available door bell buttons, temporary lighting buttons or other buttons that automatically return to their off position upon removing the hand may be used as the **Exit Button**. Normally, when the button is not pressed, the **Exit Button** contacts should be open.

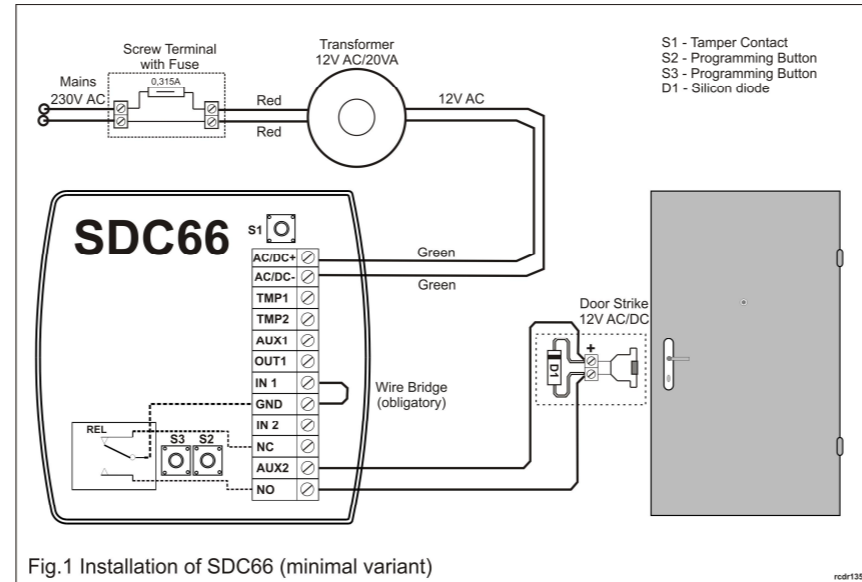

Fig.1 Installation of SDC66 (minimal variant)

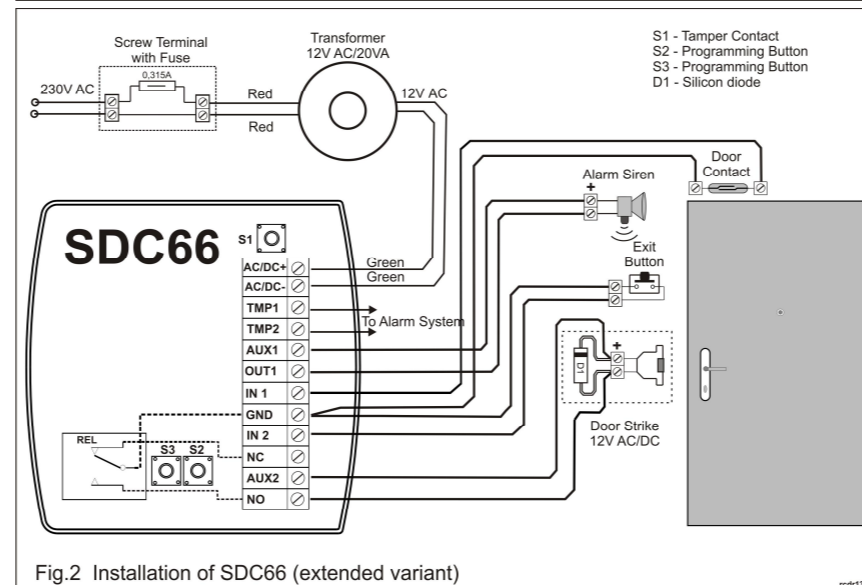

Fig.2 Installation of SDC66 (extended variant)

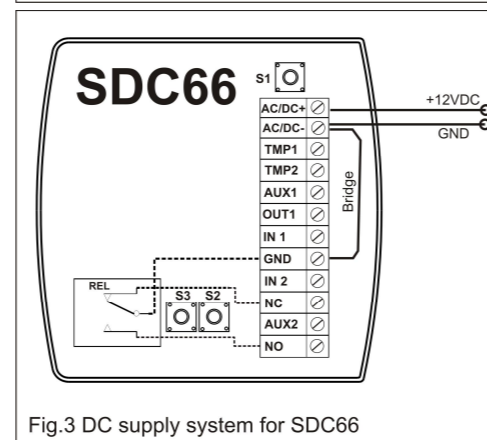

Fig.3 DC supply system for SDC66

Note: The current consumption of the SDC66 lock itself is relatively low (app. 50 mA) but for the calculation of power supply system the current drawn by the electric door lock and optional alarm signaling device, if any,

should be taken into consideration. In some cases, it might happen that more powerful source of power will be necessary.

Alarm Signals

Adding an alarm siren or another signaling device to the reader allows the **Door Alarm** state to be signaled. The reader activates the **Door Alarm** signal upon opening the door without the use of a valid **Prox-key** or **Exit Button**, or upon granting access the door is not closed within the **Entry Time**. A signaling device (e.g. piezo alarm siren), which requires the power supply of 12VDC and current up to 0.5A, can be connected to the reader output (as indicated on included wirings diagrams).

Anti-sabotage Contact

The S1 anti-sabotage contact (tamper) enables protecting the lock against an attempt to open the housing or tear it off the place of installation. The anti-sabotage contact is available on TMP1 and TMP2 screw terminals and should be attached to the alarm system or any other device which is dedicated to indicate tamper situation.

Programming

A brand new lock is already pre-programmed and responds to **Prox-keys** included in the set. In most cases, it will be unnecessary to carry out any extra programming activities. However, when necessary the new **Prox-keys** can be added to the system. The other reader settings, including the door unlocking time (**Entry Time**) or alarm signal duration (**Alarm Time**), can be changed as well. See below for the programming procedures available in the SDC66 reader.

*Note: When configuration of the reader is incorrect, unit signals this situation with pulsing LED STATUS (green/red color alternately). When this symptom occurs, the so called **Memory Rest** procedure should be carried out to restore reader's operation (see **Memory Rest** later in this document).*

*Note: You will need a MASTER card to make the programming. The MASTER card is supplied with a new device however when lost or damaged the new MASTER card can be programmed to the lock (see **Memory Reset** procedure).*

Adding Prox-keys

- Read the MASTER card twice, the reader will illuminate the LED STATUS (in green) and after 6 seconds it will activate LED SYSTEM (orange) as well
- Put a new **Prox-key** (the one you want to add to the system) close to the reader and the reader will confirm the readout with an acoustic OK signal (3 pulses)
- Repeat the previous step for every new **Prox-key** or move to next step
- Wait approx. 15s, the reader will exit the programming mode and restore its normal operation (the STATUS LED will change color to red again)
- Test the operation of the newly added **Prox-keys**

*Note: The reader allows programming up to 120 **Prox-keys**. Any attempt to add a **Prox-key** above this limit will trigger an error signal (long audio signal).*

*Note: If there is a **Prox-key** already registered in the reader's memory, the reader will give an acoustic error signal (long audio signal) and exit the programming mode.*

Removing Prox-keys

- Read the MASTER card three times, reader will illuminate LED STATUS (in green) and after 6 seconds LED SYSTEM will start pulsing
- Hold a **Prox-key** (the one you want to remove from the memory) close to the reader for a while and the reader will confirm its removal with an acoustic OK signal (3 pulses)
- Repeat the previous step for every **Prox-key** you want to remove or move to next step
- Wait approx. 15s, the reader will exit the programming mode and restore its normal operation (the LED STATUS will change color to red again)
- Check whether the **Prox-key(s)** is successfully removed from the reader

*Note: If you try to remove not-programmed **Prox-key** will give an acoustic error signal (long audio signal) and exit the programming mode.*

Removing All Prox-keys

- Read the MASTER card four times, the reader will start illuminating the STATUS LED (in green) and after 6 seconds the SYSTEM LED (orange) and the STATUS LED will start pulsing
- The reader will give an acoustic continuation signal (double short signal)
- When the STATUS LED and SYSTEM LED are pulsing put again the MASTER card close to the reader and keep it until the reader starts generating short sound pulses (min. 5 sec.), then take away the MASTER card from the reader
- Reader will delete all existing **Prox-keys** and then leaves programming mode (it generates an acoustic OK signal which consist of 3 pulses) and restores its normal operation

Setting Entry Time

The **Entry Time** is the time duration for which the lock remains unlocked upon access is granted.

- Open the housing of the device
- Read the MASTER card twice, reader will illuminate the STATUS LED (in green) and after 6 seconds the SYSTEM LED (orange)
- Press and keep pressed the S2 key for exactly as long as the door would be unlocked. When the key is kept pressed the reader will be generating acoustic signal every second. The minimum duration for which the lock remains open is 2s.
- Release the S2 key, the reader will store the programmed time and automatically exit the programming mode

Setting Alarm Time

The **Alarm Time** determines for how long the lock will activate the alarm output in case of **Door Alarm** state.

- Open reader's case

- Read the MASTER card twice, the reader will activate STATUS LED (in green) and then after 6 seconds the SYSTEM LED (orange)
- Press and keep pressed the S3 key and at the same time count the acoustic signals generated by the reader – each signal corresponds to the increase in alarm time by another 10s
- Release the S3 key and the reader will automatically exit the programming mode

Example 1

To program the **Alarm Time** of 50s, wait until reader generates 5 audio signals and then release the S3 key.

Example 2

To program the alarm time of 3 minutes, wait until the reader generates 18 audio signals (18 x 10s = 180s = 3 minutes) and then release the S3 key.

Memory Reset – Erasing reader memory and programming of a new MASTER card

The **Memory Reset** operation erases the entire contents of reader memory (including the previously programmed prox-keys and time settings) and allows for the enrollment of the new MASTER card. To make the **Memory Reset** follow these steps:

- Switch off the power
- Open reader's case
- Disconnect any cables connected to OUT1 and IN2 lines
- Short OUT1 and IN2 lines
- Restore power
- Reader will activate all LEDs and continuous sound will be generated
- Remove connection between OUT1 and IN2 lines
- Reader will stop acoustic sound and only OPEN LED will be pulsing
- Read a prox card you want to be a new MASTER card
- Upon the new MASTER card is enrolled, reader will generate the OK signal (three short acoustic signals) and switch to normal work
- Restore the original connections to the OUT1 and IN2 lines
- Close the housing and test the reader operation, note that after **Memory Reset** Entry Time=2s and Alarm Time=60s

*Note: Once the **Memory Reset** operation has been completed, the reader accepts all **Prox-keys** (Roger item: EMKF-4), which means in practice that any EMKF-4 type keyfob will unlock the door even when it is not earlier programmed into the device. Practically, it creates opportunity to use unlimited number of **Prox-key** with SDC66. However, if you add the new **Prox-key** using **Adding Prox-key** procedure, reader will only accept those **Prox-keys** which were individually programmed to the unit.*

Optical Signals

LED-s	Description	Meaning
	STATUS LED is ON (red) OPEN LED is OFF SYSTEM LED is OFF	Normal operating mode
	STATUS LED is ON (red) OPEN LED is ON SYSTEM LED is OFF	OPEN LED lights for the entire time when door lock is released
	STATUS LED is ON (red) OPEN LED is OFF SYSTEM LED is BLINKING	SDC66 is signaling Door Alarm state
	STATUS LED is OFF OPEN LED is OFF SYSTEM LED is active for 2 seconds	Access denied because Prox-key is not valid
	STATUS LED is ON (red and green alternately) OPEN LED is OFF SYSTEM LED is OFF	Reader memory is corrupted - perform Memory Reset and program the reader a new to clear the problem

LED-s	Description	Meaning
	STATUS LED is ON (green) OPEN LED is OFF SYSTEM LED is OFF	Reader is currently in programming mode
	STATUS LED is ON (green) OPEN LED is OFF SYSTEM LED is ON	Reader is now in Adding Prox-key procedure
	STATUS LED is ON (green) OPEN LED is OFF SYSTEM LED is BLINKING	Reader is now in Removing Prox-key procedure
	STATUS LED is BLINKING (green) OPEN LED is OFF SYSTEM LED is BLINKING	Reader is now in Removing all Prox-key procedure
	STATUS LED is ON OPEN LED is ON SYSTEM LED is ON	Memory Reset in progress
	STATUS LED is INOFF OPEN LED is pulsing SYSTEM LED is OFF	Waiting for the new MASTER card (during Memory Reset procedure)

Acoustic Signals

Buzzer	Description	Meaning
	"Error" signal: continuous acoustic signal of 2 sec.	Function performance error, unknown card access, access denied.
	"Go ahead" signal: 2 short acoustic signals.	The expiration of successive seconds when in the Entry Time definition mode; the expiration of successive 10 sec. when in the Alarm Time definition mode; waiting for another 4-time MASTER card readout when in the Removing All Prox-keys mode.
	"OK" signal: series of 3 short acoustic signals.	Correct function performance, card acceptance, access granted.
	"Restart" signal: series of 5 short acoustic signals.	Controller restarts after a power supply failure or after a reader reset (defining a new MASTER card).

SDC66 Set

This factory new SDC66 set includes:

- SDC66 reader
- Flush box
- MASTER card (Roger item: EMC-7), 1 pcs
- Prox-keys (Roger item: EMKF-4), 5 pcs
- 12V AC transformer with screw terminal and fuse
- Instruction manual

Accessories

Symbol	Description
EMKF-4	Prox-key for SDC66 lock – keyfob form
EMC-7	MASTER card (MASTER logo printout)
EMC-10	Prox-key for SDC66 lock – ISO card form
PS10	12VDC power supply
EP7-12	7Ah/12V reserve battery for PS10
ASP110LC	Alarm siren with light

Technical Data

Parameter	Characteristics	Remarks
Supply voltage	12V AC/DC	Allowable 10..15V AC/DC
Current consumption	50mA	SDC66 electronic module only
OUT1 line current	1A	When active this line switches to ground (power supply minus), when passive remains in high resistance.
AUX1 and AUX2	1A	Unswitched +12V DC output. Total current sourced at the same time from AUX1 and AUX2 lines cannot exceed 1A. AUX1 and AUX2 provide un-switched, positive power supply output for auxiliary equipment (e.g. door lock, siren).
Anti-sabotage (tamper) contact	Isolated NC contact, 50mA/24V, IP67	
Reading distance	Up to 12 cm	
Proximity cards/keys	EMKF-4, EMC-10	
Environmental class (according to EN 50131-1)	Class IV, outdoor-general, temperature: -25°C- +60°C, relative humidity: 10 to 95% (non condensing)	
Dimensions	85x85x27mm	
Weight	≈120g	
Certificates	CE	

Product History

Hardware	Firmware	Date	Description
v1.0	fv1.02.35	05/08/2010	Initial product version

	This symbol placed on a product or packaging indicates that the product should not be disposed of with other wastes as this may have a negative impact on the environment and human health. The user is obliged to deliver the used equipment to the designated point of collection of used electric and electronic equipment. For detailed information on recycling contact your local authorities, waste disposal company or point of purchase. Separate collection and recycling of this type of wastes contributes to the protection of the natural resources and is safe to health and the environment. For the equipment weight see the instruction manual.
--	---

Contact
Roger sp. z o.o. sp. k.
82-400 Sztum
Gościszewo 59
Tel.: +48 55 272 01 32
Fax: +48 55 272 01 33
PSTN technical support: +48 55 267 01 26
Pomoc techniczna GSM: +48 664 294 087
e-mail: support@roger.pl