

OUTDOOR SIREN WITH BEACON TYPE ASP110S AND ASP110PX

GENERAL DESCRIPTION

ASP110 sirens are designed for use in intruder alarm system and others which require acoustic and light signalization, both types of siren utilize piezo-acoustic sound transducer. The ASP110 sirens deliver acoustic signal on app. 110 dB level at 1 meter distance with few modulation tones available and pulsed alarm light signal. Siren top and bottom part are manufactured from robust white polycarbon (PC) or gray ABS plastic, the optional metal protection cover (1.5mm thick) can be located inside siren. Electronic circuit is protected from moisture and corrosion with synthetic layer which cover bottom side of printed circuit board. Light signalization is delivered by xenon flash tube (ASP110PX) which is located in separate compartment with IP65 protection degree or 5W bulb (ASP110S). The light cover is manufactured from polycarbon (PC) and can be delivered in red, blue or amber color, if required light cover can be easy replaced by installer. Electronic circuit has two connectors for optional 12V/1.2Ah battery which should be mounted inside siren cabinet, the battery charging current is internally controlled by ASP electronics. For proper battery charging level the full supply voltage (14VDC) is required. The ASP siren is equipped with TIMER function which automatically terminate acoustic signalization after predefined time, the *Short* (app. 5 minutes) ,*Middle* (app. 10 minutes) or *Long* (app. 15 minutes) signalization time can be selected, timer function can be switch on/off by means of *TIMER ON/OFF* jumper.

Notice: Every trigger signal from control panel resets internal TIMER. The TIMER can not stop a new alarm it can only reduce duration of alarm which occurred previously.

TRIGGERING METHODS

The ASP110 sirens have separate inputs for acoustic and light signalization (inputs *SIREN* and *STROBE*). Both inputs have the same electrical structure and have the same method of triggering. Both inputs has an input resistance of about 5 kOhm and can be driven from low current outputs (signal outputs). Each input line (*STROBE* and *SIREN*) can be triggered using different methods, installer may select if the input must be triggered by NO/NC contact or by High/Low input signal level. Installer may also select if input have to be triggered when voltage is disconnected from input or when voltage is applied to an input (for triggering circuit details see drawings attached to this manual). The ASP can be also triggered automatically by internal TAMPER circuit, this can be achieved by *Auto Trigg. On/Off* jumper. When this jumper is closed siren will be triggered automatically when internal anti-tamper circuit detects one or more TAMPER situation.

TAMPER PROTECTION

ASP110 siren utilize new method of tamper protection based on Infra-Red beam and hermetically sealed tamper contacts. Such a circuit can detect following tamper circumstances:

- Siren cover detached

- Siren detached from wall
- Any obstacle (e.g. foam) above piezo-acoustic transducer
- Lack of power supply (this feature operates only if siren ist equipped with internal battery)

Normally tamper contacts are closed (relay is activated), when tamper situation occurs the relay is deactivated and contact became open.

INSTALLATION

Siren should be fixed firmly on the wall using 5 screws (delivered together with siren) with strobe cover towards ground. Four screws are used to fix siren bottom to wall, the fifth one is used for tamper detection in case when siren is being detached from installation place. All electrical connection should be done without power supply.

Attention : In order to avoid electrical shock disconnect siren supply before service operation. Some electronic parts of xenon flash circuit can have high voltage potential even few minutes after power disconnection, avoid contact with it.

TECHNICAL SPECIFICATIONS

Supply	10.5...15VDC, nominal 13.8V DC
Current consumption:	
▪ stand by	app. 60mA
▪ strobe	avg. 500mA for ASP110S and 300mA for ASP110PX
▪ siren	avg. 200mA
Acoustic signalization frequency	1500...3300Hz
Acoustic signalization	Piezoelectric transducer 110dB at 1 meter
Light signalization	Xenon tube 1J flash energy for ASP110PX 5W bulb for ASP110S
Dimensions	220 X 205 X 80
Weight :	0.75kG

ASP110S AND ASP110PX SIREN/STROBE TRIGGERING METHODS

06.12.02
ACD099EN

ASP110S OR ASP110PX CONTROL PANEL

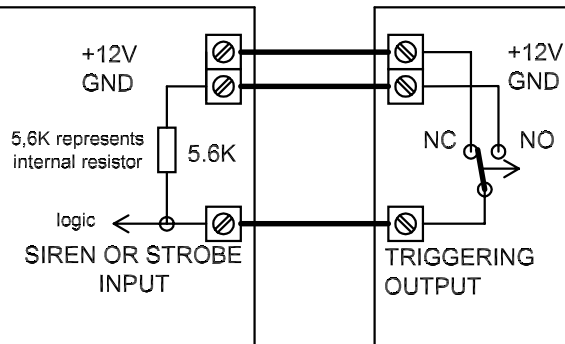

ASP110S OR ASP110PX CONTROL PANEL

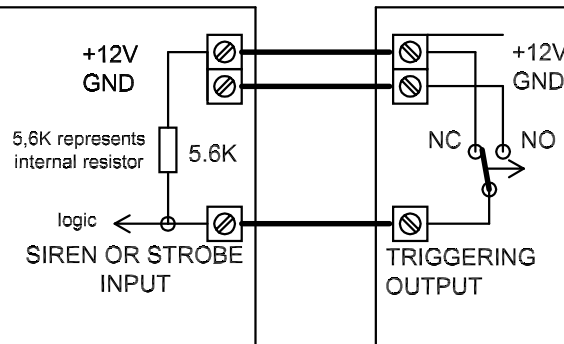

JUMPER SETTINGS

SIREN	SIREN LOW	<input checked="" type="checkbox"/>
	SIREN HIGH	<input type="checkbox"/>

STROBE	STROBE LOW	<input checked="" type="checkbox"/>
	STROBE HIGH	<input type="checkbox"/>

Triggering output normally connected to +12V, Siren/Strobe will be activated when connection with +12V is discontinued.

JUMPER SETTINGS

SIREN	SIREN LOW	<input type="checkbox"/>
	SIREN HIGH	<input checked="" type="checkbox"/>

STROBE	STROBE LOW	<input type="checkbox"/>
	STROBE HIGH	<input checked="" type="checkbox"/>

Triggering output normally connected to GND, Siren/Strobe will be activated when connection with GND is discontinued.

ASP110S OR ASP110PX CONTROL PANEL

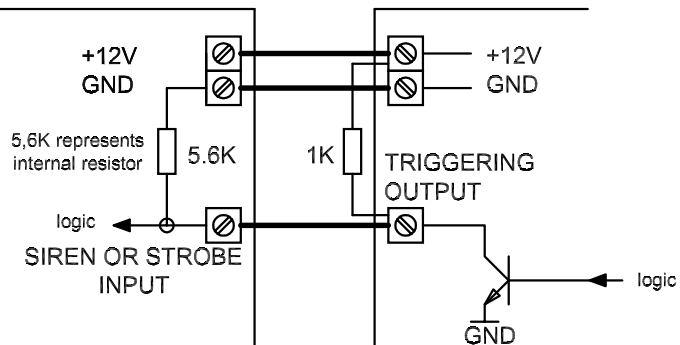

ASP110S OR ASP110PX CONTROL PANEL

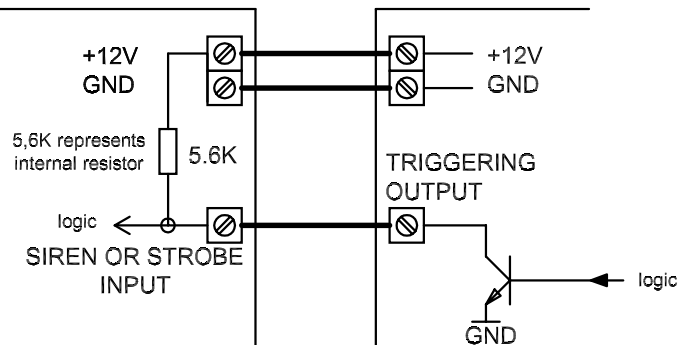

JUMPER SETTINGS

SIREN	SIREN LOW	<input checked="" type="checkbox"/>
	SIREN HIGH	<input type="checkbox"/>

STROBE	STROBE LOW	<input checked="" type="checkbox"/>
	STROBE HIGH	<input type="checkbox"/>

Note: The 1K resistor should be located at Control Panel connection terminals.

Normally transistor remains in OFF state, the transistor ON state will trigger signalization.

JUMPER SETTINGS

SIREN	SIREN LOW	<input type="checkbox"/>
	SIREN HIGH	<input checked="" type="checkbox"/>

STROBE	STROBE LOW	<input type="checkbox"/>
	STROBE HIGH	<input checked="" type="checkbox"/>

Normally transistor remains in ON state, the transistor OFF state will trigger signalization.

ASP110S AND ASP110PX SIREN/STROBE TRIGGERING METHODS

06.12.02
ACD098

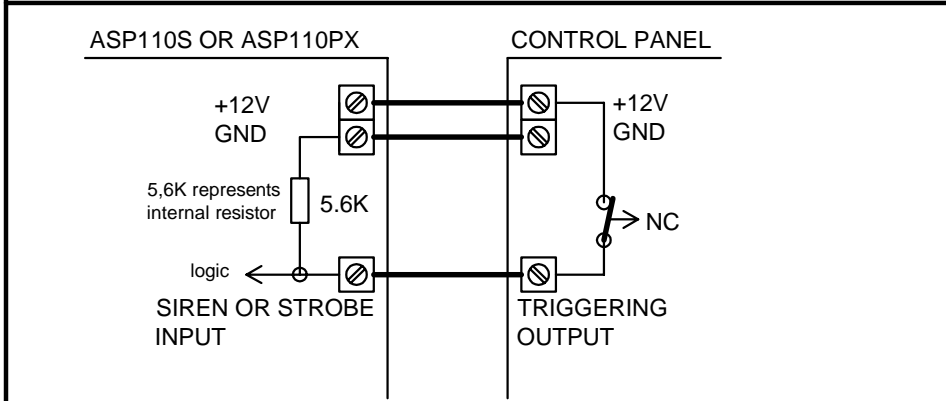

JUMPER SETTINGS	
SIREN	SIREN LOW <input checked="" type="checkbox"/> SIREN HIGH <input type="checkbox"/>
STROBE	STROBE LOW <input checked="" type="checkbox"/> STROBE HIGH <input type="checkbox"/>

Triggering output normally connected to +12V, Siren/Strobe will be activated when connection with +12V is discontinued.

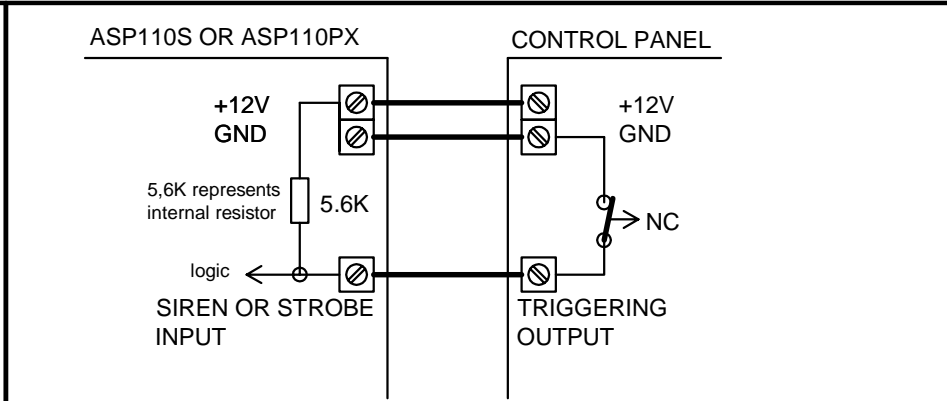

JUMPER SETTINGS	
SIREN	SIREN LOW <input type="checkbox"/> SIREN HIGH <input checked="" type="checkbox"/>
STROBE	STROBE LOW <input type="checkbox"/> STROBE HIGH <input checked="" type="checkbox"/>

Triggering output normally connected to GND, Siren/Strobe will be activated when connection with GND is discontinued.

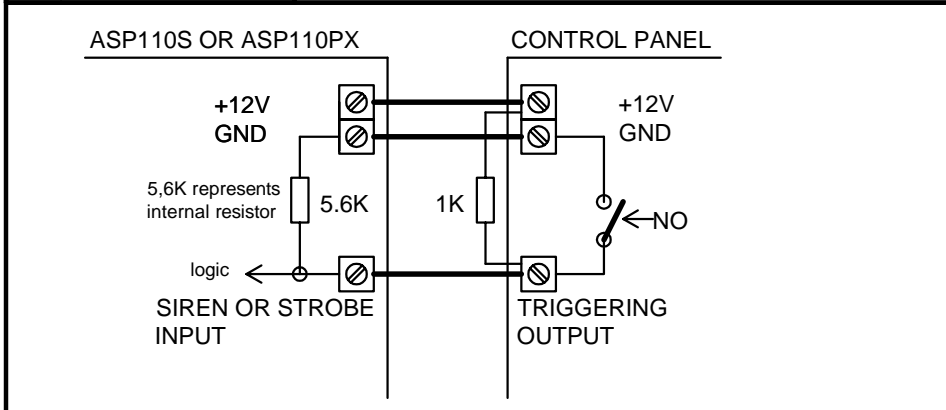

JUMPER SETTINGS	
SIREN	SIREN LOW <input checked="" type="checkbox"/> SIREN HIGH <input type="checkbox"/>
STROBE	STROBE LOW <input checked="" type="checkbox"/> STROBE HIGH <input type="checkbox"/>

Note:
The 1K resistor should be located at Control Panel connection terminals.

Triggering output normally remains in high resistance state, Siren/Strobe will be activated after connection with GND.

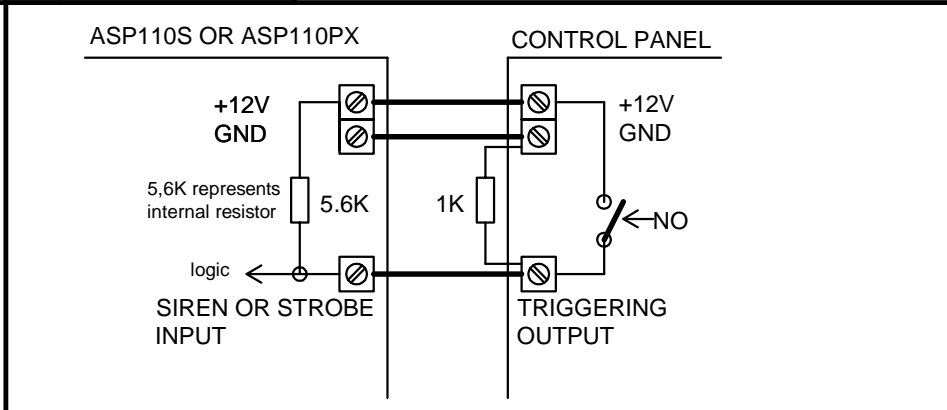

JUMPER SETTINGS	
SIREN	SIREN LOW <input type="checkbox"/> SIREN HIGH <input checked="" type="checkbox"/>
STROBE	STROBE LOW <input type="checkbox"/> STROBE HIGH <input checked="" type="checkbox"/>

Note:
The 1K resistor should be located at Control Panel connection terminals.

Triggering output normally remains in high resistance state, Siren/Strobe will be activated after connection with +12V.

Outdoor siren with alarm light ASP110 ver 1.3



		Triggering method selection		Sound modulation	
		STROBE-HIGH <input type="checkbox"/> STROBE-LOW <input type="checkbox"/>	Input normally shorted with supply minus	RAMP <input type="checkbox"/> SQR <input type="checkbox"/> UP <input type="checkbox"/> DOWN <input type="checkbox"/>	
		STROBE-HIGH <input type="checkbox"/> STROBE-LOW <input type="checkbox"/>	Input normally shorted with supply plus	DOWN <input type="checkbox"/> SQR <input type="checkbox"/> UP <input type="checkbox"/> RAMP <input type="checkbox"/>	
		SIREN-LOW <input type="checkbox"/> SIREN-HIGH <input type="checkbox"/>	Input normally shorted with supply plus	DOWN <input type="checkbox"/> SQR <input type="checkbox"/> UP <input type="checkbox"/> RAMP <input type="checkbox"/>	
		SIREN-LOW <input type="checkbox"/> SIREN-HIGH <input type="checkbox"/>	Input normally shorted with supply minus	DOWN <input type="checkbox"/> SQR <input type="checkbox"/> UP <input type="checkbox"/> RAMP <input type="checkbox"/>	
		SIREN-HIGH <input type="checkbox"/> SIREN-LOW <input type="checkbox"/>	Input normally not connected (left unconnected). Triggering will occur when supply plus or supply minus will be applied to input terminal.	DOWN <input type="checkbox"/> SQR <input type="checkbox"/> UP <input type="checkbox"/> RAMP <input type="checkbox"/>	
Siren signalization time (TIMER)		Siren auto-triggering by TAMPER		DOWN <input type="checkbox"/> SQR <input type="checkbox"/> UP <input type="checkbox"/> RAMP <input type="checkbox"/>	
<input type="checkbox"/> ON/OFF Short Middle	No limits	<input type="checkbox"/> ON/OFF Short Middle	Limited to 10 minutes	<input type="checkbox"/> AUTO TRIG. ON/OFF	Disabled
<input type="checkbox"/> ON/OFF Short Middle	Limited to 5 minutes	<input type="checkbox"/> ON/OFF Short Middle	Limited to 15 minutes	<input type="checkbox"/> AUTO TRIG. ON/OFF	Enabled

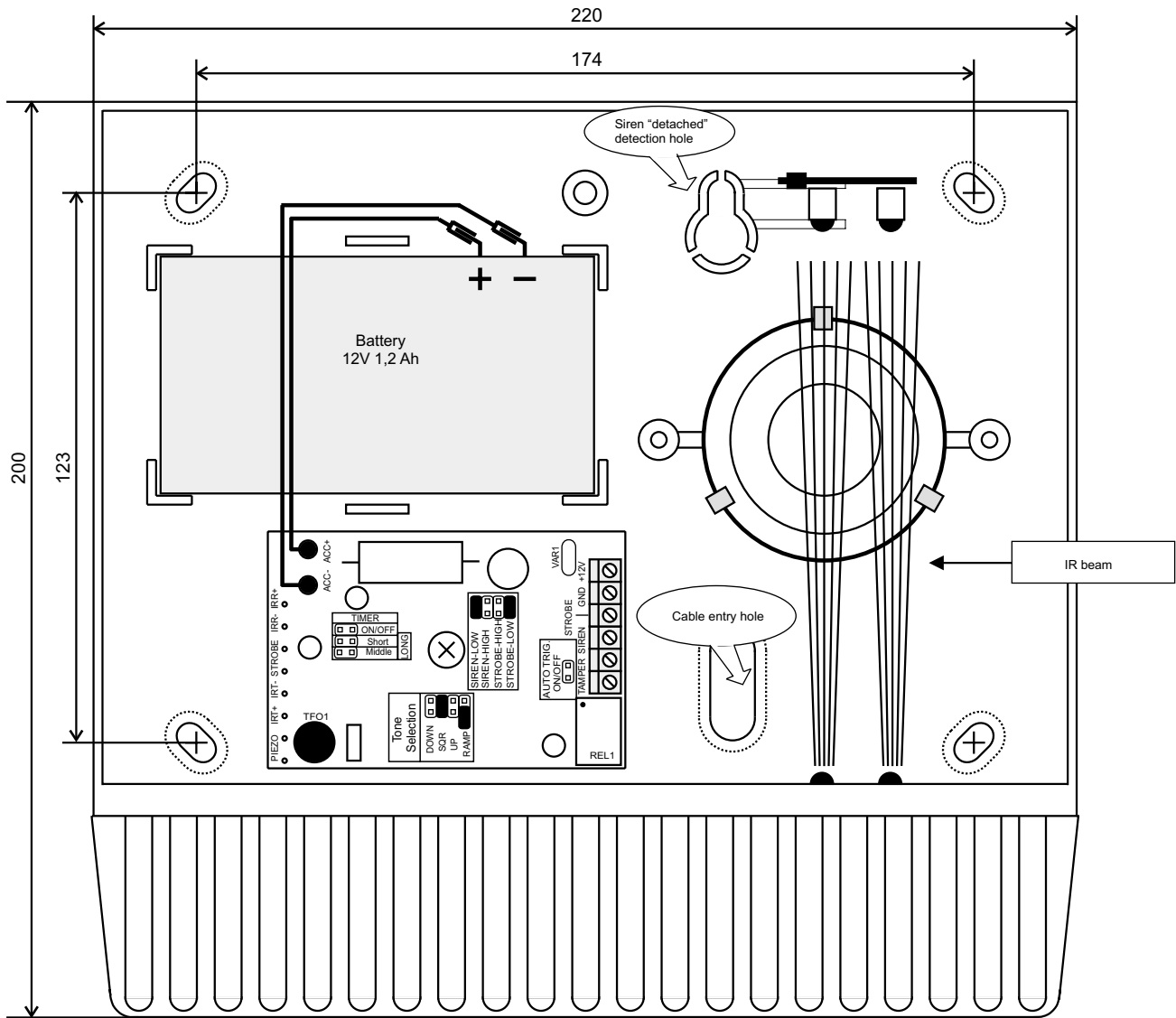

Settings options and internal view of ASP110