

# Roger Access Control System

## CEB12 Contactless Exit Button

### Installation Manual

Hardware version: v1.0  
Firmware version: 1.0.0.4 and newer

Document version: Rev. D

This document contains minimum information that is necessary for initial setup and installation of the device. The detailed description of configuration parameters and functionalities is specified in respective Operating Manual available at [www.roger.pl](http://www.roger.pl). This document is subject to the Terms of Use in the current version published on the website [www.roger.pl](http://www.roger.pl). The manufacturer reserves the right to make changes to the product without prior notice. © ROGER sp. z o. o. sp.k. All rights reserved.

## DESIGN AND APPLICATION

CEB12 is a contactless exit button which, after recognizing that the hand is approaching the front panel, temporarily switches on its electrical output. Basically, CEB12 has been designed to be used as a non-contact room exit button, and it can perform this function via a master device (e.g. access controller, intercom) or independently as standalone device. CEB12 can be powered independently from dedicated 12V DC/AC voltage source or in series with the energy receiver (electric strike), which it controls. The front panel of the device is made of natural glass and can be cleaned with disinfectants.

## CHARACTERISTICS

- Contactless exit button
- 12 VDC/AC power supply or from door strike circuit
- Adjustable detection distance (approx. 7-14 cm)
- Adjustable output activation time 1-5s
- Transistor output 12VDC/1A
- Overload and overvoltage protection
- LED backlight
- Tamper contact
- Indoor operation only
- Glass front panel
- Surface mounting enclosure with dimensions 85x85x22 mm
- CE mark

## INSTALLATION

### Configuration of detection distance:

CEB12 offers two levels of detections distance i.e. LOW and HIGH. The level is selected with jumper on DISTANCE contacts.

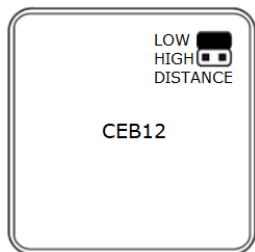

Fig. 1 LOW detection distance

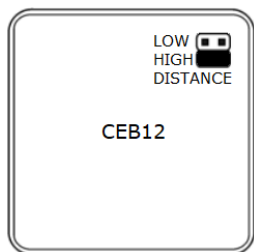

Fig. 2 HIGH detection distance

### Configuration of output activation time:

Output activation time for standalone operation is programmed with the RELEASE TIME button. In order to program the time, press the button and hold it down for the time for which the output is to be activated after detection of hand. During programming, the RED LED indicator located in the center of the front panel lights up. Time

parameter is recorded when the button is released or automatically after exceeding the maximum activation time (5s).

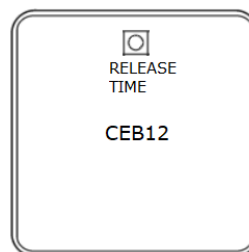

Fig. 3 Location of RELEASE TIME button

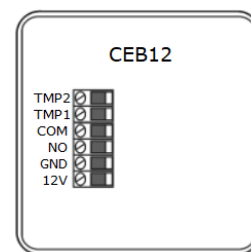

Fig. 4 Screw terminals

**Table 1. CEB12 screw terminals**

Name	Description
12V	12VDC power supply
GND	Ground
NO	Transistor output (NO)
COM	Transistor output (COM) internally connected with GND
TMP1	Tamper contact
TMP2	Tamper contact

## CONNECTION DIAGRAMS

### Connection to controller – independent power supply

This primary scenario of operation consists in connection of CEB12 to master device i.e. access controller which further controls door lock with its output. The example of connection is given in fig. 5 below.

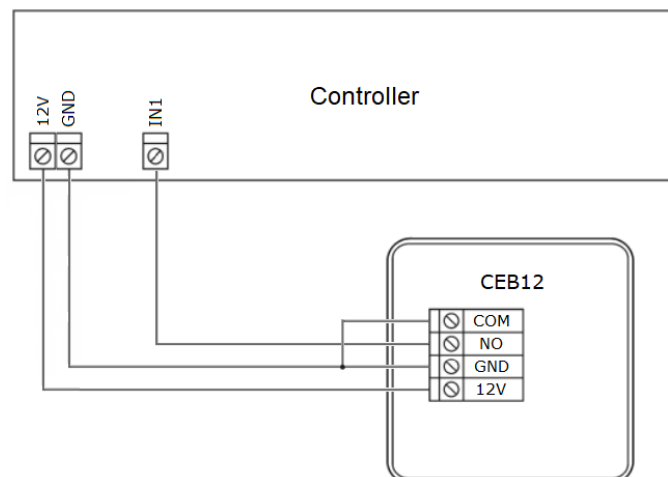

Fig. 5 Connection of CEB12 to controller – independent power supply

### Connection to controller – power supply in series with door lock

In this scenario of operation it is necessary to install resistor 220-470R 1W (not included) as in fig. 6. In such case the value of resistance affects CEB12 recovery time.

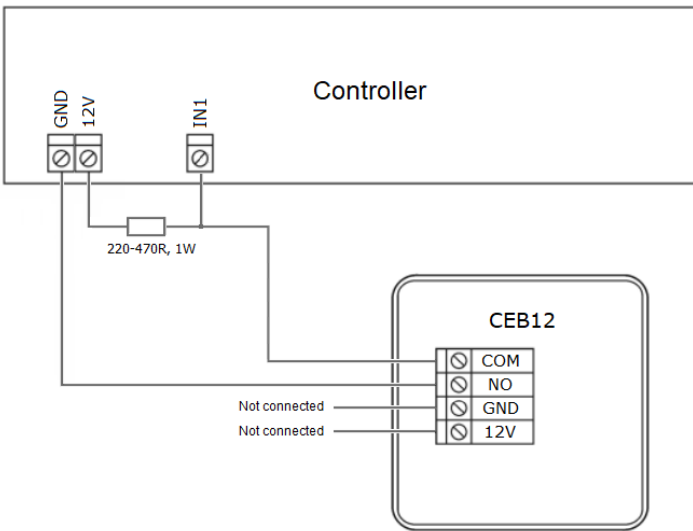

Fig. 6 Connection of CEB12 to controller – power supply in series with door lock

### Standalone operation – dedicated power supply

In this scenario of operation CEB12 controls door lock directly without master device (e.g. access controller) and it is supplied independently from power supply unit. Output activation time is configured with RELEASE TIME button.

Note: The maximal current of door lock cannot exceed 1A.

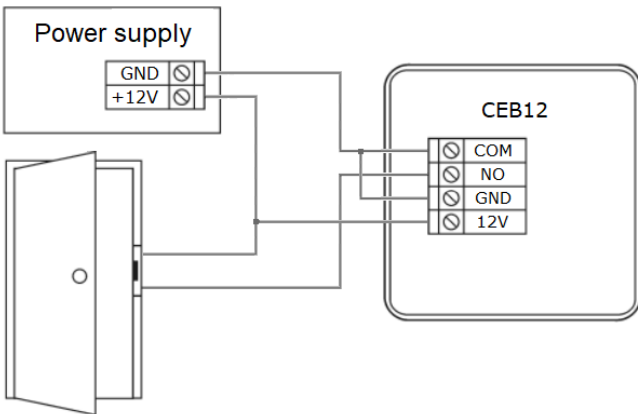

Fig. 7 Standalone operation – independent power supply

### Standalone operation – power supply in series with door lock

In this scenario of operation CEB12 controls door lock directly without master device (e.g. access controller) and it is supplied in series with door lock. Output activation time is programmed with the RELEASE TIME button.

Alternatively 12VAC transformer can be used instead of 12VDC PSU.

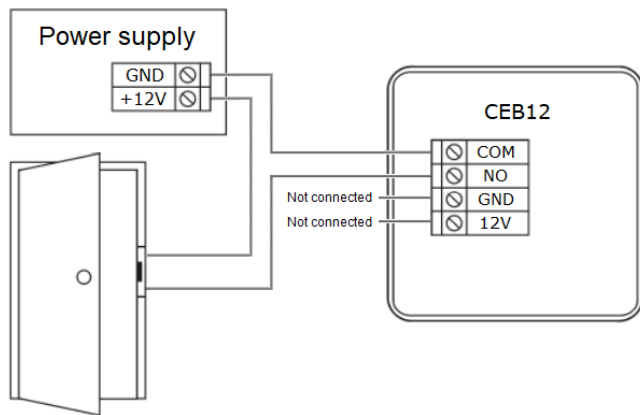

Fig. 8 Standalone operation – power supply in series with door lock

### Green backlight

On the front panel of CEB12 there is frame with green backlight. When the backlight is on then device is ready for operation and it awaits hand detection. The backlight switches off when its transistor output is activated. The backlight switches off also during programming with RELEASE TIME button.

### WALL MOUNTING

The device consists of front panel and base. Prior to CEB12 mounting both parts must be disassembled using included plastic key which must be inserted into each hall. Alternatively any flathead screwdriver can be used for disassembly.

Note: Each latch is released when plastic key is inserted into hole. Do not rotate key ending or lever any latch.

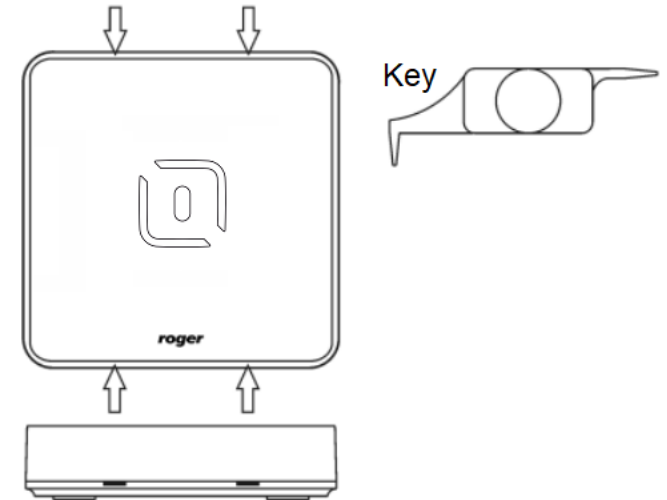

Fig. 9 Enclosure opening

### Installation guidelines

- The device should be mounted on a vertical structure (wall) away from sources of heat and moisture.
- Front panel should be attached in such way as the tamper detector would firmly press the back panel.
- All electrical connections should be done with disconnected power supply.
- If the device is installed in a place exposed to conductive dust (e.g. metal dust), protect the LOW/HIGH pins with insulating mass, e.g. silicone, after installation.
- Device can be cleaned by means of wet cloth and mild detergent without abrasive components. In particular do not clean with alcohols, solvents, petrol, disinfectants, acids, rust removers, etc. Damages resulting from improper maintenance and usage are not covered by manufacturer warranty.

### APPENDIX

Table 2. Specification	
Nominal supply voltage	12VDC or 12VDC/AC
Nominal supply current	~5 mA
Output	Transistor output 1A max load
Output activation time	Programmable in range of 1 - 5s and 1s resolution
Tamper protection	Isolated contact, NC type (normally closed when enclosure is assembled and attached), 24V/50mA
IK	IK06
IP	IP30
Environment	Indoor general conditions, temperature: -10°C to +50°C, relative humidity: 10 to 75% (no condensation)
Dimensions HWD	85x85x26 mm
Weight	~100g
Compliance	CE, RoHS
Manufacturer's warranty	36 months

<b>Table 3. Ordering information</b>	
CEB12	Contactless exit button; 12 VDC/AC power supply or from the electric door strike circuit; 12 VDC/1 A output; surface mounted housing; glass front panel; LED indicator; QUADRUS series design

<b>Table 4. Product history</b>		
Version	Date	Description
CEB12 v1.0	05/2022	The first commercial version of the product

	<p>This symbol placed on a product or packaging indicates that the product should not be disposed of with other wastes as this may have a negative impact on the environment and health. The user is obliged to deliver equipment to the designated collection points of electric and electronic waste. For detailed information on recycling, contact your local authorities, waste disposal company or point of purchase. Separate collection and recycling of this type of waste contributes to the protection of the natural resources and is safe to health and the environment. Weight of the equipment is specified in the document.</p>
--	---

**Contact:**  
**Roger Sp. z o. o. sp. k.**  
**82-400 Sztum**  
**Gościszewo 59**  
**Tel.: +48 55 272 0132**  
**Fax: +48 55 272 0133**  
**Tech. support: +48 55 267 0126**  
**E-mail: [support@roger.pl](mailto:support@roger.pl)**  
**Web: [www.roger.pl](http://www.roger.pl)**