

Roger Access Control System

Metal Enclosure ME-43

Operating Manual

Product version: v1.1

Firmware version: -

Document version: Rev. C

RoHS

CE



IP20

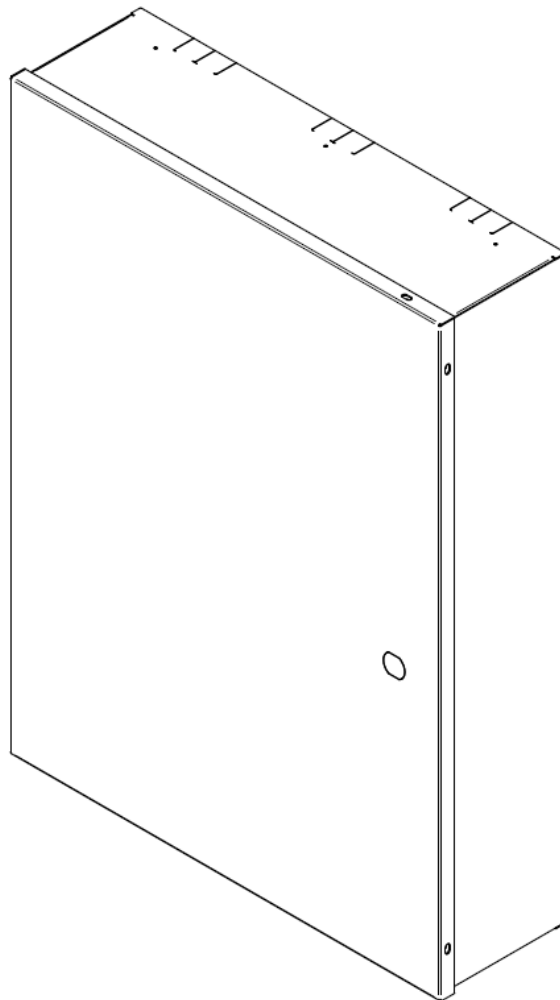

ATPP-447_ME-43v1.0.2.001

1. APPLICATION

The ME-43 housing is designed for RACS 5 modules powered by 13,8VDC and intended for mounting on a DIN rail. The enclosure is equipped with 2 DIN rail, tamper contact and fuse switch. Access to the internal space of the enclosure is protected by a door fixed by screws. Optionally, the door can be equipped with a key lock. The ME-43 is made of a metal sheet with an anthracite grey powder coating. Enclosure offers space for 17Ah battery. The enclosure was designed to be equipped with 13,8VDC/80W power supply module and power distribution module, however they are not installed in factory new ME-43 enclosure.

2. INSTALLATION

1. The enclosure shall be installed indoors ensuring nominal environmental conditions as stated in the *Specification* section of this document.
2. All installation and maintenance work inside the enclosure shall be done with the 230VAC power supply disconnected.
3. 230VAC power supply should be made with a three-wire cable including green-yellow PE wire.
4. Mains power supply cable shall be fed into the enclosure through hole B and fastened to G detail by a cable tie.
5. Connect the mains power cable as shown in the figure below (Fig. 1). L, N, and PE wires should be stripped of insulation for a length of 7 mm and mounted in the terminal in such a way that the insulated part of the wire is inside the terminal.

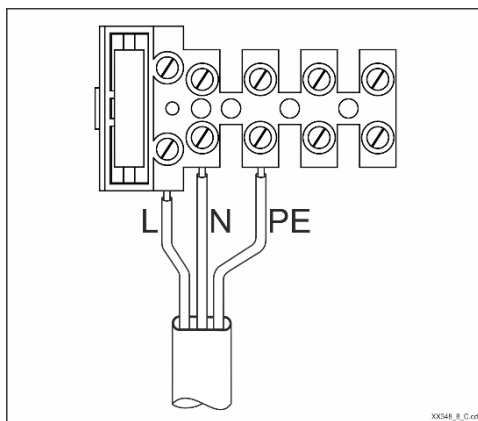

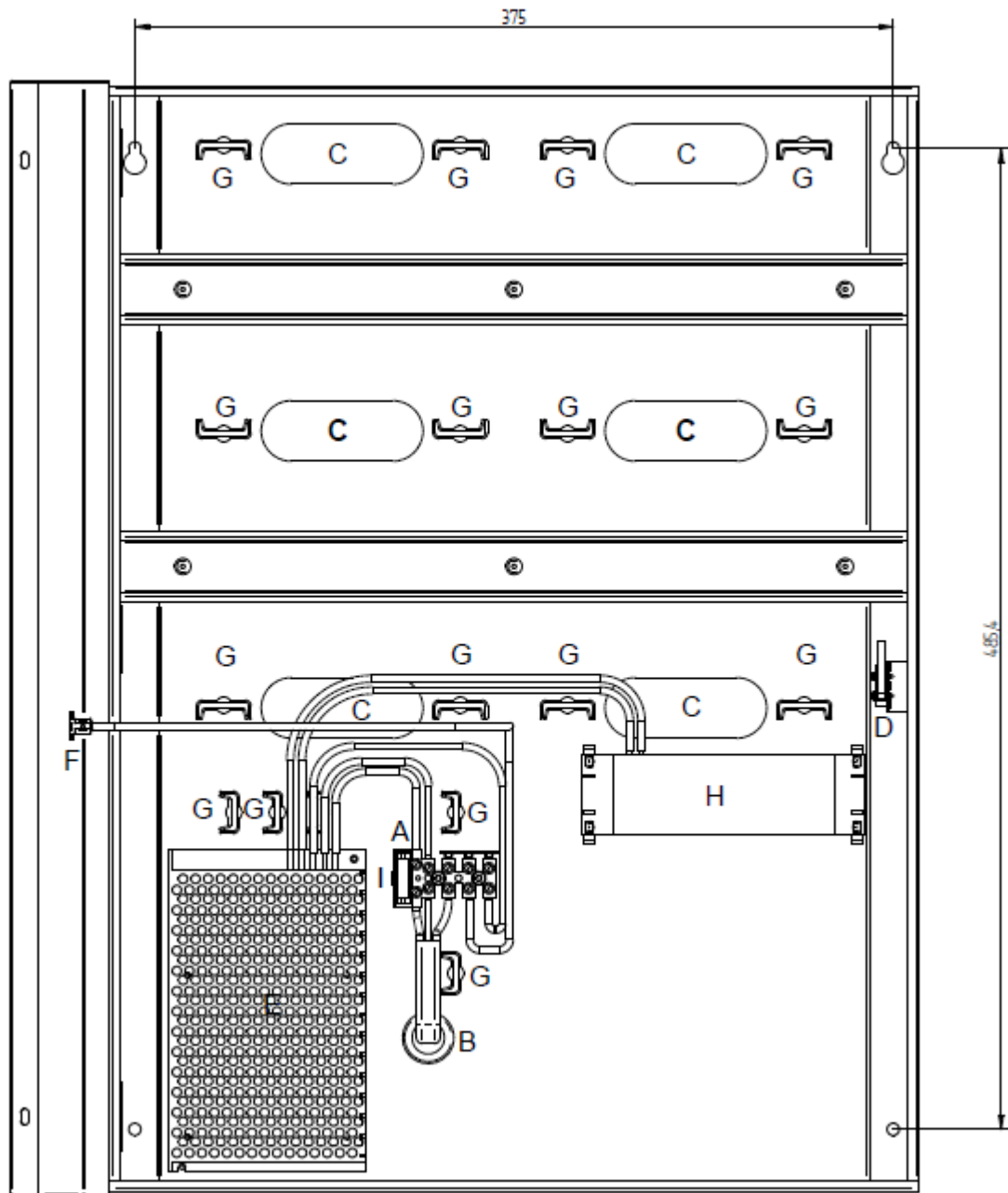

Fig. 1 Connection of the 230VAC mains power to the terminal block

6. Connection cables for installed devices must be fed into the enclosure through C holes.
7. In order to arrange the cables inside the enclosure, they should be fastened with cable ties to the G details. In order to use the G details, they must be levered first (ex. with a screwdriver) and bend to the vertical position (Fig. 3).
8. Configuration and adjustments of the modules installed in the enclosure should be done in accordance with their respective manuals.
9. To introduce cables into the enclosure from the upper or lower wall of the enclosure, form the cable holes as indicated in Fig. 4.
10. When electrical installation and configuration/test process is accomplished close door enclosure and fasten it with screws or lock (if installed).
11. Inform the end user how to disconnect the mains power supply from the device.

 Warnings 
The installation can be done by qualified person only who poses all necessary certificates concerning connection/maintenance of 230VAC and low voltage networks.
The network circuit supplying the device must be equipped with an installation switch with a nominal current of 6A. Before servicing the device, disconnect it from the 230VAC network.
System earthing must be performed carefully, properly and effectively. It is forbidden to use device without properly performed and fully operated protective earthing.
Follow the instructions included in the equipment to be installed in enclosure. Failure to do so may result in equipment damage, electric shock, fire, injury, or other consequences.



ATTP-476

Fig. 2 Internal view of ME-43 enclosure: A: Mains Supply Terminal Blocks with Fuse; B: Main Supply Entry Hole with Protective Sleeve; C: Low Voltage Connection Holes; D: Tamper Contact; E: Power Supply Module; F: Door PE Connector; G: Cable Tie Eyelets; H: Power Distribution Module

Note: Factory new ME-43 is not equipped neither with power supply module nor power distribution module .

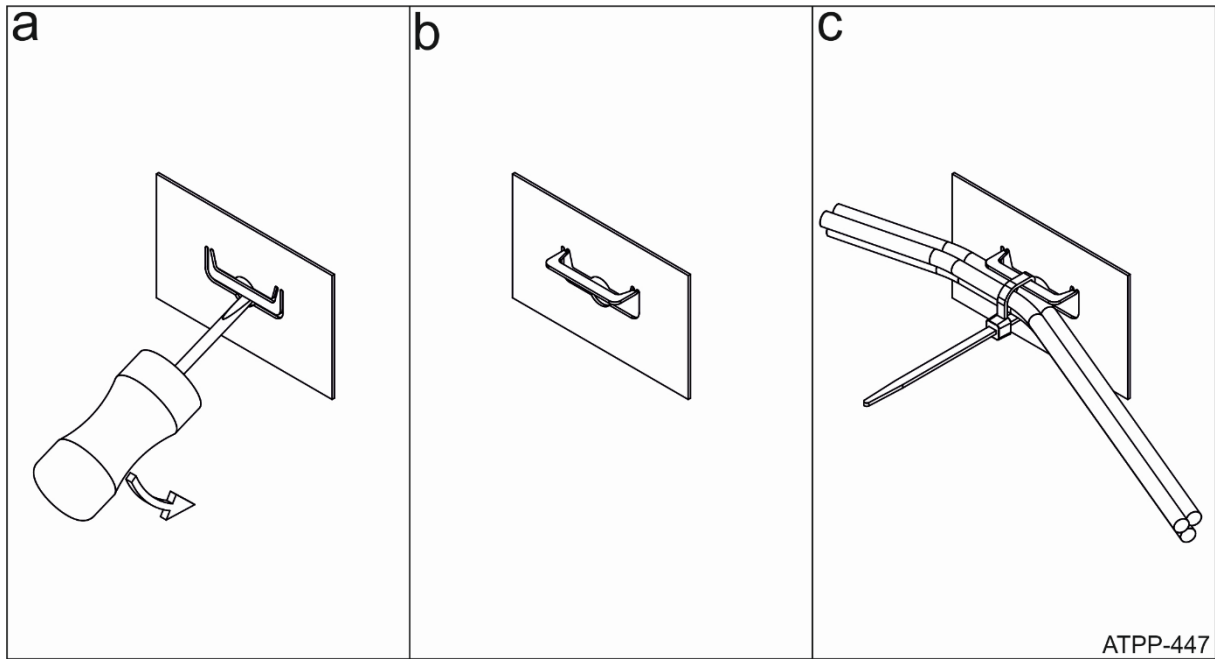

Fig. 3 Cable fixing method

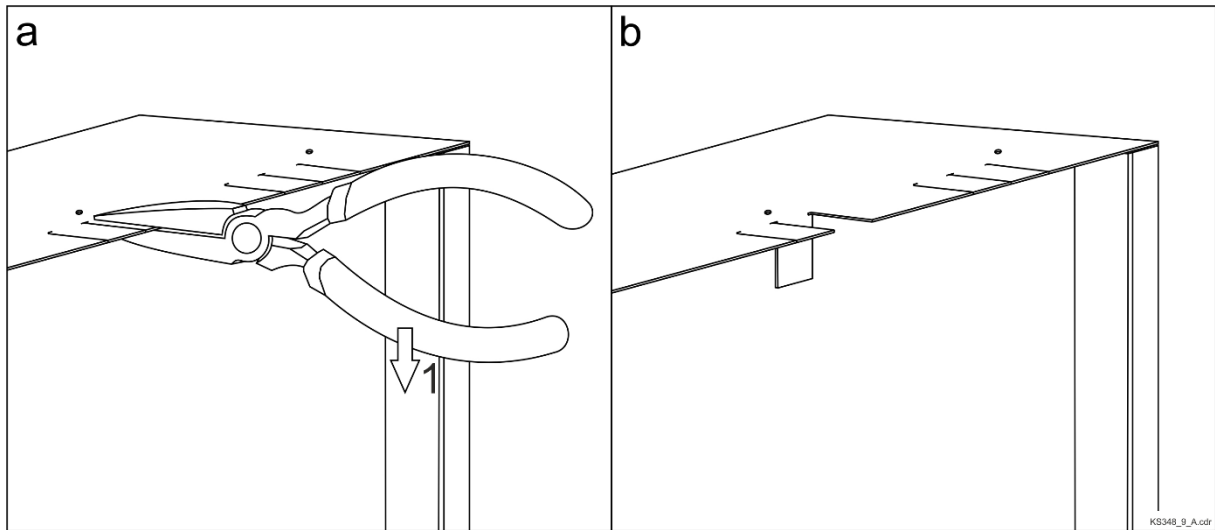

Fig. 4 Forming a cable entry hole in the bottom or top wall of the enclosure

3. SPECIFICATION

Parameter	Value
Nominal Power Supply	230VAC
Nominal Power (*)	80W
Nominal Output Voltage (*)	13,8VDC
Nominal Output Current (*)	5A
Power Supply Module (*)	PSG2-12V5A (Pulsar)
Power Distribution Module	B5/AW (AWZ536 Pulsar)
Mains Supply Protection Fuse	5A/250VAC
Tamper Protection	Tamper contact NO/NC; 50mA/50VDC

DIN Rail	2 × 396mm
Material	Metal sheet 0,8mm; anti-corrosion protection with powder coating
Colour	Anthracite grey RAL 7016 MAT
Battery Space	185 x 170 x 100 mm
Battery Type	17 Ah SLA or AGM
Environmental Conditions	Indoor general conditions; relative humidity up to 90%; temperature from +5°C to +40°C
Ingress Protection	IP20
Internal Dimensions (H x W x D)	398 × 545 × 100 mm
External Dimensions (H x W x D)	405 x 552 x 121 mm
Weight	5,3 kg
Compliant	CE; RoHS

4. ORDERING INFORMATION

Product	Description
ME-43	Standard version of the product

5. PRODUCT HISTORY

Version	Date	Description
ME-43 v1.0	07/2023	The first commercial version of the product
ME-43 v1.1	07/2024	The second commercial version of the product

	<p>This symbol placed on a product or packaging indicates that the product should not be disposed of with other wastes as this may have a negative impact on the environment and human health. The user is obliged to deliver equipment to the designated collection points of electric and electronic waste. For detailed information on recycling, contact your local authorities, waste disposal company, or point of purchase. Separate collection and recycling of this type of waste contributes to the protection of the natural resources and is safe for human health and the environment. Weight of the equipment is specified in the document.</p>
---	---

Contact:

Roger Sp. z o. o. Sp. k.

82-400 Gościszewo 59

Tel.: +48 55 272 0132

Fax: +48 55 272 0133

Technical Support: +48 55 267 0126

E-mail: support@roger.pl

www.roger.pl