

Roger Access Control System

MCT12E Operating Manual

Product version: 1.1

Firmware version: 1.0.4 or newer

Document version: Rev.D



This document is subject to the Terms of Use in the current version published on the website www.roger.pl.

The manufacturer reserves the right to make changes to the product without prior notice. © ROGER sp. z o. o. sp.k. All rights reserved.

1. DESIGN AND APPLICATION

The MCT12E is a series of access terminals dedicated to RACS 5 system. Depending on their versions, devices enable identification of users by PINs and/or EM125kHz (UNIQUE) proximity cards.

MCT12 is connected to access controller through RS485 interface. Terminal can be installed in outdoor locations without any additional protection measures.

Version	MCT12E	MCT12E-BK	MCT12E-IO	MCT12E-BK-IO
Keypad	Yes	-	Yes	-
Inputs	-		3	3
Relay output	-		1	1
Transistor outputs	-		2	2

Characteristics

- RACS 5 system access terminal
- EM125kHz (UNIQUE) proximity cards
- 3 LEDs indicators
- Buzzer
- Silicone keypad with backlight*
- 2 function keys*
- 3 NO/NC inputs**
- 2 transistor outputs**
- 1 relay output**
- RS485 interface
- Tamper protection
- Outdoor environment
- Connection cable

** not in -BK versions

*** only -IO versions

Power supply

The terminal requires power supply voltage in range of 11-15VDC. It can be supplied from MCX2D/MCX4D expander of MC16-PAC-KIT, from MC16 access controller (e.g. TML output) or from dedicated power supply unit. The supply wire diameter must be selected in such way that the voltage drop between supply output and the device would be lower than 1V. The proper wire diameter is especially critical when device is located in long distance from the supply source. In such a case the use of dedicated power supply unit located close to the device should be considered. When separate power supply unit is used then its minus should be connected to controller's GND by means of signal wire with any diameter. It is recommended to use UTP cable for connection of device to controller. The table below shows maximal UTP cable lengths in relation to the number of wires used for power supply.

Number of UTP wire pairs for power supply	Maximal length of power supply cable
1	150m
2	300m
3	450m
4	600m

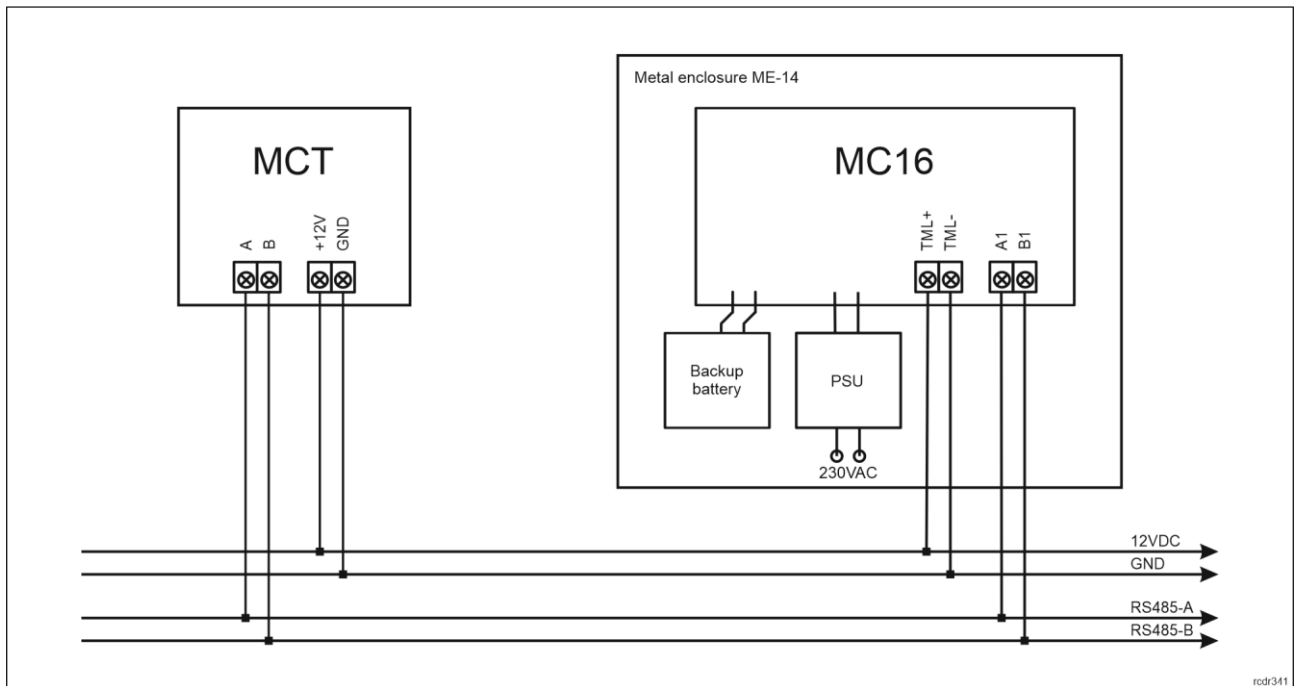

Fig. 1 MCT supply from MC16 access controller

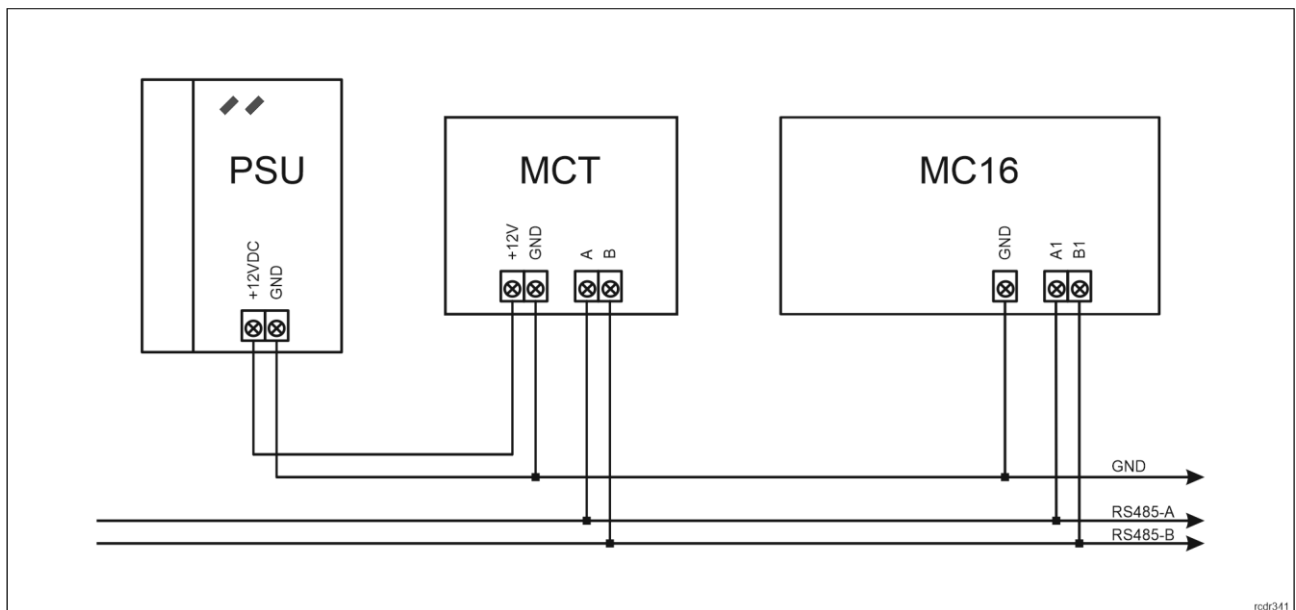

Fig. 2 MCT supply from dedicated power supply unit

RS485 bus

The communication method with MC16 access controller is provided with RS485 bus which can encompass up to 16 devices of RACS 5 system, each with unique address in range of 100-115. The bus topology can be freely arranged as star, tree or any combination of them except for loop. The matching resistors (terminators) connected at the ends of transmitting lines are not required. In most cases communication works with any cable type (standard telephone cable, shielded or unshielded twisted pair etc.) but the recommended cable is unshielded twisted pair (U/UTP cat.5). Shielded cables should be limited to installations subject to strong electromagnetic interferences. The RS485 communication standard used in the RACS 5 system guarantees proper communication in a distance of up to 1200 meters as well as high resistance to interferences.

Note: Do not use more than single pair in UTP cable for RS485 communication bus.

Keypad

Except for –BK versions, terminals are equipped with numeric keypad and backlight. The keypad can be used for user identification with PIN and for various keypad commands. By default, the key [#] is used for PIN confirming.



Function keys

Except for –BK versions, terminals are equipped with two function keys [F1] and [F2]. Various functions can be assigned to these keys within high level configuration (VISO) e.g. door bell, Set T&A Mode, Register Guard Tour Event, Set Automation Node On, etc. Within low level configuration (RogerVDM) of the terminal it is possible to configure if the terminal distinguishes short and long key pressings. Consequently, each type of key press can be assigned with a different function.

Numeric keypad includes [*] and [#] keys which can be configured as function keys.

LED indicators

Terminals are equipped with three LED indicators which are used to signal integral functions and they can be additionally programmed with other available functions within high level configuration (VISO).

Table 3. LED indicators			
Indicator	Symbol	Colour	Integral functions
LED STATUS		Red / green	Default colour of the indicator is red. If the terminal is assigned to Alarm Zone then the LED indicates zone arming (red) or disarming (green).
LED OPEN		Green	LED indicates access granting.
LED SYSTEM		Orange	LED indicates card reading and can signal other system functions including device malfunction.

Note: Synchronic pulsing of LED indicators signifies lost communication with MC16 controller.

Buzzer

Terminals are equipped with a buzzer which is used to signal integral functions and it can be additionally programmed with other available functions within high level configuration (VISO).

Inputs

Terminals in –IO version e.g. MCT12E-IO offer 3 general purpose inputs of NO/NC type. Input types are defined within low level configuration (RogerVDM). Input functions are assigned within high level configuration (VISO). Multiple functions can be assigned to the same input at the same time.

Tamper detector

Built-in tamper (sabotage) detector enables detection of unauthorized opening of the device's enclosure as well as detachment of the enclosure from the wall. The detector is internally connected to the terminal's TMP wires. It does not require low level configuration (RogerVDM) but it is necessary to connect it to the controller with wires as in the example in fig. 3. It is also essential to mount the front panel in such a way as the tamper detector (fig. 4) would firmly press the back panel.

The input of the controller for connection of the tamper loop requires low level configuration in regard of NC type (RogerVDM) and high level configuration consisting in assignment of the function [133] *Tamper Toggle* on the level of a *Main Board* of a controller in VISO software navigation tree.

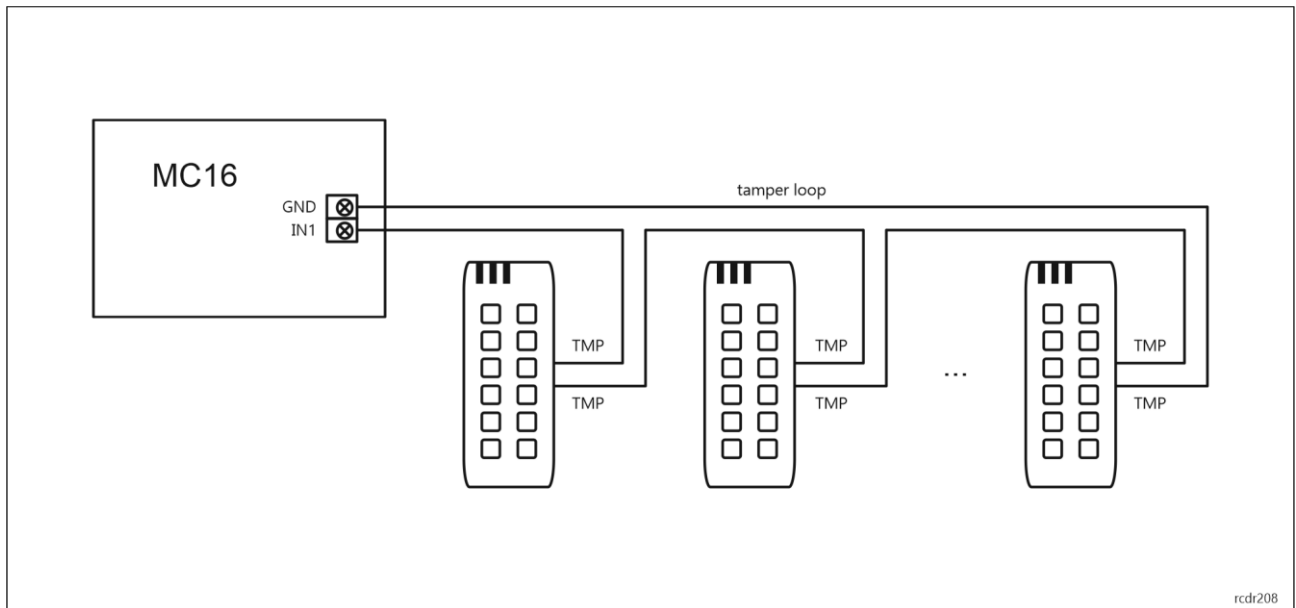

Fig. 3 Tamper loop example

Outputs

Terminals in -IO version e.g. MCT12E-IO offer 2 transistor open collector type outputs (15V/1A rated) and 1 relay output with NO/NC contacts (30V/1.5A DC/AC rated). Electric parameters such as polarity are configured within low level configuration (RogerVDM). Function are assigned to outputs within high level configuration (VISO). Multiple functions with different priorities can be assigned to the same output at the same time.

Identification

Depending on the version, following user identification methods are offered by terminals:

- EM125kHz (UNIQUE) proximity cards
- PINs

EM125kHz cards

EM125kHz proximity cards are widely used in office buildings. If it is necessary to ensure higher level of security then MIFARE card readers e.g. MCT12M are recommended.

The technical characteristics of the device are guaranteed for RFID cards supplied by Roger. Cards from other sources may be used, but they are not covered by the manufactures warranty. Before deciding to use specific Roger products with third-party contactless cards, it is recommended to conduct tests that will confirm satisfactory operation with the specific Roger device and software in which it operates.

PINs

Except for -BK versions, terminals accept variable length PINs (by default 4-8 digits concluded with [#] key).

2. INSTALLATION

Name	Wire colour (-IO version)	Wire colour	Description
12V	Red	Red	12VDC power supply
GND	Black	Blue	Ground
IN1	Pink		IN1 input line
IN2	Blue		IN2 input line

IN3	White-yellow		IN3 input line
RS485 A	Brown	Brown	RS485 bus, line A
RS485 B	Green-white	White	RS485 bus, line B
CLK	White	Green	CLK line
DTA	Green	Yellow	DTA line
TMP	Yellow	Pink	Tamper contact
TMP	Grey	Grey	Tamper contact
IO1	Yellow-brown		IO1 output line
IO2	Green-brown		IO2 output line
REL1-NC	Grey-pink		REL1 relay normally closed contact
REL1-COM	Red-blue		REL1 relay common contact
REL1-NO	Violet		REL1 relay normally opened contact

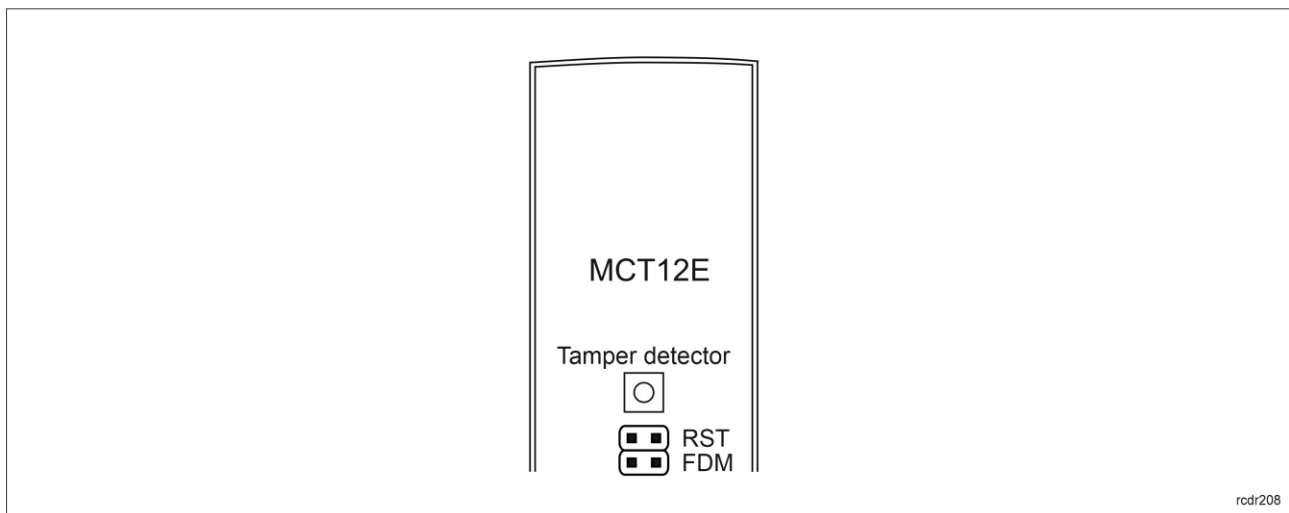

Fig. 4 Programming jumpers

MCT12 terminal

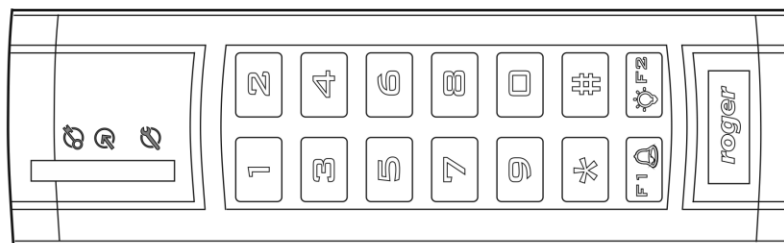
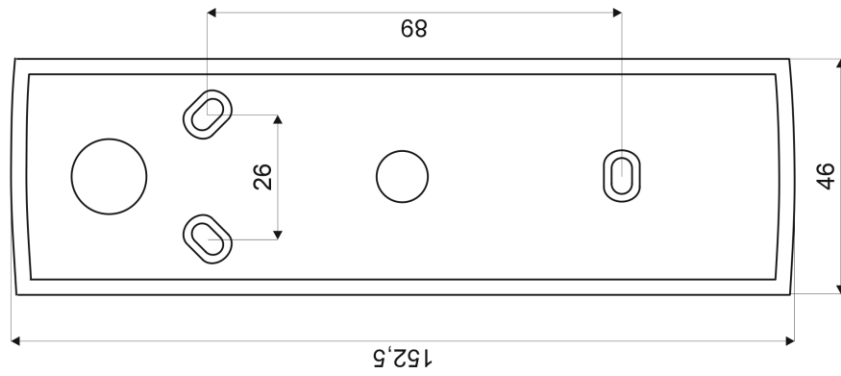
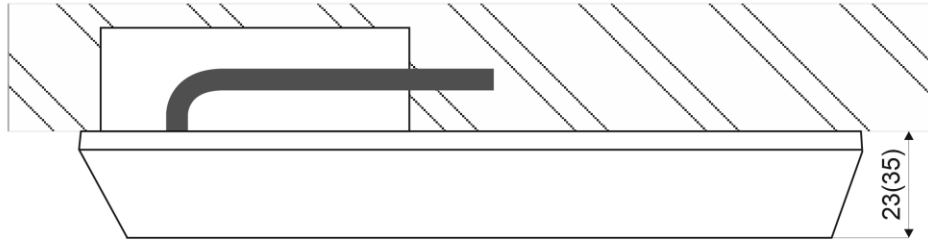

Fig. 5 MCT12E installation

Note: New device is assembled with standard back panel with 23mm thickness but additional back panel with 35mm thickness is included. Such panel can be used if more space for connection cable is needed and it may also improve card reading distance if the terminal is mounted on metal surface.

Installation guidelines

- The terminal should be mounted on a vertical structure (wall) away from sources of heat and moisture.
- Front panel should be attached in such way as the tamper detector (fig. 4) would firmly press the back panel.
- All electrical connections should be done with disconnected power supply.
- If the terminal and controller are not supplied from the same PSU then GND terminals of both devices must be connected with any wire.
- Device can be cleaned by means of wet cloth and mild detergent without abrasive components. In particular do not clean with alcohols, solvents, petrol, disinfectants, acids, rust removers, etc. Damages resulting from improper maintenance and usage are not covered by manufacturer warranty.
- The IP65 rating is guaranteed if the bottom of the housing is tightly adhered to the surface on which the device is installed. It is the installer's responsibility to seal the space between the bottom of the housing and the surface on which the device is mounted.
- The electronic module inside the housing is sensitive to electrostatic discharge. Before performing any work on the module, any electrical charge accumulated on the person performing work inside the device must be removed. This can be accomplished, for example, by touching a grounded metal object with a bare hand.

3. OPERATION SCENARIOS

The terminal when connected to MC16 access controller can be at the same time used for access control and Time&Attendance. The example of connection diagram for such scenario is shown in fig. 6 where inputs and outputs from MC16 board are used and in fig. 7 where inputs and outputs from -IO version terminal are used. The terminal can also operate with MC16 controller using MCX2D/MCX4D expanders as in case of M16-PAC-KIT series. Various scenarios of operation with MC16 controllers are presented in AN002 application note.

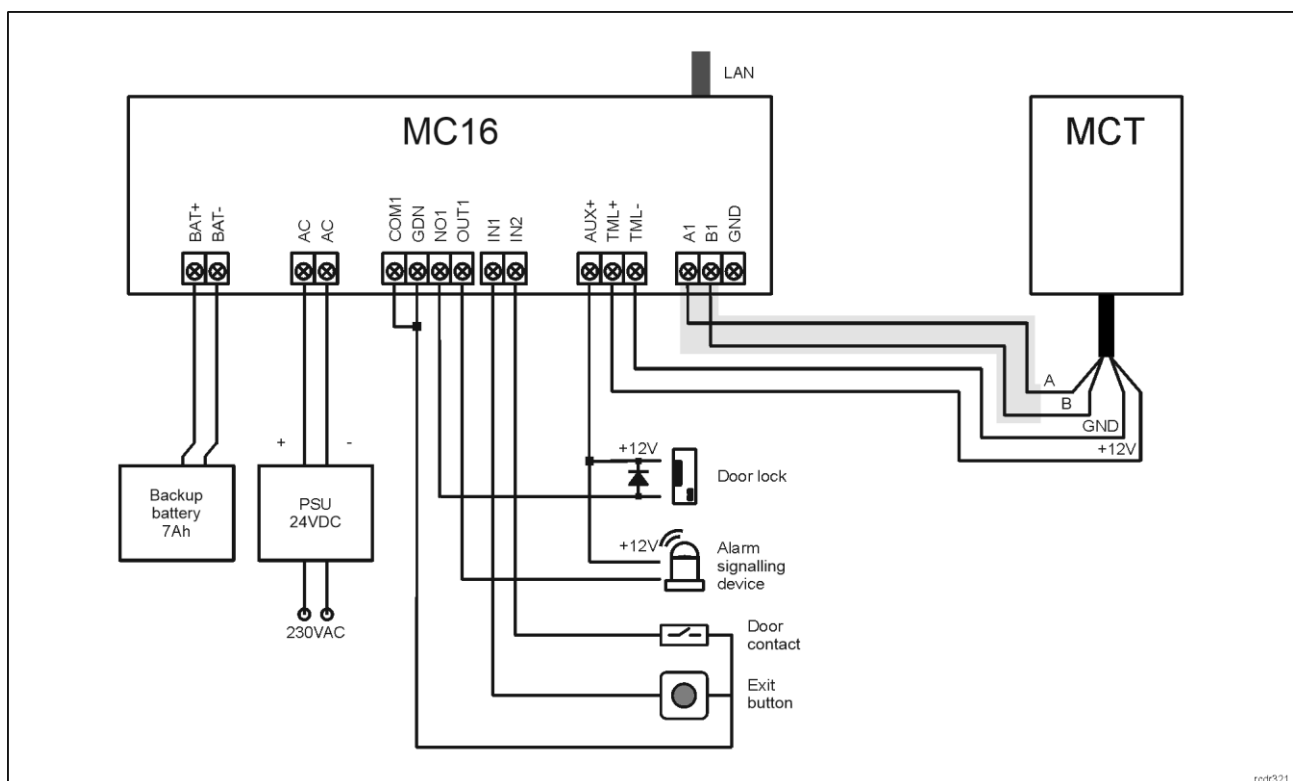

Fig. 6 Typical connection diagram for the terminal and MC16 access controller

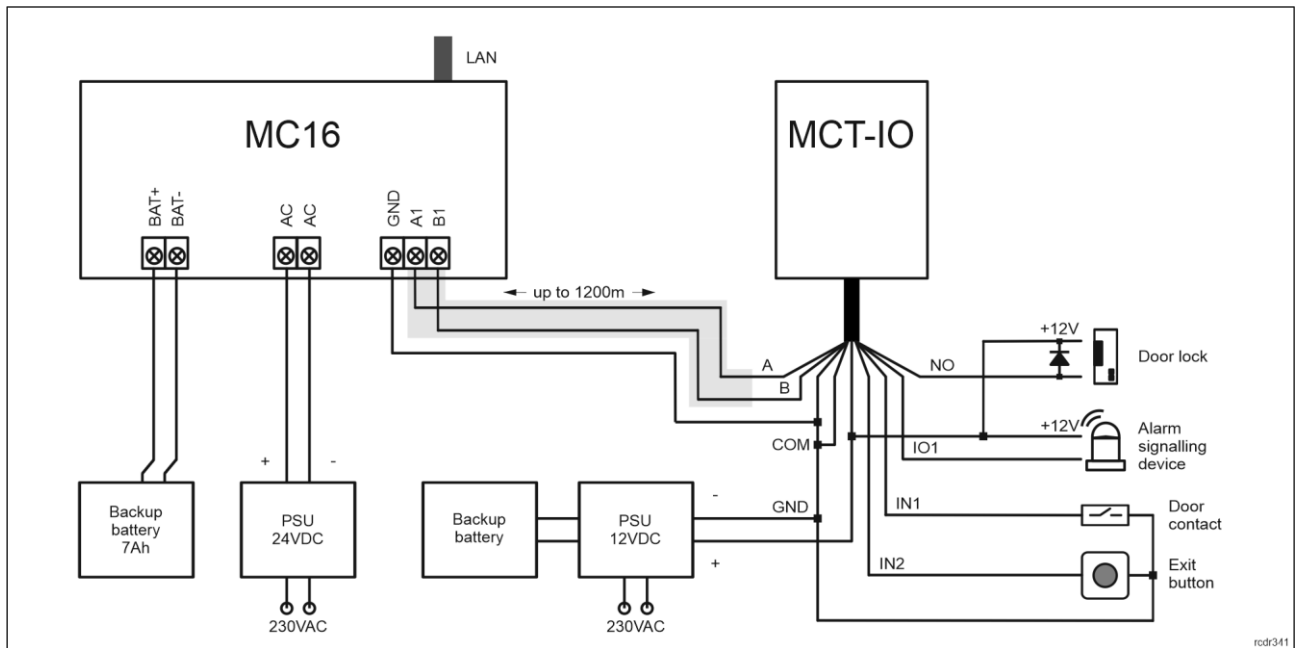

Fig. 7 Typical connection diagram for the -IO version terminal and MC16 access controller

4. CONFIGURATION

Low level configuration (RogerVDM)

The purpose of low level configuration is to prepare device for operation in RACS 5 system.

Programming procedure with RogerVDM software:

1. Connect the reader to RUD-1 interface (fig. 8) and connect the RUD-1 to computer's USB port.
2. Start RogerVDM program, select *MCT* device, firmware version, *RS485* communication channel and serial port with RUD-1 interface.
3. Click *Connect*, the program will establish connection and will automatically display *Configuration* tab.
4. Enter unoccupied RS485 address in range of 100-115 and other settings according to requirements of specific installation.
5. Click *Send to Device* to update the configuration of reader.
6. Optionally make a backup by clicking *Send to File...* and saving settings to file on disk.
7. In the top menu select *Device->Disconnect*.
8. Disconnect reader from RUD-1 interface.

Note: Do not read any cards nor press keypad when reader is configured with RogerVDM.

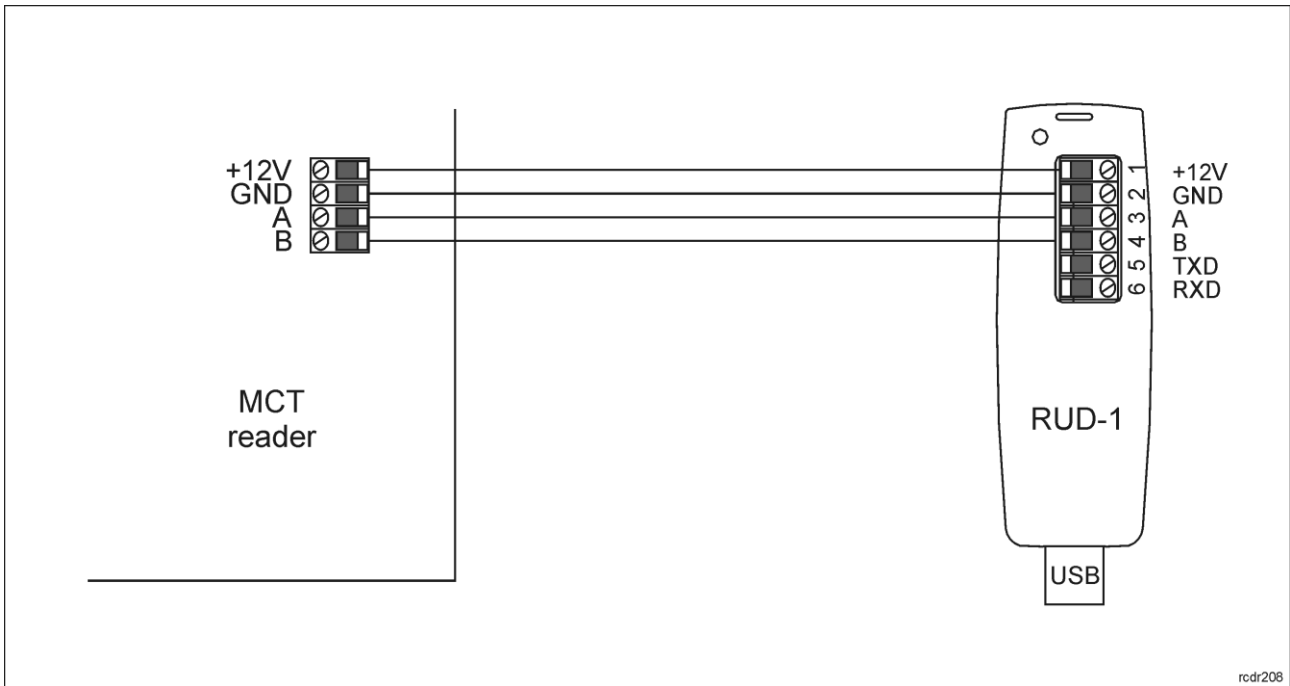

Fig. 8 Connection to RUD-1 interface

Table 5. List of low level parameters	
Communication settings	
RS485 address	Parameter defines device address on RS485 bus. Range: 100-115. Default value: 100.
RS485 communication timeout [s]	Parameter defines delay after which device will signal lost communication with controller. When set to 0 then signaling is disabled. Range: 0-64s. Default value: 20s.
General settings	
Card reading disabled	Parameter enables blocking of card reading in selected technology. The parameter is dedicated to terminals which support more than one card reading technology.
Card reading synchronisation input	Parameter enables selection of reader input which will be used for synchronisation of magnetic field with another reader in vicinity to prevent interferences between both readers. Selected input must be connected to synchronisation output of another reader. When set to 0 then synchronisation is disabled. Typical numbering is 1 = IN1, 2 = IN2 and 3 = IN3. Range: 0-3. Default value: 0.
Card reading synchronisation output	Parameter enables selection of reader output which will be used for synchronisation of magnetic field with another reader in vicinity to prevent interferences between both readers. Selected output must be connected to synchronisation input of another reader. When set to 0 then synchronisation is disabled. Typical numbering is 1 = REL1, 2 = OUT1 and 3 = OUT2. Range: 0-3. Default value: 0.
Single key press	Parameter enables separate transmission of each pressed key to controller. Range: [0]: No, [1]: Yes. Default value: [1]: Yes.
Min. length of PIN	Parameter defines the minimal number of digits for PIN entered with keypad. If the number of entered digits is lower than this parameter then it cannot be sent to controller when concluded with [#] key. When set to 0 then PINs are disabled. Range: 4-8. Default value: 4.
Max. length of PIN	Parameter defines the maximal number of digits for PIN entered with keypad. If the number of entered digits reaches this parameter

	then PIN is automatically sent to controller and [#] key pressing is not necessary. When set to 0 then automatic PIN transmission is disabled. Range: 0-8. Default value: 8.
[*] key clears PIN buffer	Parameter defines if already entered digits of PIN can be deleted with [*] key. Range: [0]: No, [1]: Yes. Default value: [1]: Yes.
Time between keys in PIN [s]	Parameter defines max. time between two consecutive key pressings. Range: 0-64. Default value: 10.
PIN followed by [#] key	Parameter enables use of PINs with variable length. In such scenario PIN is concluded with [#] key. Range: [0]: No, [1]: Yes. Default value: [1]: Yes.
Long key press time [s]	Parameter defines long press time for such key types as [*], [#] and [F1] - [F4]. When set to 0 then long press is disabled. Range: 0-64. Default value: 2.
Key press options	Parameter defines key press type for [*], [#] and [F1] - [F4] keys. Range: [1]: Short press only, [2]: Long press only, [3]: Short and long press. Default value: [1]: Short press only.
Backlight level [%]	Parameter defines backlight level. When set to 0 then backlight is disabled. Range: 0-100. Default value: 100.
Input types	
IN1, IN2, IN3	Parameter defines the type of input line. Range: [1]: NO, [2]: NC. Default value: [1]: NO.
Input comments	
IN1, IN2, IN3	Parameter defines any text or comment which corresponds to the object. It is later displayed in VISO program.
Output polarity	
REL1, IO1, IO2	Parameter defines polarity of output. Normal polarity means that the output by default is switched off while Reversed polarity means that the output by default is switched on. Range: [0]: Normal polarity, [1]: Reversed polarity. Default value: [0]: Normal polarity.
Output comments	
REL1, IO1, IO2	Parameter defines any text or comment which corresponds to the object. It is later displayed in VISO program.
Object comments	
DEV	Parameter defines any text or comment which corresponds to the device. It is later displayed in VISO program.
Internal Terminal ID1	
Terminal enabled	Parameter enables to activate/deactivate card reader.
Keypad enabled	Parameter enables to activate/deactivate keypad.
AF type	Parameter defines authentication factor returned by terminal ID1.
AF class	Parameter defines authentication factor class returned by terminal ID1.
KBD, CDI, BUZZER, LED OPEN, LED STATUS comment	Parameter defines any text or comment which corresponds to the object. It is later displayed in VISO program.
RACS CLK/DTA Terminal ID0	
Settings in this area do not refer to standard MCT12E readers.	

Note: Table 5 includes summary of parameters for all versions of MCT12E terminal. For instance keypad settings are not available for -BK version of terminals i.e. terminals without keypad.

Manual addressing

Manual addressing can be done within memory reset procedure.

Memory reset procedure

Memory reset procedure enables configuration of RS485 address and resets all other settings to factory default ones.

Memory reset procedure:

1. Remove all connections from A and B lines.
2. Connect CLK and DTA lines.
3. Restart the reader (switch power supply off and on or short RST contacts for a moment).
4. When red LED STATUS, green LED OPEN and orange LED SYSTEM are on then disconnect CLK and DTA lines.
5. When orange LED SYSTEM is on then enter 3 digits of RS485 address in range of 100-115 with reader keypad or with any EM125kHz proximity card.
6. When the third digit is defined then the reader will restart with the new address.

Readers without keypad can be addressed with multiple card readings where the N number of readings emulates digit of the address. Three series of readings with any EM125kHz proximity card are necessary to set the address. After each series wait for two beeps and proceed with the next digit. Zero digit is emulated with 10 readings.

Example:

Programming of ID=101 address with card readings:

1. Read card 1 time and wait for two beeps.
2. Read card 10 times and wait for two beeps.
3. Read card 1 time and wait for two beeps.
4. Wait till reader is restarted with the new address and other default settings.

High level configuration (VISO)

The purpose of high level configuration is to define logical functioning of the terminal which communicates with the MC16 access controller and it depends on applied scenario of operation. The example of access control system configuration is given in AN006 application note which is available at www.roger.pl.

5. FIRMWARE UPDATE

The update requires connection of reader to computer with RUD-1 interface (fig. 8) and starting RogerISP software. The latest firmware file is available at www.roger.pl.

Firmware update procedure:

1. Connect the reader to RUD-1 interface (fig. 8) and connect the RUD-1 to computer's USB port.
2. Place jumper on FDM contacts (fig. 4).
3. Restart the reader (switch power supply off and on or short RST contacts for a moment).
4. Start RogerISP program.
5. Select serial port with RUD-1 interface and *USB-RS485 Converter* option.
6. Specify path to firmware file (*.hex).
7. Click *Program* and proceed according to displayed messages.
8. Remove jumper from FDM contacts and restart the reader.

6. SPECIFICATION

Table 6. Specification	
Nominal supply voltage	12VDC
Nominal current consumption	MCT12E/MCT12E-IO: ~50 mA MCT12E-BK/MCT12E-BK-IO: ~40 mA
Inputs	Three inputs (IN1..IN3) electrically connected internally to +12V through a 5.6 kΩ resistor. NO and NC lines approx. 3.5V triggering level
Relay output	Relay output (REL1) with single NO/NC contact, 30V/1.5A DC/AC max. load

Transistor outputs	Two (IO1, IO2) open collector outputs, 15VDC/1A max. load
Tamper protection	Isolated 50mA/24V contacts, shorted when enclosure is closed
Identification methods	EM 125 kHz UNIQUE according to EM4100/4102
Reading range	Up to 7 cm
RS485 distances	Up to 1200 m between controller and terminal
IK	IK07
IP	IP65
Operating environment	Outdoor general conditions, temperature: -25°C to +60°C, relative humidity: 10 to 75% (no condensation)
Dimensions H x W x D	152,5 x 46 x 23(35) mm
Weight	~150g
Compliance	CE, RoHS
Manufacturer's warranty	36 months

7. ORDERING INFORMATION

Table 7. Ordering information	
MCT12E-BK	EM 125 kHz access terminal
MCT12E-BK-IO	EM 125 kHz access terminal; on-board I/Os
MCT12E	EM 125 kHz access terminal with keypad
MCT12E-IO	EM 125 kHz access terminal with keypad; on-board I/Os
RUD-1	Portable USB-RS485 communication interface dedicated to ROGER access control devices

8. PRODUCT HISTORY

Table 8. Product history		
Version	Date	Description
MCT12E v1.0	01/2015	The first commercial version of product
MCT12E v1.1	12/2015	Minor modifications of power supply and RS485 circuits



This symbol placed on a product or packaging indicates that the product should not be disposed of with other wastes as this may have a negative impact on the environment and health. The user is obliged to deliver equipment to the designated collection points of electric and electronic waste. For detailed information on recycling, contact your local authorities, waste disposal company or point of purchase. Separate collection and recycling of this type of waste contributes to the protection of the natural resources and is safe to health and the environment. Weight of the equipment is specified in the document.

Contact:
Roger sp. z o.o. sp.k.
82-400 Sztum
Gościszewo 59
Tel.: +48 55 272 0132
Fax: +48 55 272 0133
Tech. support: +48 55 267 0126
E-mail: support@roger.pl
Web: www.roger.pl