

*Roger Access Control System*

## MCT62E Reader

### Operating Manual

*Hardware version: v1.0*

*Firmware version: 1.1.18 or newer*

Document version: Rev. G



*This document is subject to the Terms of Use in the current version published on the website [www.roger.pl](http://www.roger.pl). The manufacturer reserves the right to make changes to the product without prior notice. © ROGER sp. z o. o. sp.k. All rights reserved.*

## 1. DESIGN AND APPLICATION

The MCT62E is an access terminal dedicated to RACS 5 system. The device enables identification of users by EM125kHz (UNIQUE) proximity cards.

MCT62EM is connected to access controller through RS485 interface. Terminal can be installed in outdoor locations without any additional protection measures.

### Characteristics

- RACS 5 system access terminal
- EM125kHz (UNIQUE) proximity cards
- 3 LEDs indicators
- Buzzer
- RS485 interface
- Tamper protection
- Outdoor environment
- Screw terminals

### Power supply

The terminal requires power supply voltage in range of 11-15VDC. It can be supplied from MCX2D/MCX4D expander of MC16-PAC-KIT, from MC16 access controller (e.g. TML output) or from dedicated power supply unit. The supply wire diameter must be selected in such way that the voltage drop between supply output and the device would be lower than 1V. The proper wire diameter is especially critical when device is located in long distance from the supply source. In such a case the use of dedicated power supply unit located close to the device should be considered. When separate power supply unit is used then its minus should be connected to controller's GND by means of signal wire with any diameter. It is recommended to use UTP cable for connection of device to controller. The table below shows maximal UTP cable lengths in relation to the number of wires used for power supply.

<b>Table 1. Power supply cabling</b>	
Number of UTP wire pairs for power supply	Maximal length of power supply cable
1	150m
2	300m
3	450m
4	600m

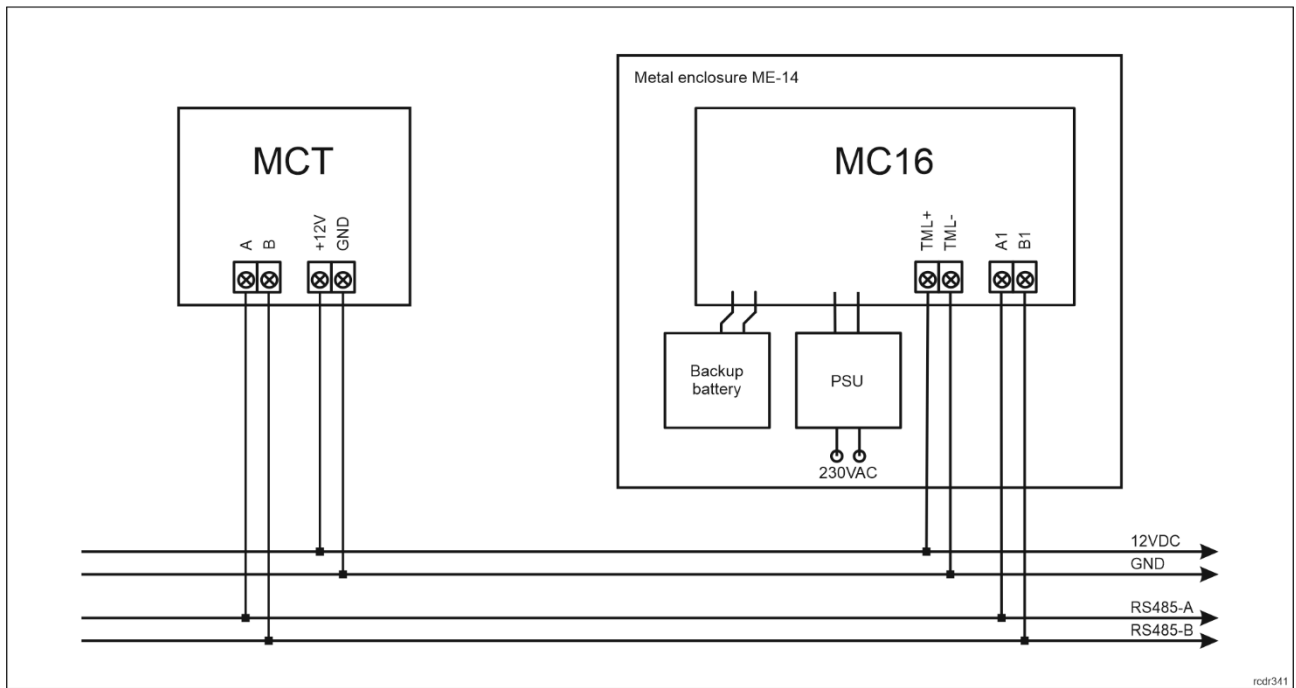

Fig. 1 MCT supply from MC16 access controller

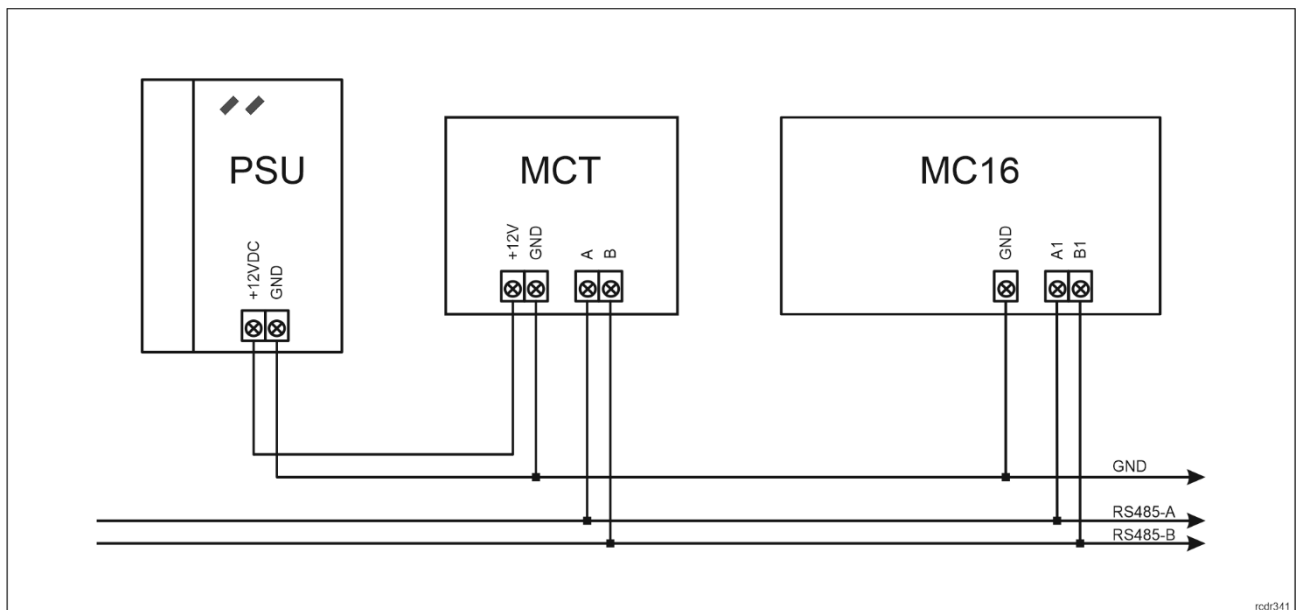

Fig. 2 MCT supply from dedicated power supply unit

RS485 bus

The communication method with MC16 access controller is provided with RS485 bus which can encompass up to 16 devices of RACS 5 system, each with unique address in range of 100-115. The bus topology can be freely arranged as star, tree or any combination of them except for loop. The matching resistors (terminators) connected at the ends of transmitting lines are not required. In most cases communication works with any cable type (standard telephone cable, shielded or unshielded twisted pair etc.) but the recommended cable is unshielded twisted pair (U/UTP cat.5). Shielded cables should be limited to installations subject to strong electromagnetic interferences. The RS485 communication standard used in the RACS 5 system guarantees proper communication in a distance of up to 1200 meters as well as high resistance to interferences.



---

Note: Do not use more than single pair in UTP cable for RS485 communication bus.

---

### LED indicators

The terminal is equipped with three LED indicators which are used to signal integral functions and they can be additionally programmed with other available functions within high level configuration (VISO).

<b>Table 2. LED indicators</b>			
Indicator	Symbol	Colour	Integral functions
LED STATUS		Red / green	Default colour of the indicator is red. If the terminal is assigned to Alarm Zone then the LED indicates zone arming (red) or disarming (green).
LED OPEN		Green	LED indicates access granting.
LED SYSTEM		Orange	LED indicates card reading and can signal other system functions including device malfunction.

---

Note: Synchronic pulsing of LED indicators signifies lost communication with MC16 controller.

---

### Buzzer

The terminal is equipped with buzzer which is used to signal integral functions and it can be additionally programmed with other available functions within high level configuration (VISO).

### Tamper detector

Built-in tamper (sabotage) detector enables detection of unauthorized opening of device's enclosure as well as detachment of the enclosure from wall. The detector is internally connected to the terminal's input. It does not require low level configuration (RogerVDM) or any additional installation arrangements but it is essential to mount front panel in such way as the tamper detector (fig. 4) would firmly press the back panel. The detector requires high level configuration which consists in assignment of the function [133] *Tamper Toggle* on the level of a *Main Board* of a controller in VISO software navigation tree.

### Identification

EM125kHz proximity cards are widely used in office buildings. If it is necessary to ensure higher level of security then MIFARE card readers e.g. MCT12M are recommended.

---

The technical characteristics of the device are guaranteed for RFID cards supplied by Roger. Cards from other sources may be used, but they are not covered by the manufacturer's warranty. Before deciding to use specific Roger products with third-party contactless cards, it is recommended to conduct tests that will confirm satisfactory operation with the specific Roger device and software in which it operates.

---

## 2. INSTALLATION

<b>Table 3. Screw terminals</b>	
Name	Description
12V	12VDC power supply
GND	Ground
A	RS485 bus, line A
B	RS485 bus, line B

MCT62E terminal

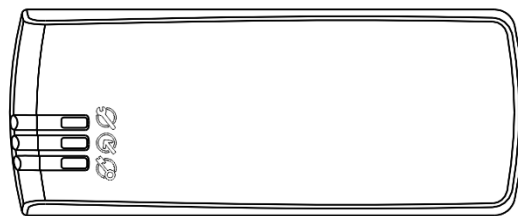
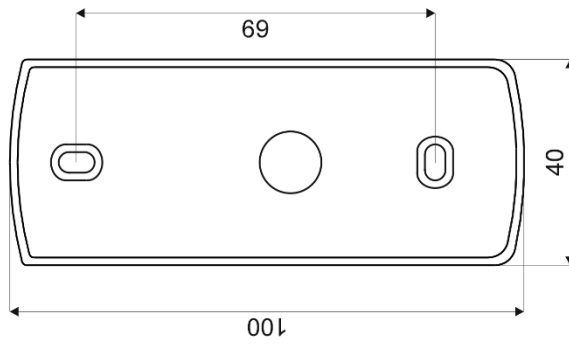
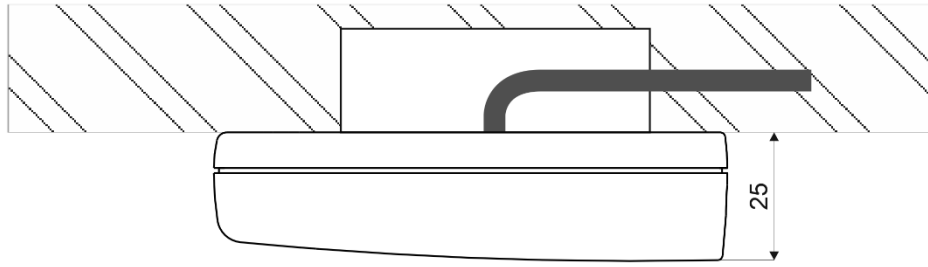

ref:307

Fig. 3 MCT62E installation

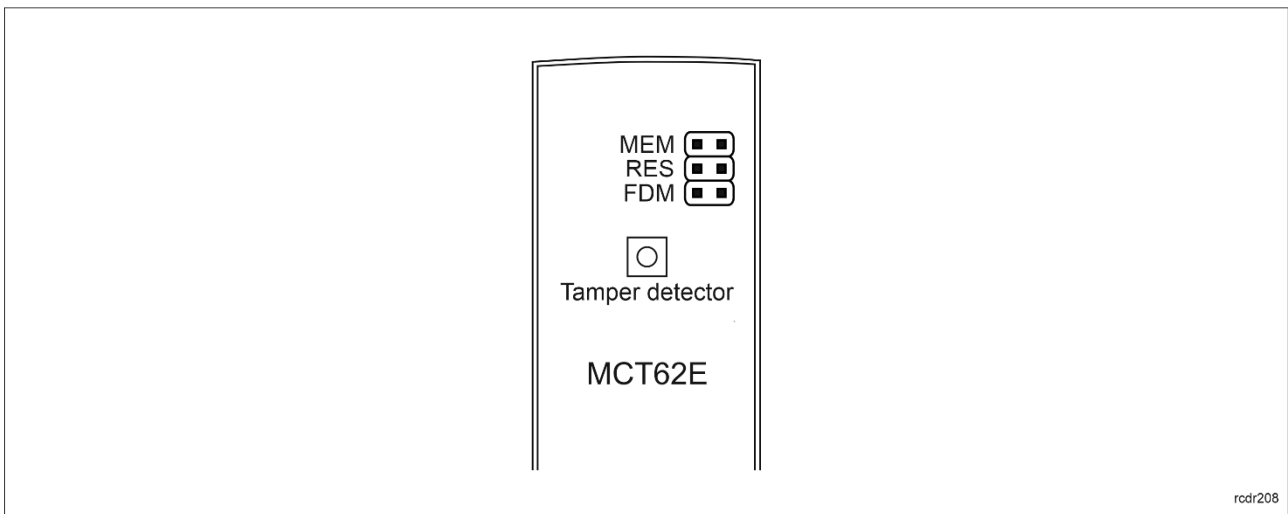

Fig. 4 Programming jumpers

### Installation guidelines

- The terminal should be mounted on a vertical structure (wall) away from sources of heat and moisture.
- Front panel should be attached in such way as the tamper detector (fig. 4) would firmly press the back panel.
- All electrical connections should be done with disconnected power supply.
- If the terminal and controller are not supplied from the same PSU then GND terminals of both devices must be connected with any wire.
- Device can be cleaned by means of wet cloth and mild detergent without abrasive components. In particular do not clean with alcohols, solvents, petrol, disinfectants, acids, rust removers, etc. Damages resulting from improper maintenance and usage are not covered by manufacturer warranty.
- The IP65 rating is guaranteed if the bottom of the housing is tightly adhered to the surface on which the device is installed. It is the installer's responsibility to seal the space between the bottom of the housing and the surface on which the device is mounted.

## 3. OPERATION SCENARIOS

The terminal when connected to MC16 access controller can be at the same time used for access control and Time&Attendance. The example of connection diagram for such scenario is shown in fig. 5 where inputs and outputs from MC16 board are used. The terminal can also operate with MC16 controller using MCX2D/MCX4D expanders as in case of M16-PAC-KIT series. Various scenarios of operation with MC16 controllers are presented in AN002 application note.

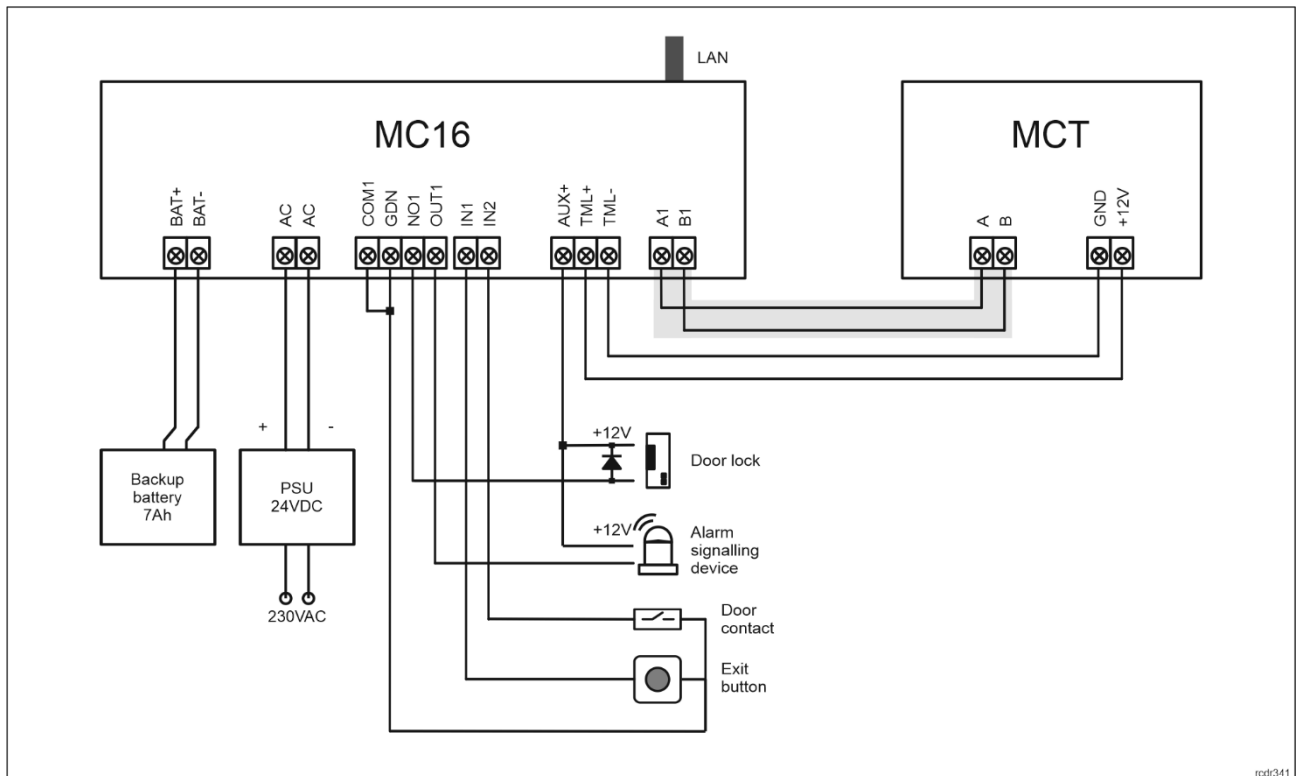

Fig. 5 Typical connection diagram for the terminal and MC16 access controller

## 4. CONFIGURATION

The purpose of low level configuration is to prepare device for operation in RACS 5 system. In case of RACS 5 v1 system the address of device must be configured by means of RogerVDM software or by manual addressing before connection to MC16 controller. While in RACS v2 system, low level configuration and addressing can be done with VISO v2 software during final configuration of the system. Therefore in RACS 5 v2 system the configuration from RogerVDM software and manual addressing are optional and during installation it is only necessary to properly connect the device to MC16 access controller.

### Low level configuration (VISO v2)

In RACS 5 v2 system the reader can be installed at site without previous configuration. According to AN006 application note, its address and other settings can be configured from VISO v2 management software and during such configuration the access to its service contacts (fig. 4) is not required.

### Low level configuration (RogerVDM)

Programming procedure with RogerVDM software (firmware 1.1.30.266 or newer):

1. Connect the device to RUD-1 interface (fig. 6) and connect the RUD-1 to computer's USB port.
2. Remove jumper from MEM contacts (fig. 4) if it is placed there.
3. Restart the device (switch power supply off and on or short RST contacts for a moment) and orange LED SYSTEM will pulsate. Then within 5 seconds place jumper on MEM contacts.
4. Start RogerVDM program, select *MCT* device, firmware version, *RS485* communication channel and serial port with RUD-1 interface.
5. Click *Connect*, the program will establish connection and will automatically display *Configuration* tab.
6. Enter unoccupied RS485 address in range of 100-115 and other settings according to requirements of specific installation.
7. Click *Send to Device* to update the configuration of device.
8. Optionally make a backup by clicking *Send to File...* and saving settings to file on disk.
9. Disconnect from RUD-1 interface and leave jumper on MEM contacts to enable further configuration of device from VISO v2 software or remove jumper from MEM contacts to block such remote configuration.

Programming procedure with RogerVDM software (firmware older than 1.1.30.266):

1. Connect the reader to RUD-1 interface (fig. 6) and connect the RUD-1 to computer's USB port.
2. Place jumper on MEM contacts (fig. 4).
3. Restart the reader (switch power supply off and on or short RST contacts for a moment) and orange LED SYSTEM will pulsate.
4. Start RogerVDM program, select *MCT* device, firmware version, *RS485* communication channel and serial port with RUD-1 interface.
5. Click *Connect*, the program will establish connection and will automatically display *Configuration* tab.
6. Enter unoccupied RS485 address in range of 100-115 and other settings according to requirements of specific installation.
7. Click *Send to Device* to update the configuration of device.
8. Optionally make a backup by clicking *Send to File...* and saving settings to file on disk.
9. Remove jumper from MEM contacts and disconnect device from RUD-1 interface.

Note: Do not read any cards when the device is configured with RogerVDM.

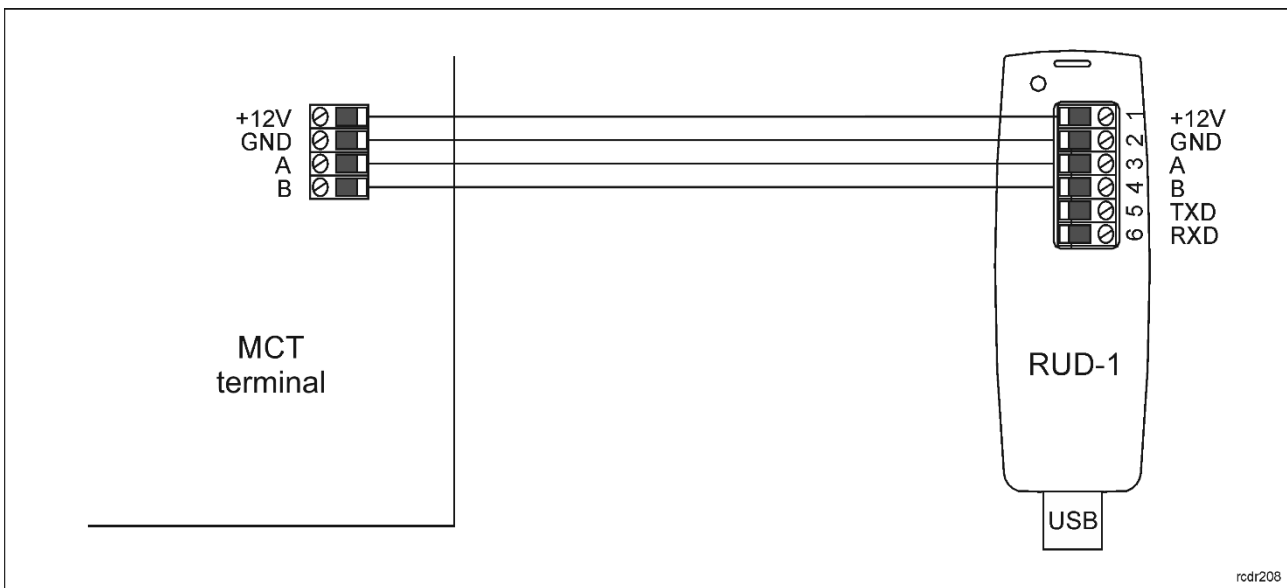

Fig. 6 Connection to RUD-1 interface (low level configuration)

<b>Table 4. List of low level parameters</b>	
<b>Communication settings</b>	
RS485 address	Parameter defines device address on RS485 bus. Range: 100-115. Default value: 100.
RS485 communication timeout [s]	Parameter defines delay after which device will signal lost communication with controller. When set to 0 then signaling is disabled. Range: 0-64s. Default value: 20s.
RS485 encryption	Parameter enables encryption at RS485 bus. Range: [0]: No, [1]: Yes. Default value: [0]: No.
RS485 encryption key	Parameter defines key for encryption of communication at RS485 bus. Range: 4-16 ASCII characters.
<b>Optical signalisation</b>	
LED SYSTEM pulsing when card near reader	Parameter enables LED SYSTEM (orange) pulsing when card is close to the device. Range: [0]: No, [1]: Yes. Default value: [0]: No.
Backlight switching off when no activity	Parameter enables backlight switching off after 20 s from the latest card reading or key pressing. The backlight is restored again when card or key is used. Range: [0]: No, [1]: Yes. Default value: [1]: Yes.
LED SYSTEM flash after card read	Parameter enables short flash of LED SYSTEM (orange) when card is read. Range: [0]: No, [1]: Yes. Default value: [1]: Yes.

<b>Acoustic signalisation</b>	
Buzzer loudness level [%]	Parameter defines buzzer loudness level. When set to 0 then buzzer is disabled Range: 0-100. Default value: 100.
Short sound after card read	Parameter enables short sound (beep) generating by buzzer when card is read. Range: [0]: No, [1]: Yes. Default value: [1]: Yes.
<b>Advanced settings</b>	
Stop card/PIN reading when buffer full	Parameter enables to reject card/PIN reading by device till previous card/PIN is transmitted to controller. Range: [0]: No, [1]: Yes. Default value: [0]: No.
Card/PIN buffer timeout [s]	Parameter defines time for card/PIN storing in device buffer. When the time elapses the buffer is cleared even if card/PIN is not transmitted to controller. Range: 1-64. Default value: 10.
Buffer overflow signalisation	Parameter enables LED SYSTEM (orange) switching on when card/PIN buffer is full. Range: [0]: No, [1]: Yes. Default value: [0]: No.
AF type	Parameter defines authentication factor type returned by terminal. Default value: [0010]: Number 40bits.
Long card read time [s]	Parameter defines long card read time. When set to 0 then long read is disabled. Range: 0-64. Default value: 0.
<b>Comments</b>	
DEV, KBD1, CDI1, IN1 (Tamper)	Parameter defines any text or comment which corresponds to the device/object. It is later displayed in VISO program.

## Manual addressing

Manual addressing procedure enables configuration of new RS485 address with all other settings unchanged.

### Manual addressing procedure (firmware 1.1.30.266 or newer):

1. Remove all connections from A and B lines.
2. Remove jumper from MEM contacts (fig. 4) if it is placed there.
3. Restart the device (switch power supply off and on or short RST contacts for a moment) and orange LED SYSTEM will pulsate. Then within 5 seconds place jumper on MEM contacts.
4. Enter 3 digits of RS485 address in range of 100-115 with any EM 125kHz card.
5. Leave jumper on MEM contacts to enable further configuration of device from VISO v2 software or remove jumper from MEM contacts to block such remote configuration.
6. Restart the device.

### Manual addressing procedure (firmware older than 1.1.30.266):

1. Remove all connections from A and B lines.
2. Place jumper on MEM contacts (fig. 4).
3. Restart the device (switch power supply off and on or short RST contacts for a moment) and orange LED SYSTEM will pulsate.
4. Enter 3 digits of RS485 address in range of 100-115 with any EM 125kHz card.
5. Remove jumper from MEM contacts and restart the device.

Readers without keypad can be addressed with multiple card readings where the N number of readings emulates digit of the address. Three series of readings with any EM125kHz proximity card are necessary to set the address. After each series wait for two beeps and proceed with the next digit. Zero digit is emulated with 10 readings.

### Example:

Programming of ID=101 address with card readings:

1. Read card 1 time and wait for two beeps.
2. Read card 10 times and wait for two beeps.
3. Read card 1 time and wait for two beeps.
4. Wait till reader is restarted with the new address.

## Memory reset

Memory reset procedure resets all settings to factory default ones including ID=100 address.

### Memory reset procedure (firmware 1.1.30.266 or newer):

1. Remove all connections from A and B lines.
2. Remove jumper from MEM contacts (fig. 4) if it is placed there.
3. Restart the device (switch power supply off and on or short RST contacts for a moment) and orange LED SYSTEM will pulsate. Then within 5 seconds place jumper on MEM contacts.
4. Read any EM 125kHz card 11 times.
5. Wait till device confirms reset with long acoustic signal.
6. Leave jumper on MEM contacts to enable further configuration of device from VISO software and disconnect device from RUD-1 interface.
7. Restart the device.

### Memory reset procedure (firmware older than 1.1.30.266):

1. Remove all connections from A and B lines.
2. Place jumper on MEM contacts (fig. 4).
3. Restart the device (switch power supply off and on or short RST contacts for a moment) and orange LED SYSTEM will pulsate.
4. Read any EM 125kHz card 11 times.
5. Wait till device confirms reset with long acoustic signal.
6. Remove jumper from MEM contacts and restart the device.

## High level configuration (VISO)

The purpose of high level configuration is to define logical functioning of the terminal which communicates with the MC16 access controller and it depends on applied scenario of operation. The example of access control system configuration is given in AN006 application note which is available at [www.roger.pl](http://www.roger.pl).

## 5. FIRMWARE UPDATE

The update requires connection of reader to computer with RUD-1 interface (fig. 7) and starting RogerVDM software. The latest firmware file is available at [www.roger.pl](http://www.roger.pl).

### Firmware update procedure:

1. Connect the reader to RUD-1 interface (fig. 7) and connect the RUD-1 to computer's USB port.
2. Place jumper on FDM contacts (fig. 4).
3. Restart the reader (switch power supply off and on or short RES contacts for a moment).
4. Start RogerVDM program and in the top menu select *Tools* and then *Update firmware*.
5. In the opened window select device type, serial port with RUD-1 interface and path to firmware file (\*.hex).
6. Click *Update* to start firmware upload with progress bar in the bottom.
7. When the update is finished, disconnect from RUD-1 interface and remove jumper from FDM contacts. Additionally it is recommended to start memory reset procedure.

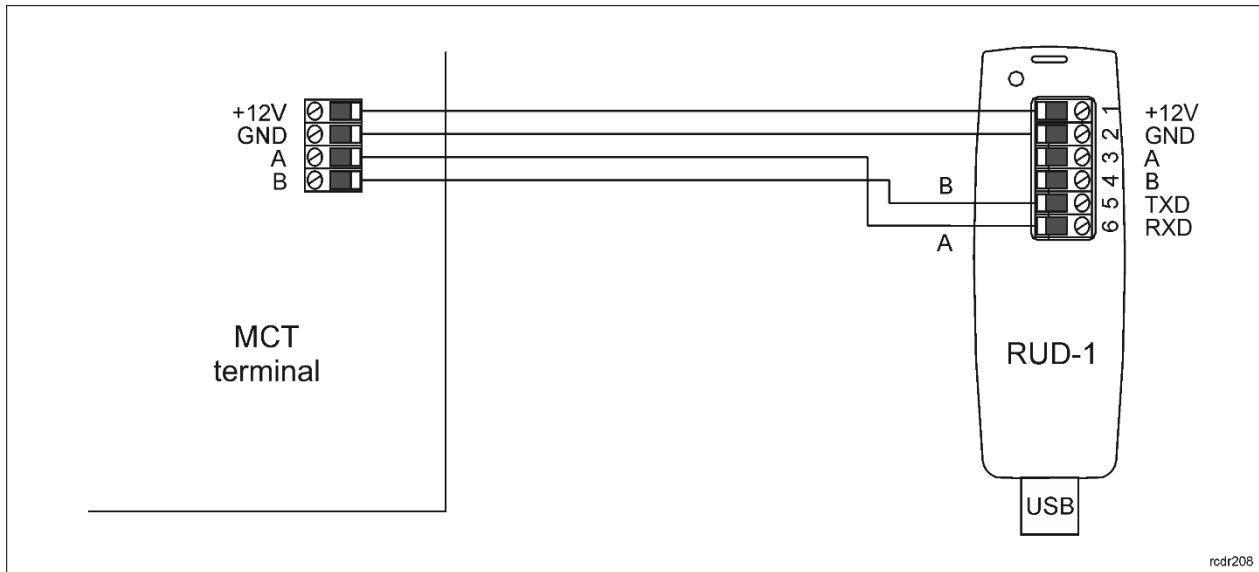

Fig. 7 Connection to RUD-1 interface (firmware update)

### 6. SPECIFICATION

Table 5. Specification	
Nominal supply voltage	12VDC
Nominal supply current	~50 mA
Tamper protection	Enclosure opening reported to access controller
Identification methods	EM 125 kHz UNIQUE according to EM4100/4102
Reading range	Up to 5 cm
Distance	1200 m maximal cable length for RS485 bus between controller and terminal
IK	IK09
IP	IP65
Environment	Outdoor general conditions, temperature: -25°C to +60°C, relative humidity: 10 to 75% (no condensation)
Dimensions HWD	100 x 40 x 25 mm
Weight	~100g
Compliance	CE, RoHS
Manufacturer's warranty	36 months

### 7. ORDERING INFORMATION

Table 6. Ordering information	
MCT62E	Access terminal; EM 125 kHz; communication interface RS485 EPSO 3 (RACS 5); 12 VDC supply; RADIUS series design; outdoor operation
RUD-1	Portable USB-RS485 communication interface dedicated to ROGER access control devices

### 8. PRODUCT HISTORY

Table 7. Product history		
Version	Date	Description
MCT62E v1.0	06/2017	The first commercial version of product

	<p>This symbol placed on a product or packaging indicates that the product should not be disposed of with other wastes as this may have a negative impact on the environment and health. The user is obliged to deliver equipment to the designated collection points of electric and electronic waste. For detailed information on recycling, contact your local authorities, waste disposal company or point of purchase. Separate collection and recycling of this type of waste contributes to the protection of the natural resources and is safe to health and the environment. Weight of the equipment is specified in the document.</p>
-----------------------------------------------------------------------------------	-------------------------------------------------------------------------------------------------------------------------------------------------------------------------------------------------------------------------------------------------------------------------------------------------------------------------------------------------------------------------------------------------------------------------------------------------------------------------------------------------------------------------------------------------------------------------------------------------------------------------------------------------

**Contact:****Roger sp. z o. o. sp.k.****82-400 Gościszewo 59****Tel.: +48 55 272 0132****Fax: +48 55 272 0133****Tech. support: +48 55 267 0126****E-mail: [support@roger.pl](mailto:support@roger.pl)**