

Roger Access Control System

MCT80M / MCT82M / MCT84M Installation Manual

Firmware version: x.1.30.266 and higher

Document version: Rev.D



This document contains minimum information that is necessary for initial setup and installation of the device. The detailed description of configuration parameters and functionalities is specified in respective Operating Manual available at www.roger.pl.

INTRODUCTION

The reader is designed for operation with MC16 access controller (RACS 5 system). Factory new reader is configured with default settings including ID=100 address.

DEVICE CONFIGURATION

The reader can be configured in regard of various parameters (including address) in order to adapt it to the requirements of specific installation. Device can be configured from VISO v2 management software or RogerVDM utility software.

Note: Remote configuration of device from VISO v2 software is possible only if jumper is placed on MEM contacts (fig. 4). If the jumper is removed then such configuration is blocked. In case of factory new device, jumper is placed on MEM contacts.

CONFIGURATION WITH VISO V2 PROGRAM

In RACS 5 v2 system the reader can be installed at site without previous configuration. According to AN006 application note, its address and other settings can be configured from VISO v2 management software and during such configuration the access to its service contacts (fig. 4) is not required.

CONFIGURATION WITH ROGERVDM PROGRAM

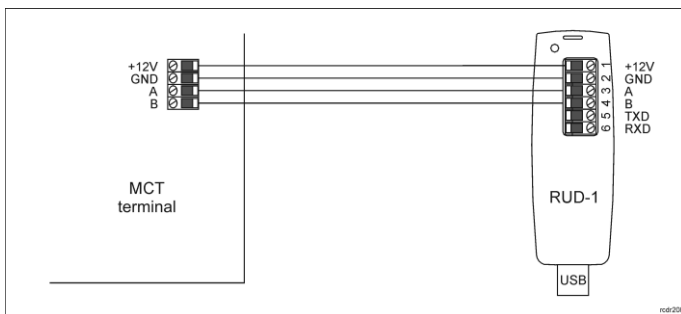

Fig. 1 Connection of MCT reader to RUD-1 interface (configuration)

Programming procedure:

1. Connect the device to RUD-1 interface (fig. 1) and connect the RUD-1 to computer's USB port.
2. Remove jumper from MEM contacts (fig. 4) if it is placed there.
3. Restart the device (switch power supply off and on or short RST contacts for a moment) and orange LED SYSTEM will pulsate. Then within 5 seconds place jumper on MEM contacts.
4. Start RogerVDM program, select MCT device, firmware version, RS485 communication channel and serial port with RUD-1 interface.
5. Click *Connect*, the program will establish connection and will automatically display *Configuration* tab.
6. Enter unoccupied RS485 address in range of 100-115 and other settings according to requirements of specific installation.
7. Click *Send to Device* to update the configuration of device.
8. Optionally make a backup by clicking *Send to File...* and saving settings to file on disk.
9. Disconnect from RUD-1 interface and leave jumper on MEM contacts to enable further configuration of device from VISO v2 software or remove jumper from MEM contacts to block such remote configuration.

Note: Do not read any cards nor press reader keypad when reader is configured with RogerVDM.

MANUAL ADDRESSING

Manual addressing procedure enables configuration of new RS485 address with all other settings unchanged.

Manual addressing procedure:

1. Remove all connections from A and B lines.
2. Remove jumper from MEM contacts (fig. 4) if it is placed there.

3. Restart the device (switch power supply off and on or short RST contacts for a moment) and orange LED SYSTEM will pulsate. Then within 5 seconds place jumper on MEM contacts.
4. Enter 3 digits of RS485 address in range of 100-115 with keypad or with any MIFARE card.
5. Leave jumper on MEM contacts to enable further configuration of device from VISO v2 software or remove jumper from MEM contacts to block such remote configuration.
6. Restart the device.

Readers without keypad can be addressed with multiple card readings where the N number of readings emulates digit of the address. Three series of readings with any MIFARE proximity card are necessary to set the address. After each series wait for two beeps and proceed with the next digit. Zero digit is emulated with 10 readings.

Example:

Programming of ID=101 address with card readings:

1. Read card 1 time and wait for two beeps.
2. Read card 10 times and wait for two beeps.
3. Read card 1 time and wait for two beeps.
4. Wait till reader is restarted with the new address.

MEMORY RESET

Memory reset procedure resets all settings to factory default ones including ID=100 address.

Memory reset procedure:

1. Remove all connections from A and B lines.
2. Remove jumper from MEM contacts (fig. 4) if it is placed there.
3. Restart the device (switch power supply off and on or short RST contacts for a moment) and orange LED SYSTEM will pulsate. Then within 5 seconds place jumper on MEM contacts.
4. Press [*] or read any MIFARE card 11 times.
5. Wait till device confirms reset with long acoustic signal.
6. Leave jumper on MEM contacts to enable further configuration of device from VISO v2 software or remove jumper from MEM contacts to block such remote configuration.
7. Restart the device.

FIRMWARE UPDATE

The firmware of device can be changed to newer or older version. The update requires connection to computer with RUD-1 interface (fig. 2) and starting RogerVDM software. The latest firmware file is available at www.roger.pl.

Firmware update procedure:

1. Connect the device to RUD-1 interface (fig. 2) and connect the RUD-1 to computer's USB port.
2. Place jumper on FDM contacts (fig. 4).
3. Restart the device (switch power supply off and on or short RST contacts for a moment).
4. Start RogerVDM program and in the top menu select *Tools* and then *Update firmware*.
5. In the opened window select device type, serial port with RUD-1 interface and path to main firmware file (*.hex) and in case of device with keypad also path to additional firmware file (*.cyacd).
6. Click *Update* to start firmware upload with progress bar in the bottom.
7. When the update is finished, disconnect from RUD-1 interface and remove jumper from FDM contacts. Additionally it is recommended to start memory reset procedure.

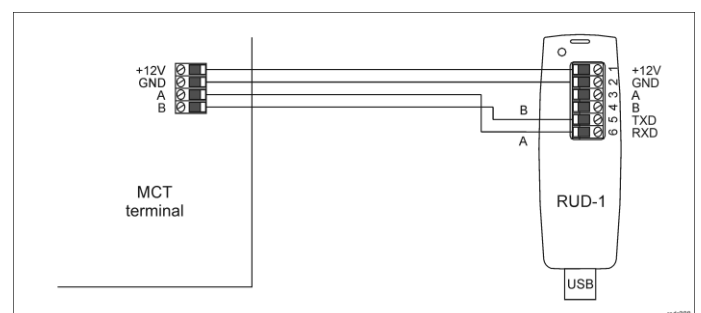

Fig. 2 Connection of MCT reader to RUD-1 interface (firmware update)

APPENDIX

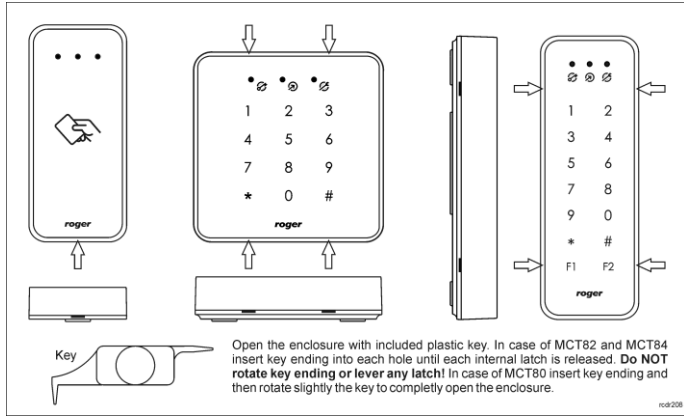

Fig. 3 Enclosure opening

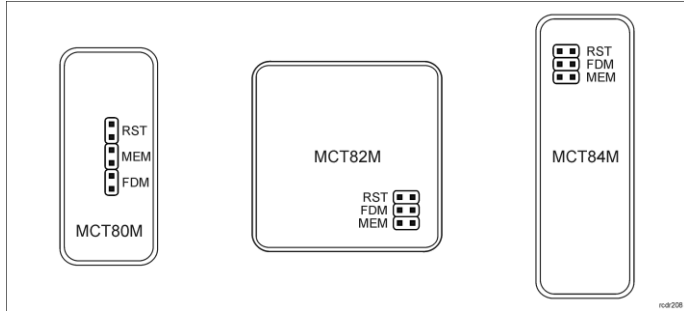

Fig. 4 Service contacts

Table 1. Screw terminals and wires		
Name	Wire colour (MCT80M)	Description
12V	Red	Supply plus
GND	Black	Ground
A	Yellow	RS485 bus, line A
B	Green	RS485 bus, line B
IN1		IN1 input line
IN2		IN2 input line
IN3		IN3 input line
IO1		IO1 output line
IO2		IO2 output line
NC		REL1 relay output (NC)
COM		REL1 relay common terminal
NO		REL1 relay output (NO)

Table 2. Specification	
Supply voltage	Nominal 12VDC, min./max. range 10-15VDC
Current consumption (average)	MCT80M: ~60 mA MCT82M/MCT82M-IO: ~60 mA MCT82M-BK/MCT82M-BK-IO: ~45 mA MCT84M: ~65 mA MCT84M-BK: ~50 mA
Inputs	In IO version: Three parametric inputs (IN1..IN3) internally connected to the power supply plus through a 5.6kΩ resistor. Approx. 3.5V triggering level for NO and NC inputs.
Relay output	In IO version: Relay output (REL1) with single NO/NC contact, 30V/1.5A DC/AC max. load
Transistor outputs	In IO version: Two (IO1, IO2) open collector outputs with pull-up to +12V through a 15kΩ resistor, 15VDC/150mA max. load
Tamper protection	Enclosure opening reported to access controller
Proximity cards	13.56MHz MIFARE Ultralight, Classic
Reading range	Up to 7 cm
Distance	1200m maximal cable length for RS485 bus between controller and reader
IP Code	MCT80M series: IP65 MCT82M/MCT84M series: IP30
Environmental class (according to EN 50133-1)	MCT80M: Class IV, outdoor general conditions, temperature: -25°C to +60°C, relative humidity: 10 to 95% (no condensation) MCT82M/MCT84M series: Class II, indoor general conditions, temperature: -10°C to +50°C, relative humidity: 10 to 95% (no condensation)
Dimensions H x W x D	MCT80M series: 100 x 45 x 16 mm MCT82M series: 85 x 85 x 22 mm MCT84M series: 130 x 45 x 22 mm
Weight	MCT80M: ~100g

	MCT82M series: ~100g
	MCT84M series: ~100g
Certificates	CE

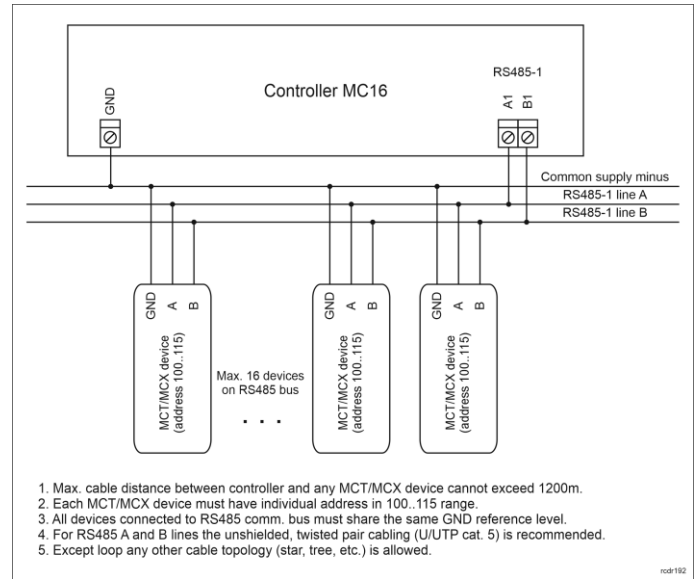

Fig. 5 Connection of readers and expanders to MC16 access controller

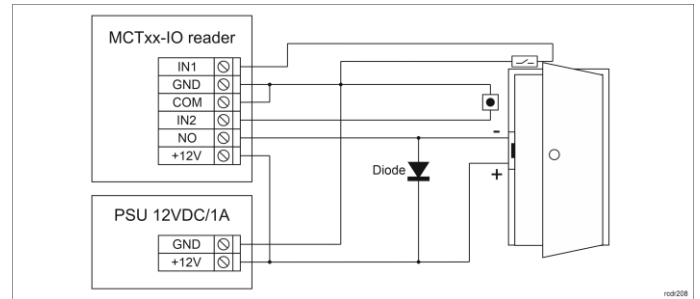
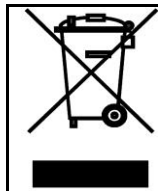

Fig. 6 Connection of door lock, door contact and exit button to MCTxx-IO reader



This symbol placed on a product or packaging indicates that the product should not be disposed of with other wastes as this may have a negative impact on the environment and health. The user is obliged to deliver equipment to the designated collection points of electric and electronic waste. For detailed information on recycling, contact your local authorities, waste disposal company or point of purchase. Separate collection and recycling of this type of waste contributes to the protection of the natural resources and is safe to health and the environment. Weight of the equipment is specified in the document.

Contact:
Roger Sp. z o. sp. k.
 82-400 Sztum
 Gościszewo 59
 Tel.: +48 55 272 0132
 Fax: +48 55 272 0133
 Tech. support: +48 55 267 0126
 E-mail: support@roger.pl
 Web: www.roger.pl