

# Roger Access Control System

## MCT62E Reader

### Installation Manual

Hardware version: v1.0  
Firmware version: 1.1.30.266 and newer

Document version: Rev. F

This document contains minimum information that is necessary for initial setup and installation of the device. The detailed description of configuration parameters and functionalities is specified in respective Operating Manual available at [www.roger.pl](http://www.roger.pl). This document is subject to the Terms of Use in the current version published on the website [www.roger.pl](http://www.roger.pl). The manufacturer reserves the right to make changes to the product without prior notice. © ROGER sp. z o. o. sp.k. All rights reserved.

## INTRODUCTION

The reader is designed for operation with MC16 access controller (RACS 5 system). Factory new reader is configured with default settings including ID=100 address.

## DEVICE CONFIGURATION

The reader can be configured in regard of various parameters (including address) in order to adapt it to the requirements of specific installation. Device can be configured from VISO v2 management software or RogerVDM utility software.

Note: Remote configuration of device from VISO v2 software is possible only if jumper is placed on MEM contacts (fig. 3). If the jumper is removed then such configuration is blocked. In case of factory new device, jumper is placed on MEM contacts.

## CONFIGURATION WITH VISO v2 PROGRAM

In RACS 5 v2 system the reader can be installed at site without previous configuration. According to AN006 application note, its address and other settings can be configured from VISO v2 management software and during such configuration the access to its service contacts (fig. 3) is not required.

## CONFIGURATION WITH ROGERVDM PROGRAM

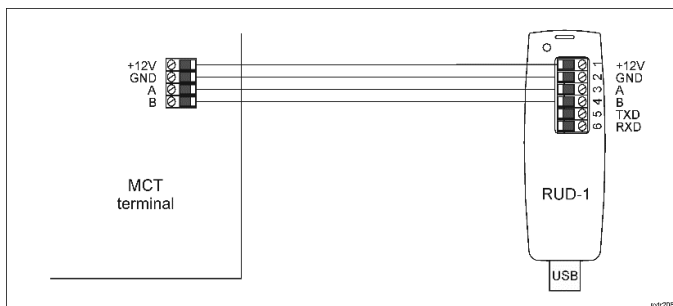

Fig. 1 Connection of MCT terminal to RUD-1 interface

## Programming procedure:

1. Connect the device to RUD-1 interface (fig. 1) and connect the RUD-1 to computer's USB port.
2. Remove jumper from MEM contacts (fig. 3) if it is placed there.
3. Restart the device (switch power supply off and on or short RST contacts for a moment) and orange LED SYSTEM will pulsate. Then within 5 seconds place jumper on MEM contacts.
4. Start RogerVDM program, select *MCT* device, firmware version, *RS485* communication channel and serial port with RUD-1 interface.
5. Click *Connect*, the program will establish connection and will automatically display *Configuration* tab.
6. Enter unoccupied RS485 address in range of 100-115 and other settings according to requirements of specific installation.

7. Click *Send to Device* to update the configuration of device.
8. Optionally make a backup by clicking *Send to File...* and saving settings to file on disk.
9. Disconnect from RUD-1 interface and leave jumper on MEM contacts to enable further configuration of device from VISO v2 software or remove jumper from MEM contacts to block such remote configuration.

Note: Do not read any cards when reader is configured with RogerVDM.

## MANUAL ADDRESSING

Manual addressing procedure enables configuration of new RS485 address with all other settings unchanged.

### Manual addressing procedure:

1. Remove all connections from A and B lines.
2. Remove jumper from MEM contacts (fig. 3) if it is placed there.
3. Restart the device (switch power supply off and on or short RST contacts for a moment) and orange LED SYSTEM will pulsate. Then within 5 seconds place jumper on MEM contacts.
4. Enter 3 digits of RS485 address in range of 100-115 with any EM 125kHz card.
5. Leave jumper on MEM contacts to enable further configuration of device from VISO v2 software or remove jumper from MEM contacts to block such remote configuration.
6. Restart the device.

Readers without keypad can be addressed with multiple card readings where the N number of readings emulates digit of the address. Three series of readings with any EM 125kHz proximity card are necessary to set the address. After each series wait for two beeps and proceed with the next digit. Zero digit is emulated with 10 readings.

### Example:

Programming of ID=101 address with card readings:

1. Read card 1 time and wait for two beeps.
2. Read card 10 times and wait for two beeps.
3. Read card 1 time and wait for two beeps.
4. Wait till reader is restarted with the new address.

## MEMORY RESET

Memory reset procedure resets all settings to factory default ones including ID=100 address.

### Memory reset procedure:

1. Remove all connections from A and B lines.
2. Remove jumper from MEM contacts (fig. 3) if it is placed there.
3. Restart the device (switch power supply off and on or short RST contacts for a moment) and orange LED SYSTEM will pulsate. Then within 5 seconds place jumper on MEM contacts.
4. Read any EM 125kHz card 11 times.
5. Wait till device confirms reset with long acoustic signal.
6. Leave jumper on MEM contacts to enable further configuration of device from VISO v2 software or remove jumper from MEM contacts to block such remote configuration.
7. Restart the device.

## FIRMWARE UPDATE

The firmware of device can be changed to newer or older version. The update requires connection to computer with RUD-1 interface (fig. 2) and starting RogerVDM software. The latest firmware file is available at [www.roger.pl](http://www.roger.pl).

Note: Backup configuration with RogerVDM software before firmware update because the update will restore factory default settings.

### Firmware update procedure:

1. Connect the reader to RUD-1 interface (fig. 2) and connect the RUD-1 to computer's USB port.
2. Place jumper on FDM contacts (fig. 3).
3. Restart the reader (switch power supply off and on or short RES contacts for a moment).
4. Start RogerVDM program and in the top menu select *Tools* and then *Update firmware*.
5. In the opened window select device type, serial port with RUD-1 interface and path to firmware file (\*.hex).
6. Click *Update* to start firmware upload with progress bar in the bottom.

- When the update is finished, disconnect from RUD-1 interface and remove jumper from FDM contacts. Additionally it is recommended to start memory reset procedure.

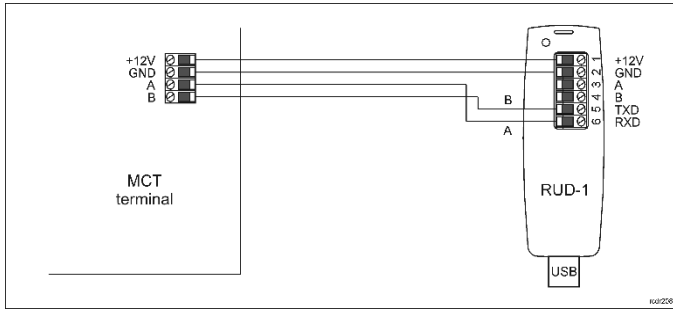

Fig. 2 Connection of MCT reader to RUD-1 interface for firmware update

## INSTALLATION

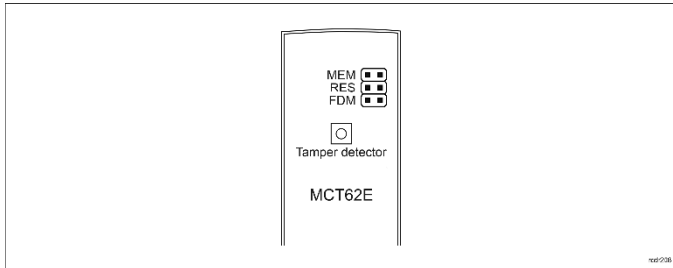

Fig. 3 Enclosure opening and location of service contact.

**Table 1. Wires**

Name	Description
12V	Supply plus
GND	Ground
A	RS485 bus, line A
B	RS485 bus, line B

### Installation guidelines

- The terminal should be mounted on a vertical structure (wall) away from sources of heat and moisture.
- Front panel should be attached in such way as the tamper detector would firmly press the back panel.
- All electrical connections should be done with disconnected power supply.
- If the device is installed in a place exposed to conductive dust (e.g. metal dust), protect the MEM/RST/FDM pins with insulating mass, e.g. silicone, after installation.
- If the terminal and controller are not supplied from the same PSU then GND terminals of both devices must be connected with any wire.
- Device can be cleaned by means of wet cloth and mild detergent without abrasive components. In particular do not clean with alcohols, solvents, petrol, disinfectants, acids, rust removers, etc. Damages resulting from improper maintenance and usage are not covered by manufacturer warranty.
- The IP65 rating is guaranteed if the bottom of the housing is tightly adhered to the surface on which the device is installed. It is the installer's responsibility to seal the space between the bottom of the housing and the surface on which the device is mounted.

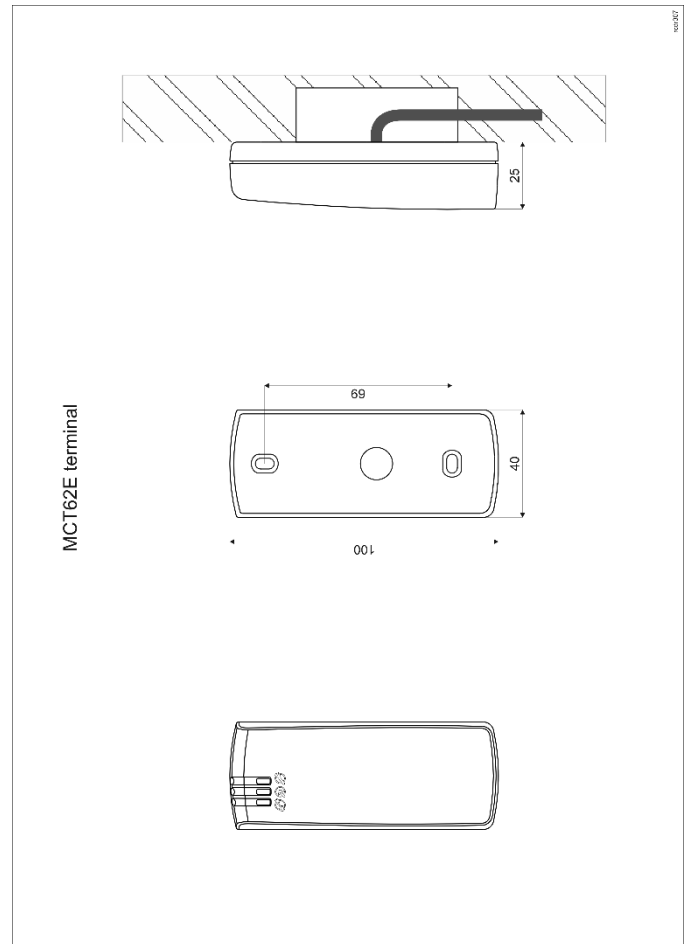

Fig. 4 MCT62E installation.

## APPENDIX

**Table 2. Specification**

Nominal supply voltage	12VDC
Nominal supply current	~50 mA
Tamper protection	Enclosure opening reported to access controller
Identification methods	EM 125 kHz UNIQUE according to EM4100/4102
Reading range	Up to 5 cm
Distance	1200 m maximal cable length for RS485 bus between controller and terminal
IK	IK09
IP	IP65
Environment	Outdoor general conditions, temperature: -25°C to +60°C, relative humidity: 10 to 75% (no condensation)
Dimensions HWD	100 x 40 x 25 mm
Weight	~100g
Compliance	CE, RoHS
Manufacturer's warranty	36 months

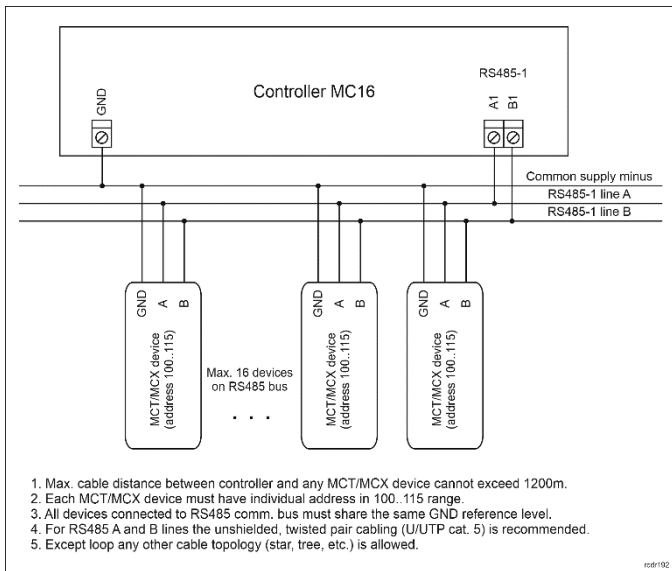



Fig. 4 Connection of terminals and expanders to MC16 access controller

Table 3. Ordering information	
MCT62E	Access terminal; EM 125 kHz; communication interface RS485 EPSO 3 (RACS 5); 12 VDC supply; RADIUS series design; outdoor operation
RUD-1	Portable USB-RS485 communication interface dedicated to ROGER access control devices

Table 4. Product history		
Version	Date	Description
MCT62E v1.0	06/2017	The first commercial version of product

 This symbol placed on a product or packaging indicates that the product should not be disposed of with other wastes as this may have a negative impact on the environment and health. The user is obliged to deliver equipment to the designated collection points of electric and electronic waste. For detailed information on recycling, contact your local authorities, waste disposal company or point of purchase. Separate collection and recycling of this type of waste contributes to the protection of the natural resources and is safe to health and the environment. Weight of the equipment is specified in the document.

**Contact:**  
**Roger Sp. z o. o. sp. k.**  
**82-400 Sztum**  
**Gościszewo 59**  
**Tel.: +48 55 272 0132**  
**Fax: +48 55 272 0133**  
**Tech. support: +48 55 267 0126**  
**E-mail: [support@roger.pl](mailto:support@roger.pl)**  
**Web: [www.roger.pl](http://www.roger.pl)**