

Roger Access Control System

MCX2D Operating Manual

Product version: 1.0

Firmware version: 1.1.18 or newer

Document version: Rev. L



*This document is subject to the Terms of Use in the current version published on the website www.roger.pl
The manufacturer reserves the right to make changes to the product without prior notice. © ROGER sp. z o.
o. sp.k. All rights reserved.*

1. DESIGN AND APPLICATION

MCX2D is I/O expander dedicated to RACS 5 system. The device after connection to MC16 access controller and MCT series terminals enables to control 2 doors. The expander offers I/Os and distributes power supply and RS485 communication bus. The expander operates with backup battery which depending on particular requirements can be charged with 0.3A, 0.6A or 0.9A current. The expander is equipped with removable terminal blocks which facilitate electrical connections during installation and maintenance. MCX2D expander is offered separately as an electronic module for installation in a metal housing with a power supply or as a part of MC16-PAC-2-KIT.

Characteristics

- RACS 5 system I/O expander
- Power supply distribution for door devices
- RS485 bus distribution for MCT terminals
- 4 parametric (EOL) inputs
- 4 transistor outputs
- 6 power supply outputs
- Backup battery charging
- RS485 interface
- Removable screw terminals
- Compliance: CE, RoHS

Power supply

The expander requires 13.8VDC power supply and it is recommended to apply PS2D power supply unit for that purpose. Due to relatively high current between expander and PSU, all connections should be made using possibly short cables with adequate cross sections. PSxD series PSUs (Roger) are offered with two 30cm/1mm² cables dedicated to supply the expander. Multiple MCX2D expanders can be supplied from the same PSU and in such case each connection must be made with individual pair of cables. When expander's supply voltage is too low then the battery cannot be fully charged and when the voltage is too high then the battery can be damaged. MCX2D which is supplied from PSU equipped with own backup (e.g. UPS) can be supplied with 12VDC but then it cannot be equipped with its own backup battery.

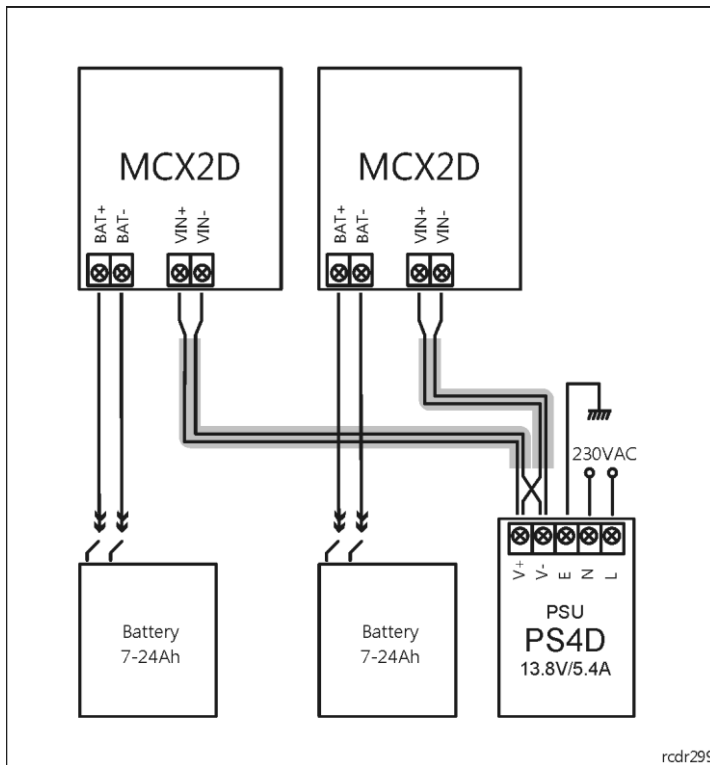

Fig. 1 Two MCX2D expanders supplied from the same PSU

Backup battery

MCX2D enables battery charging with 0.3A, 0.6A or 0.9A current up to the level of voltage supplied to the expander (nominal 13.8VDC). The charging current is selected with jumpers (fig. 2). When battery voltage drops to approximately 10V then it is disconnected from the expander. The battery is reconnected when the 13.8V supply is restored. In order to ensure battery charging up to 80% level within 24h (according to EN 60839 standard) following current settings should be applied:

- 300mA for 7Ah battery
- 600mA for 17Ah battery
- 900mA for 24Ah battery

RS485 interface

MCX2D is an addressable device connected to RS485 communication bus of the access controller. At the same time the expander distributes the RS485 lines to MCT terminals at each door. The expander can be operated with default ID=100 address or it can be assigned with the address in range of 101-115. All devices connected to access controller including MCX expanders and MCT terminals must have unique addresses in range of 100-115. MCX2D is addressed during *low level configuration* by means of RogerVDM software or manually during memory reset procedure.

In most cases communication on RS485 works with any cable type (standard telephone cable, shielded or unshielded twisted pair etc.) but the recommended cable is unshielded twisted pair (U/UTP cat.5). Shielded cables should be only used in installations subject to strong electromagnetic interferences. The RS485 communication standard used in the RACS 5 system guarantees proper communication in a distance of up to 1200 meters as well as high resistance to interferences. If the expander and controller are powered by separate power supplies, it is necessary to short-circuit the expander's power supply minus (GND) with the controller's power supply minus (GND) using a separate wire of any small cross-section.

LED indicators

Expanders are equipped with LED indicators which are used to signal integral functions. According to further mentioned procedures, the service mode is started by restarting the expander and placing jumper on MEM contacts.

Table 1. LED indicators		
Indicator	Colour	Integral functions
ACL	Red	In normal mode the LED indicates backup power supply from battery instead of PSU.
RUN	Red	Single pulse every 4 sec. : normal mode Quick pulsing: service mode Slow pulsing (0.5s/0.5s): No communication with controller Very slow pulsing (1s/1s): Configuration memory error In case of Memory reset this LED is used for manual addressing.
TXD	Red	LED indicates data transmission to controller
RXD	Green	LED indicates data receiving from controller
VDR, TML, VOUT, AUX	Green	LED indicates voltage at particular output.
LCK, BELL	Red	LED is on when corresponding LCK output is switched on.

Inputs

Expander offers DC and DR parametric inputs of NO, NC, 3EOL/DW/NO and 3EOL/DW/NC type. Input types and electric parameters such as response time and parametric resistors are defined within low level configuration (VISO v2 or RogerVDM). Input functions are assigned within high level configuration (VISO). Multiple functions can be assigned to the same input at the same time.

In standard scenario of door control, DC inputs are dedicated to connection of door contacts while DR inputs are dedicated to connection of exit buttons and they do not require low level configuration as they can be operated with default settings:

- DC inputs: NC type / 50ms response time
- DR inputs: NO type / 50ms response time

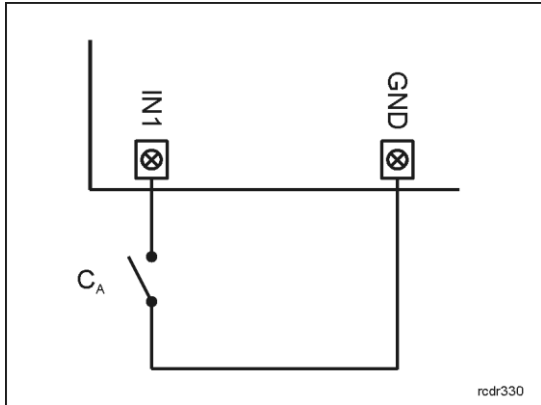
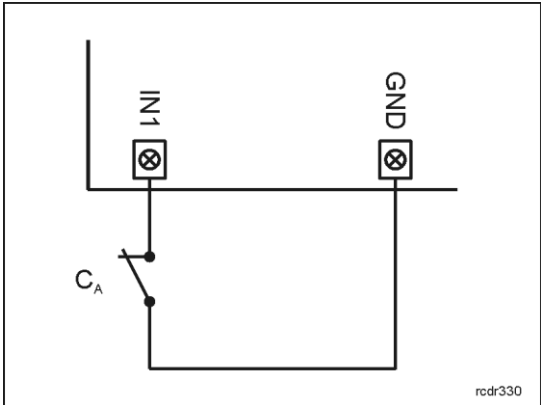
Table 2. Input types	
<p>NO input</p>  <p>NO input can be in normal or in triggered state. In normal state C_A contacts are opened. Input triggering is caused by C_A contacts closing.</p>	<p>NC input</p>  <p>NC input can be in normal or in triggered state. In normal state C_A contacts are closed. Input triggering is caused by C_A contacts opening.</p>

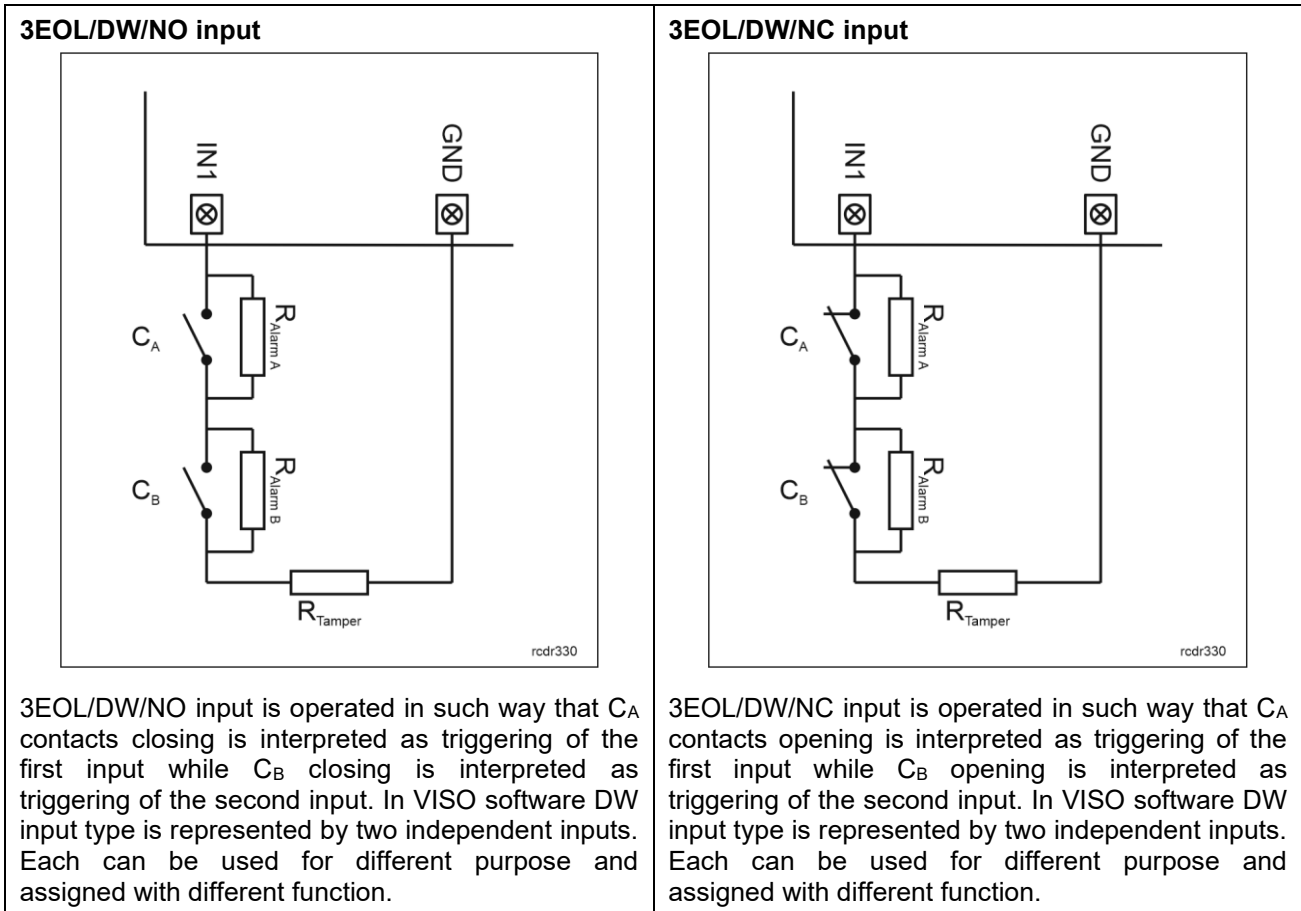

Parametric resistors

The same values of parametric resistors are used for all inputs i.e. 1kΩ; 1,2kΩ; 1,5kΩ; 1,8kΩ; 2,2kΩ; 2,7kΩ; 3,3kΩ; 3,9kΩ; 4,7kΩ; 5,6kΩ; 6,8kΩ; 8,2kΩ; 10kΩ; 12kΩ. In case of 3EOL/DW (Double Wiring) input type, Alarm A resistor defines a value of resistor used to detect triggering of the first input while Alarm B resistor defines a value of resistor used to detect triggering of the second input. Alarm A resistor value must differ from value of Alarm B resistor at least by three positions in the list above. Total resistance of wire used to connect contacts to input should not exceed 100 Ω. Default values of parametric resistors:

- Alarm A = 2,2 kΩ
- Alarm B = 5,6 kΩ
- Tamper = 1,0 kΩ

Response time

Response time parameter defines minimal impulse time on the input which triggers the input. Each input can be configured individually in range of 50 to 5000 ms within low level configuration (VISO v2 or RogerVDM).

Transistor outputs

Expander offers LCK and BELL open collector type transistor outputs. Electric parameters such as polarity are configured within *low level configuration* (VISO v2 or RogerVDM). Function are assigned to outputs within *high level configuration* (VISO). In standard scenario of door control, LCK outputs are dedicated to control door locks while BELL outputs are dedicated to control alarm signalling devices and/or door bells. In standard scenario of operation both LCK and BELL outputs do not require low level configuration.

Power supply outputs

Expander offers 6 outputs to provide power supply to access controller, terminals, door locks and other external devices.

VDR outputs

VDR power supply output is dedicated to supply door lock, alarm signalling device and other door related devices. The terminal VDR+ is protected with 1.0A electronic fuse. The terminal VDR- is internally shorted to ground (GND). Green LED indicator is located at the VDR+ terminal to signal voltage at the output.

TML outputs

TML power supply output is dedicated to supply readers at door. The terminal TML+ is protected with 0.2A electronic fuse . The terminal TML- is internally shorted to ground. Green LED indicator is located at the TML+ terminal to signal voltage at the output.

VOUT output

VOUT power supply output is dedicated to supply additional electronic modules and it can be also used to supply access controller. The terminal VOUT+ is protected with 0.2A electronic fuse . The terminal VOUT- is internally shorted to ground. Green LED indicator is located at the VOUT+ terminal to signal voltage at the output.

Note: If MC16 access controller is supplied from the expander then it cannot be at the same time supplied by its own PSU and cannot operate with its own backup battery.

AUX output

AUX power supply output is dedicated to supply optional electronic modules. The terminal AUX+ is protected with 0.2A electronic fuse. The terminal AUX- is internally shorted to ground. Green LED indicator is located at the AUX+ terminal to signal voltage at the output.

2. INSTALLATION

Note: The electronics module is sensitive to electrostatic discharge. Before performing any work on the module, ensure you are free of electrostatic charge by touching a grounded metal object with your bare hand.

The expander should be installed in a metal enclosure with a door and a power supply. The enclosure must be earthed by means of PE wire. The manufacturer offers a range of enclosures designed for electronic modules and equipped with power supplies. The installation site should be away from heat and moisture sources and protected from unauthorized access. The connection between the power supply and the expander should be made using a cable with a minimum cross-section of 0.5 mm² and a length of up to 50 cm. The PSxD series power supply comes with cables with a cross-section of 1 mm² and a length of 30 cm, which can be used to power the expander. All electrical lines connected to the expander must run inside the building or in underground cable ducts. All electrical connections should be made with the power off. The network circuit supplying the device must be equipped with an installation switch After completing installation and start-up, close the enclosure.

Installation may only be performed by a qualified person with the appropriate permits and authorizations for connecting and intervening in 230VAC and low-voltage networks. It is not permitted to use the enclosure without a properly installed and technically functional electric shock protection circuit (PE).

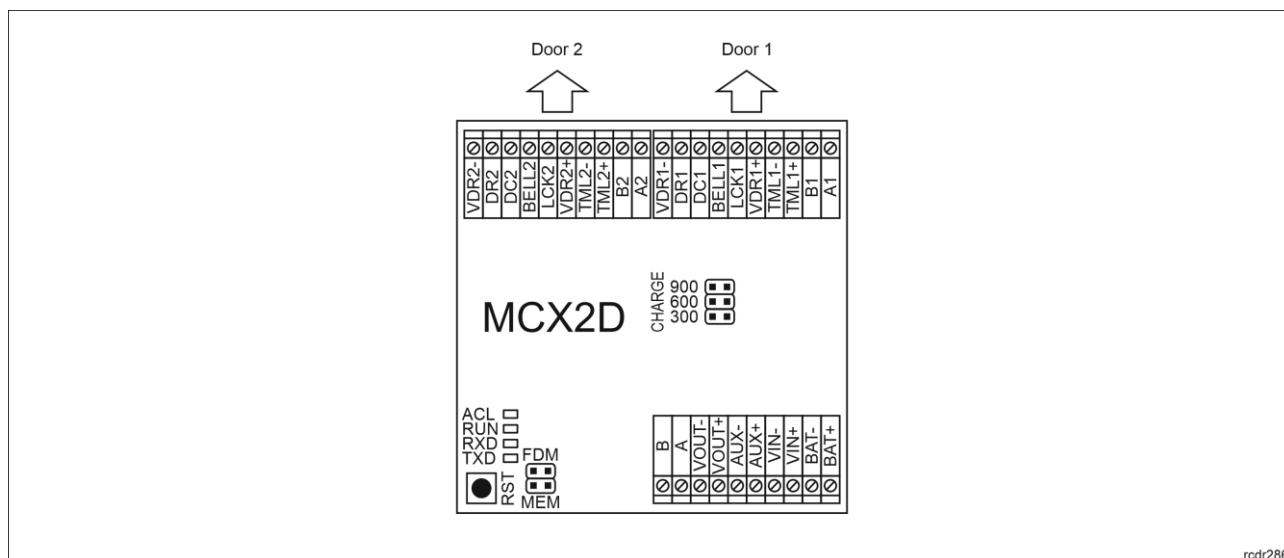

Fig. 2 MCX2D expander

Table 3. MCX2D screw terminals	
Name	Description
BAT+, BAT-	Backup battery
VIN+, VIN-	13.8VDC input power supply
AUX+, AUX-	13.8VDC/0.2A output power supply (for general purpose)
VOUT+, VOUT-	13.8VDC/0.2A output power supply (to controller)
A, B	RS485 bus (to controller)
Ax*, Bx	RS485 bus (to readers)
TMLx+, TMLx-	13.8VDC/0.2A output power supply (to readers)
VDRx+, VDRx-	13.8VDC/1.0A output power supply (to door lock)
LCKx	15VDC/1.0A transistor output line (door lock)
BELLx	15VDC/1.0A transistor output line (alarm signalling device)
DCx	Input line (door contact)
DRx	Input line (exit button)

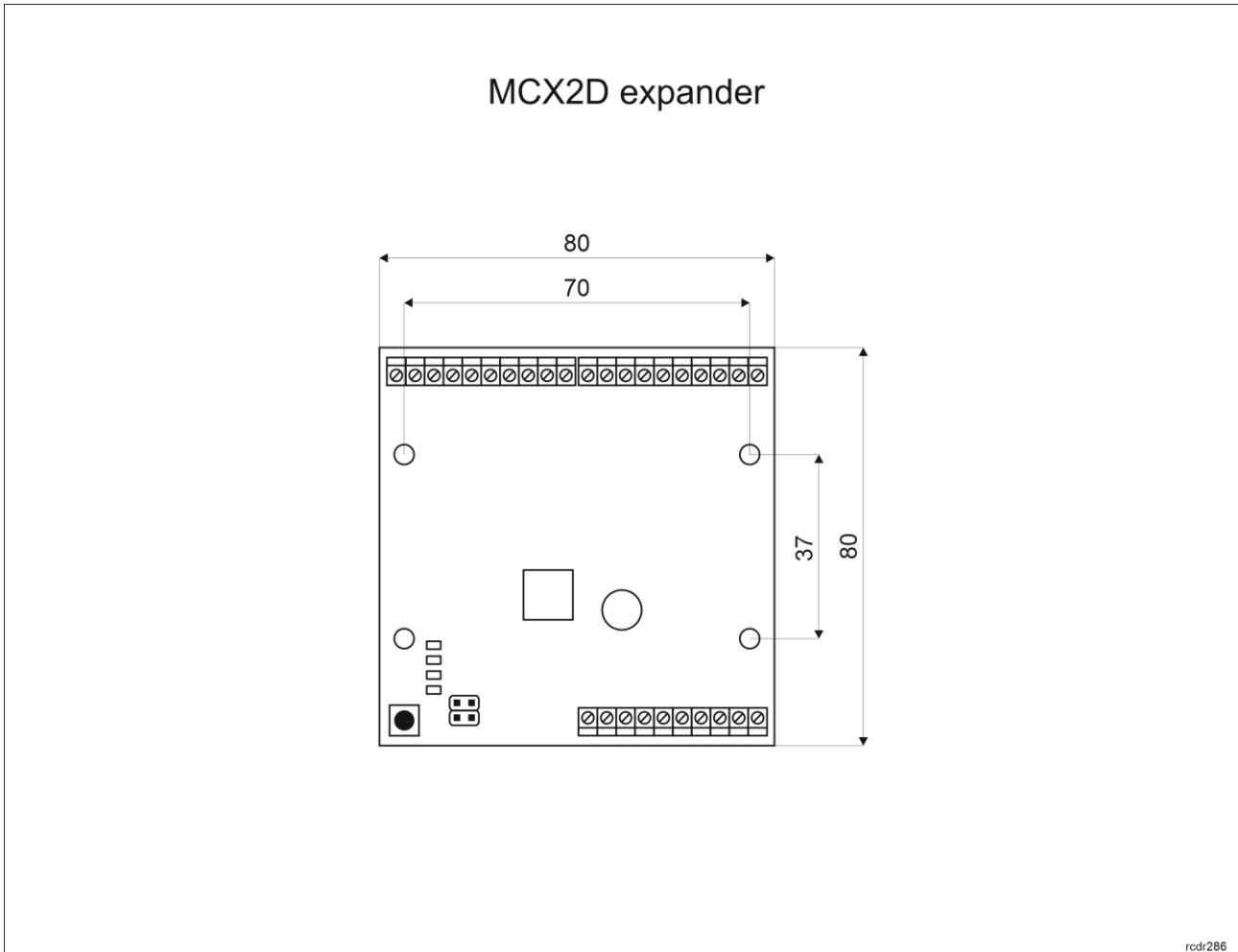

Fig. 3 MCX2D dimensions

3. OPERATION SCENARIOS

In typical scenario of operation, MCX2D expanders are used in MC16-PAC-2-KIT two-door access control kits (fig. 4 and 6). In the alternative scenario of operation, multiple MCX2D expanders are connected to multidoor MC16 access controller (fig. 5). In such scenario the maximal number of expanders operated by MC16 controller depends on its type and it is limited by available range of addresses ID=100-115 on RS485 bus of MC16 controller where all MCX and MCT devices must have unique addresses. For example, in case of read-in/out doors it is possible to control max. 6 doors in such setup as MC16-PAC-6 + 3 x MCX2D + 12 x MCT while in case of read-in doors it is possible to control max. 10 doors in such setup as MC16-PAC-10 + 5 x MCX2D + 10 x MCT. In both cases, 15 addresses on RS485 bus are occupied. It is also possible to mix read-in and read-in/out doors within single MC16 controller if the limitation related to the number of RS485 addresses is preserved.

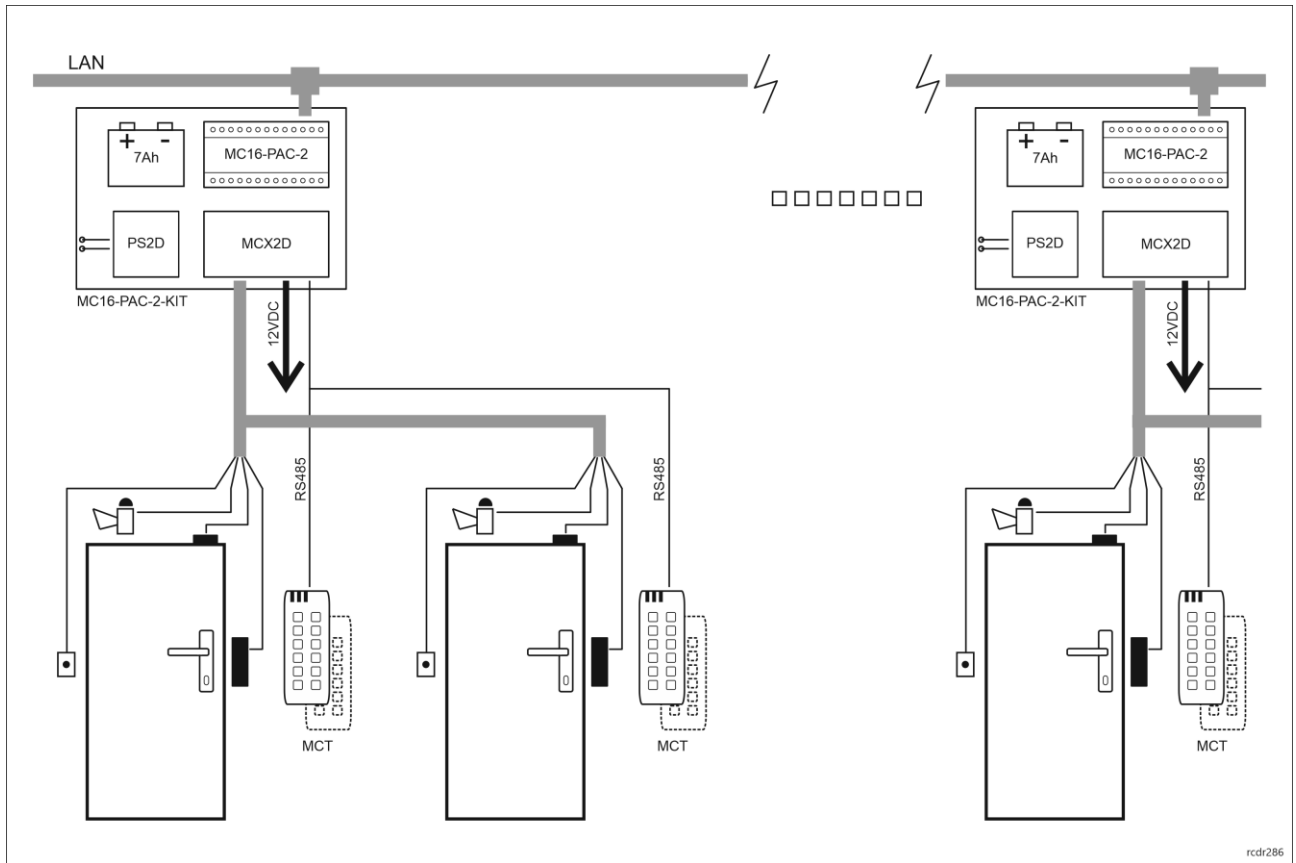

Fig. 4 Scenario of operation with MC16-PAC-2-KITs

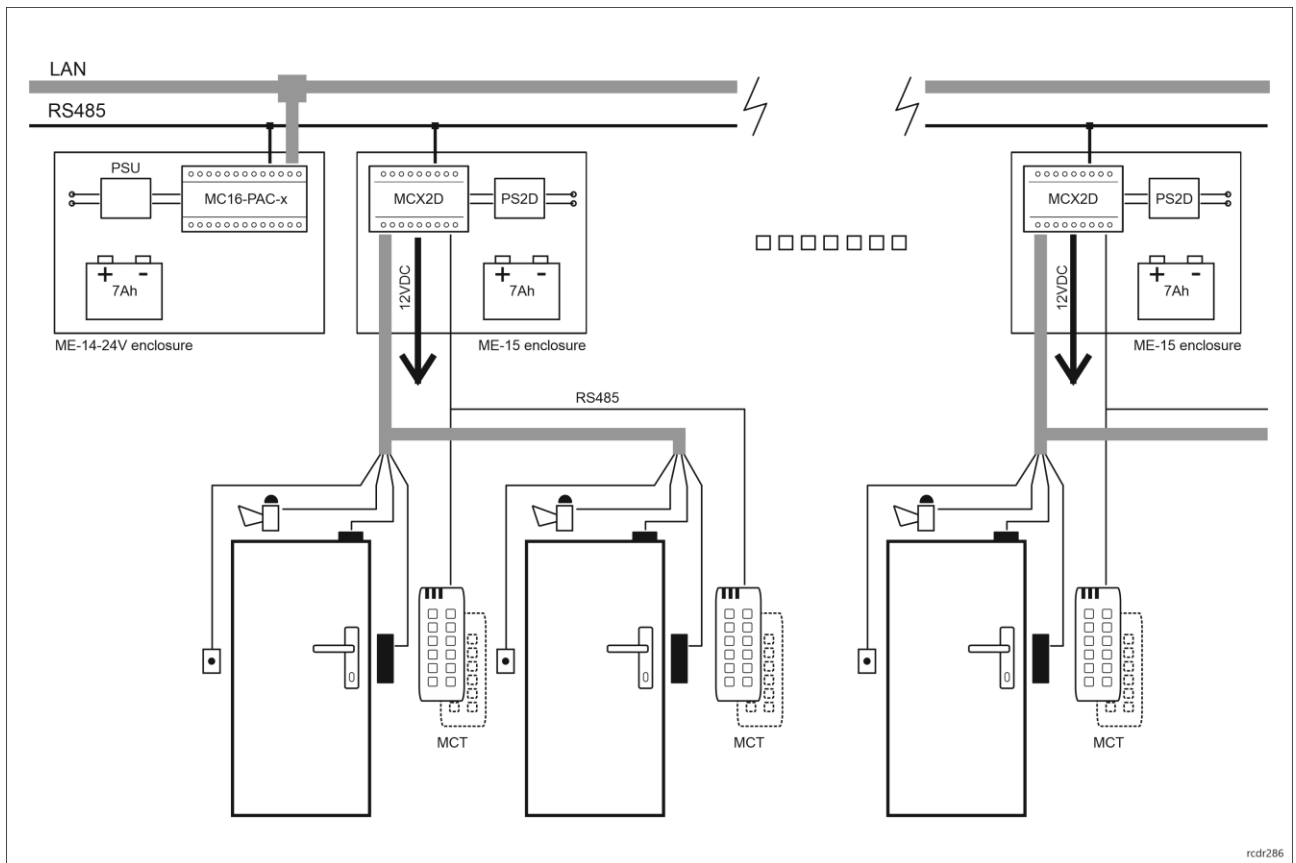

Fig. 5 Scenario of operation with multiple MCX2D expanders

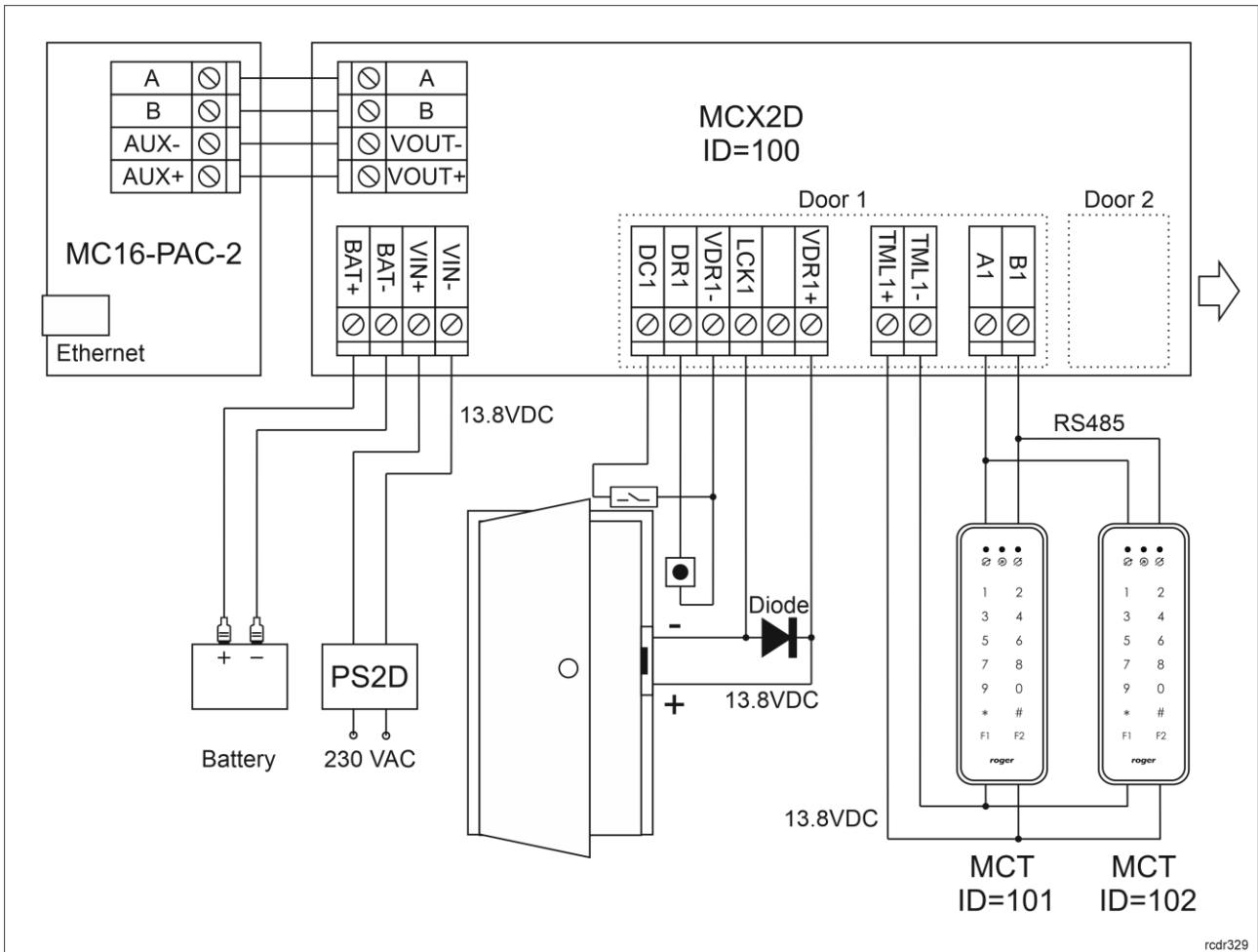

Fig. 6 Connection diagram for MCX2D expander in MC16-PAC-2-KIT

4. CONFIGURATION

The purpose of low level configuration is to prepare device for operation in RACS 5 system. In case of RACS 5 v1 system the address of device must be configured by means of RogerVDM software or by manual addressing before connection to MC16 controller. While in RACS v2 system, low level configuration and addressing can be done with VISO v2 software during final configuration of the system. Therefore in RACS 5 v2 system the configuration from RogerVDM software and manual addressing are optional and during installation it is only necessary to properly connect the device to MC16 access controller.

Low level configuration (VISO v2)

In RACS 5 v2 system the expander can be installed at site without previous configuration. According to AN006 application note, its address and other settings can be configured from VISO v2 management software and during such configuration the access to its service contacts (fig. 2) is not required.

Low level configuration (RogerVDM)

The purpose of low level configuration is to prepare device for operation in RACS 5 system.

Programming procedure with RogerVDM software (firmware 1.1.30.266 or newer):

1. Connect the device to RUD-1 interface (fig. 7) and connect the RUD-1 to computer's USB port.
2. Remove jumper from MEM contacts (fig. 2) if it is placed there.
3. Restart the device by pressing RST button and RUN LED indicator will pulsate. Then within 5 seconds place jumper on MEM contacts and RUN LED indicator will pulsate quicker.
4. Start RogerVDM program, select MCX v1.x device, v1.x firmware version, RS485 communication channel and serial port with RUD-1 interface.

5. Click *Connect*, the program will establish connection and will automatically display *Configuration* tab.
6. Enter unoccupied RS485 address in range of 100-115 (if necessary) and other settings according to requirements of specific installation.
7. Click *Send to Device* to update the configuration.
8. Optionally make a backup by clicking *Send to File...* and saving settings to file on disk.
9. Disconnect from RUD-1 interface and leave jumper on MEM contacts to enable further configuration of device from VISO v2 software or remove jumper from MEM contacts to block such remote configuration.

Programming procedure with RogerVDM software (firmware older than 1.1.30.266):

1. Connect the device to RUD-1 interface (fig. 7) and connect the RUD-1 to computer's USB port.
2. Place jumper on MEM contacts (fig. 2).
3. Restart the device by pressing RST button and RUN LED indicator will pulsate.
4. Start RogerVDM program, select *MCX v1.x* device, *v1.x* firmware version, *RS485* communication channel and serial port with RUD-1 interface.
5. Click *Connect*, the program will establish connection and will automatically display *Configuration* tab.
6. Enter unoccupied RS485 address in range of 100-115 (if necessary) and other settings according to requirements of specific installation.
7. Click *Send to Device* to update the configuration.
8. Optionally make a backup by clicking *Send to File...* and saving settings to file on disk.
9. Remove jumper from MEM contacts and disconnect device from RUD-1 interface.

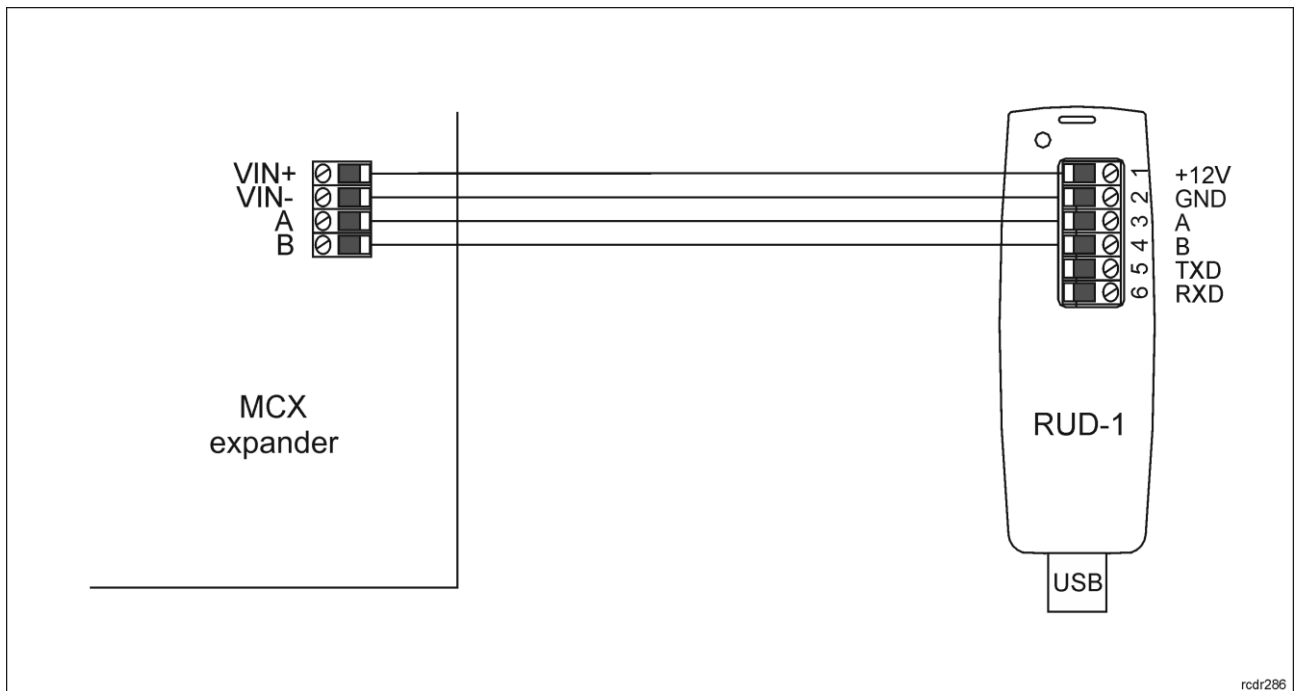

Fig. 7 Connection to RUD-1 interface (low level configuration)

Table 4. List of low level parameters	
Communication settings	
RS485 address	Parameter defines device address on RS485 bus. Range: 100-115. Default value: 100.
RS485 communication timeout [s]	Parameter defines delay after which device will signal lost communication with controller. When set to 0 then signalling is disabled. Range: 0-64s. Default value: 20s.
RS485 encryption	Parameter enables encryption at RS485 bus. Range: [0]: No, [1]: Yes. Default value: [0]: No.
RS485 encryption key	Parameter defines key for encryption of communication at RS485 bus. Range: 4-16 ASCII characters.

Input types	
DC1, DR1, DC2, DR2	Parameter defines input type. Range: [1]: NO, [2]: NC, [3]: EOL/NO, [4]: EOL/NC, [5]: 2EOL/NO, [6]: 2EOL/NC, [7]: 3EOL/NO, [8]: 3EOL/NC, [9]: 3EOL/DW/NO, [10]: 3EOL/DW/NC. Default value for DC is [2]: NC. Default value for DR is [1]: NO.
Parametric (EOL) input resistances	
Tamper, Alarm A, Alarm B [Ohm]	Parameter defines resistor for parametric (EOL) inputs.
Input response times	
DC1, DR1, DC2, DR2 [ms]	Parameter defines minimal duration of pulse which is required to trigger the input. Range: 50-5000. Default value: 50.
Output polarity	
LCK1, BELL1, LCK2, BELL2	Parameter defines polarity of output. Normal polarity means that the output by default is switched off while Reversed polarity means that the output by default is switched on. Range: [0]: Normal polarity, [1]: Reversed polarity. Default value: [0]: Normal polarity.
Comments	
DEV, PWR	Parameter defines any text or comment which corresponds to the device/object. It is later displayed in VISO program.
Input comments	
DC1, DR1, DC2, DR2	Parameter defines any text or comment which corresponds to the object. It is later displayed in VISO program.
Output comments	
LCK1, BELL1, LCK2, BELL2	Parameter defines any text or comment which corresponds to the object. It is later displayed in VISO program.

Memory reset and manual addressing

Memory reset procedure resets all settings to factory default ones and it enables to manually configure the address on RS485 bus.

Memory reset and manual addressing procedure (firmware 1.1.30.266 or newer):

1. Remove all connections from LCK1 and DC1 lines.
2. Remove jumper from MEM contacts (fig. 2) if it is placed there.
3. Connect LCK1 and DC1 lines.
4. Restart the device by pressing RST button and RUN LED indicator will pulsate. Then within 5 seconds place jumper on MEM contacts and ACL LED indicator will pulsate.
5. Disconnect LCK1 and DC1 lines and RUN LED indicator will pulsate slowly. The number of consecutive flashes will correspond to expander's address on RS485 bus.
6. Press RST button in a certain moment to define certain address (table 1) or press RST button after 16 flashes when ACL and RUN LED indicators are switched on to define default ID=100 address.
7. Disconnect from RUD-1 interface and leave jumper on MEM contacts to enable further configuration of device from VISO v2 software or remove jumper from MEM contacts to block such remote configuration.

Memory reset and manual addressing procedure (firmware older than 1.1.30.266):

1. Remove all connections from LCK1 and DC1 lines.
2. Place jumper on MEM contacts (fig. 2).
3. Connect LCK1 and DC1 lines.
4. Restart the device by pressing RST button and ACL LED indicator will pulsate.
5. Disconnect LCK1 and DC1 lines and RUN LED indicator will pulsate. The number of consecutive flashes will correspond to expander's address on RS485 bus.

6. Press RST button in a certain moment to define certain address (table 5) or press RST button after 16 flashes when ACL and RUN LED indicators are switched on to define default ID=100 address.
7. Remove jumper from MEM contacts and restart the device.

Number of RUN LED flashes	RS485 address	Number of RUN LED flashes	RS485 address
1	101	9	109
2	102	10	110
3	103	11	111
4	104	12	112
5	105	13	113
6	106	14	114
7	107	15	115
8	108	16	100

Example:

In order to select ID=105 address within memory reset procedure, press RST button after 5 flashes of RUN LED indicator.

High level configuration (VISO)

The purpose of high level configuration is to define logical functioning of the expander which communicates with the MC16 access controller and it depends on applied scenario of operation. The example of access control system configuration is given in AN006 application note which is available at www.roger.pl.

5. FIRMWARE UPDATE

The firmware of device can be changed to newer or older version. The update requires connection to computer with RUD-1 interface (fig. 2) and starting RogerVDM software. The latest firmware file is available at www.roger.pl.

Firmware update procedure:

8. Connect the device to RUD-1 interface (fig. 8) and connect the RUD-1 to computer's USB port.
9. Place jumper on FDM contacts (fig. 2).
10. Restart the device by pressing RST button and TXD LED indicator will switch on.
11. Start RogerVDM program and in the top menu select *Tools* and then *Update firmware*.
12. In the opened window select device type, serial port with RUD-1 interface and path to firmware file (*.hex).
13. Click *Update* to start firmware upload with progress bar in the bottom.
14. When the update is finished, remove FDM jumper and restart the device. Additionally it is recommended to start memory reset procedure.

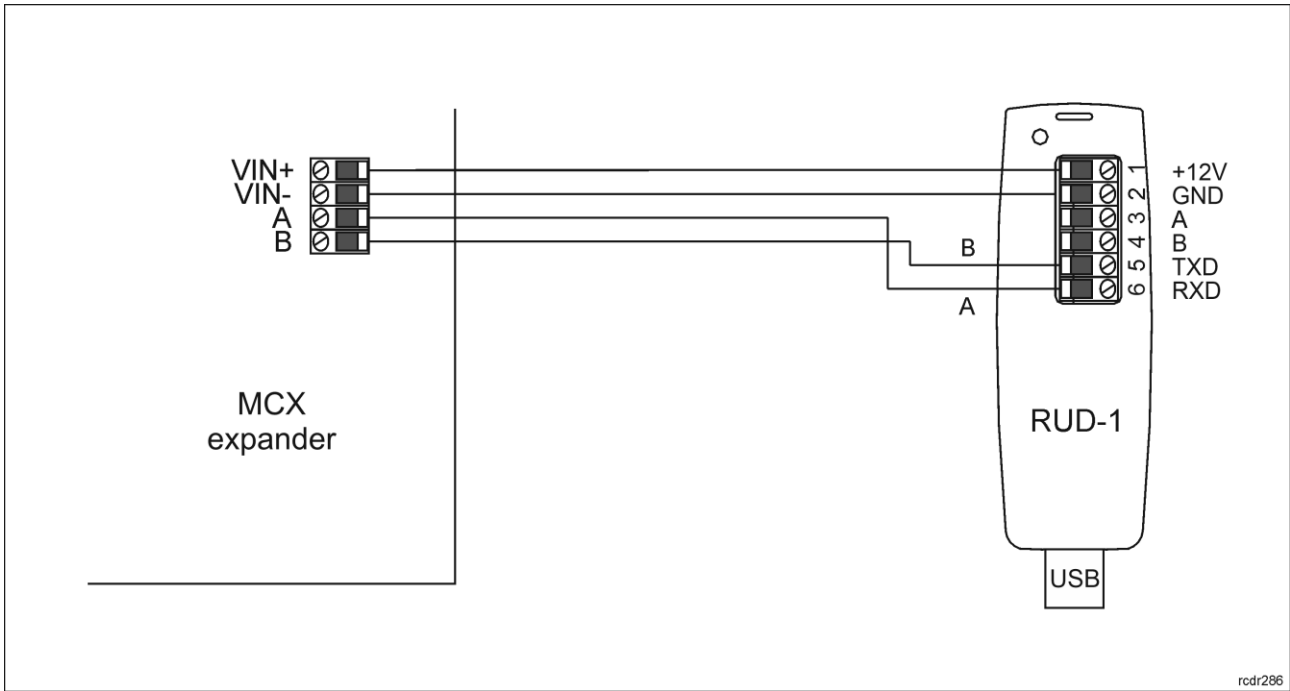

Fig. 8 Connection to RUD-1 interface (firmware update)

6. SPECIFICATION

Table 6. Specification	
Nominal supply voltage	13.8VDC; +/- 100mV (with battery support) or 12.0VDC (without battery support)
Nominal current consumption	50mA (expander module) + battery charging current + outputs (VOUT, AUX, TML, VDR)
Battery charging current	Configurable: ~0.3A/0.6A/0.9A
Inputs	Four (DCx, DRx) parametric inputs
Transistor outputs	Four (LCKx, BELLx) outputs, each with 15V/1.0A DC max load
Power supply outputs	VOUT, AUX: 0.2A TML1-2: 0.2A VDR1-2: 1.0A Note: The voltage level on output is equal to expander supply voltage
Distances	Up to 1200 m between MC16 controller and MCX expander (RS485). Up to 1200 m between MCX expander and MCT terminals (RS485) The total distance between controller and any terminal cannot exceed 1200m.
Environment	Indoor general conditions, temperature: +5°C to +40°C, relative humidity: 10 to 75% (no condensation)
Dimensions W x S x G	80 x 80 x 20 mm
Weight	65 g
Compliance	CE, RoHS

7. ORDERING INFORMATION

Table 7. Ordering information	
MCX2D	MCX2D expander electronic module for installation in a metal housing with a

	power supply
MC16-PAC-2-KIT	2-door access control kit; ME-15 metal enclosure; MC16-PAC-2 access controller module; MCX2D I/O expander; PS2D power supply
RUD-1	Portable USB-RS485 communication interface dedicated to ROGER access control devices

8. PRODUCT HISTORY

Table 8. Product history		
Version	Date	Description
MCX2D v1.0	10/2017	The first commercial version of product

	<p>This symbol placed on a product or packaging indicates that the product should not be disposed of with other wastes as this may have a negative impact on the environment and health. The user is obliged to deliver equipment to the designated collection points of electric and electronic waste. For detailed information on recycling, contact your local authorities, waste disposal company or point of purchase. Separate collection and recycling of this type of waste contributes to the protection of the natural resources and is safe to health and the environment. Weight of the equipment is specified in the document.</p>
---	---

Contact:

Roger sp. z o.o. sp.k.
82-400 Sztum
Gościszewo 59
Tel.: +48 55 272 0132
Fax: +48 55 272 0133
Tech. support: +48 55 267 0126
E-mail: support@roger.pl
Web: www.roger.pl