

Roger Access Control System

XM-8DR I/O expander

Operating Manual

Firmware version: 1.0

Hardware version: 1.0

Document version: Rev. D



1. DESCRIPTION AND SPECIFICATION

The XM-8DR is I/O expander with 8 NO/NC input lines and 8 relay outputs with single NO/NC contact each. The module is addressable and it is dedicated to devices with RACS Clock&Data interface, namely RACS 4 controllers.

Optionally, XM-8DR can be used as standalone device (without communication with master device) and then its outputs are controlled by means of voltage signals at respective inputs. Currently the expander is available only as electronic module without enclosure and it is designated as XM-8DR-BRD. With expander there are included adapters, which can be used for XM-8DR-BRD installation on DIN 35 mm rail.

Table 1. Specification	
Parameter	Description
Supply voltage	Nominal 12 VDC, min./max. 10-15VDC
Current consumption	25mA plus 40mA per each activated relay
Relay max load	30VDC/1.5A
Input lines	NO/NC inputs, electrically biased to +12V via 5.6kΩ resistor, triggering level approx. 3 V
Distance	Between controller and XM-8DR-BRD expander: max. 150 m
Environmental class (according to EN 50131-1)	Class IV, -25C..+60C, relative humidity: 10 to 95% (no condensation), indoor conditions
Dimensions (HxW)	72x155 mm
Weight	115g
Certificates	CE

2. INSTALLATION

2.1 Terminals and connection diagram

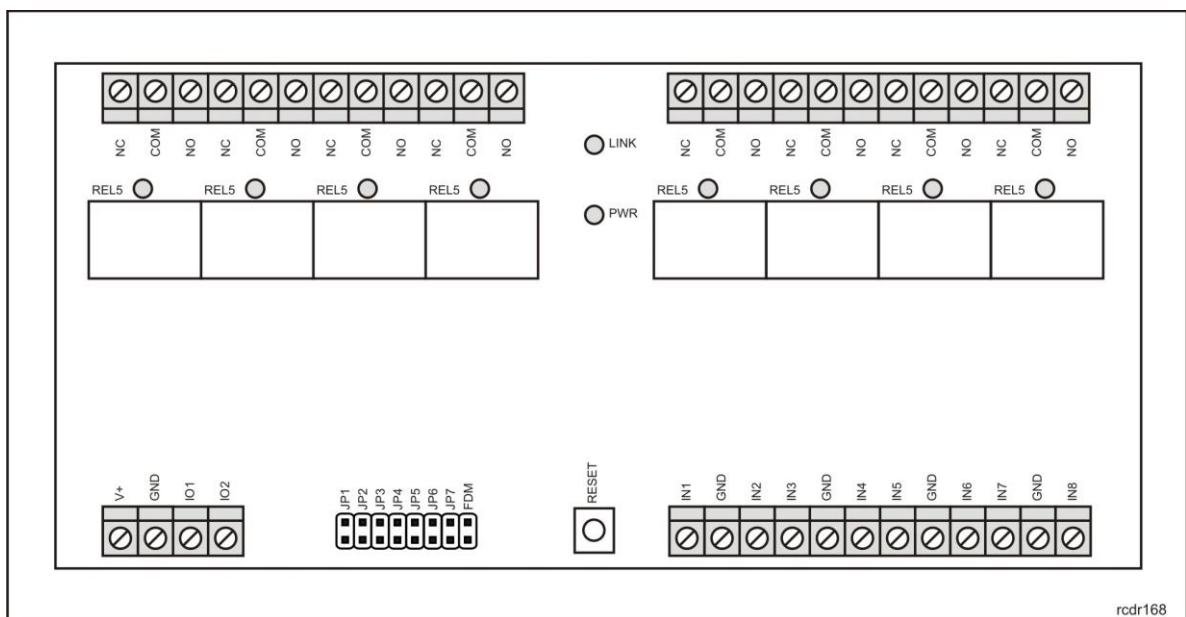

Fig. 1 XM-8DR-BRD I/O expander

Table 2. XM-8DR-BRD terminals	
Terminal	Function
+12V	Positive power supply contact, 12V DC
GND	Ground
IO1	RACS Clock&Data comm. bus (CLK terminal)
IO2	RACS Clock&Data comm. bus (DTA terminal)
IN1-IN8	Input lines
NO	Relay output (NO)
COM	Relay common terminal
NC	Relay output (NC)

In the fig. 2 there is shown connection diagram for XM-8DR and PR402DR access controller. The communication is performed by means of RACS Clock&Data bus.

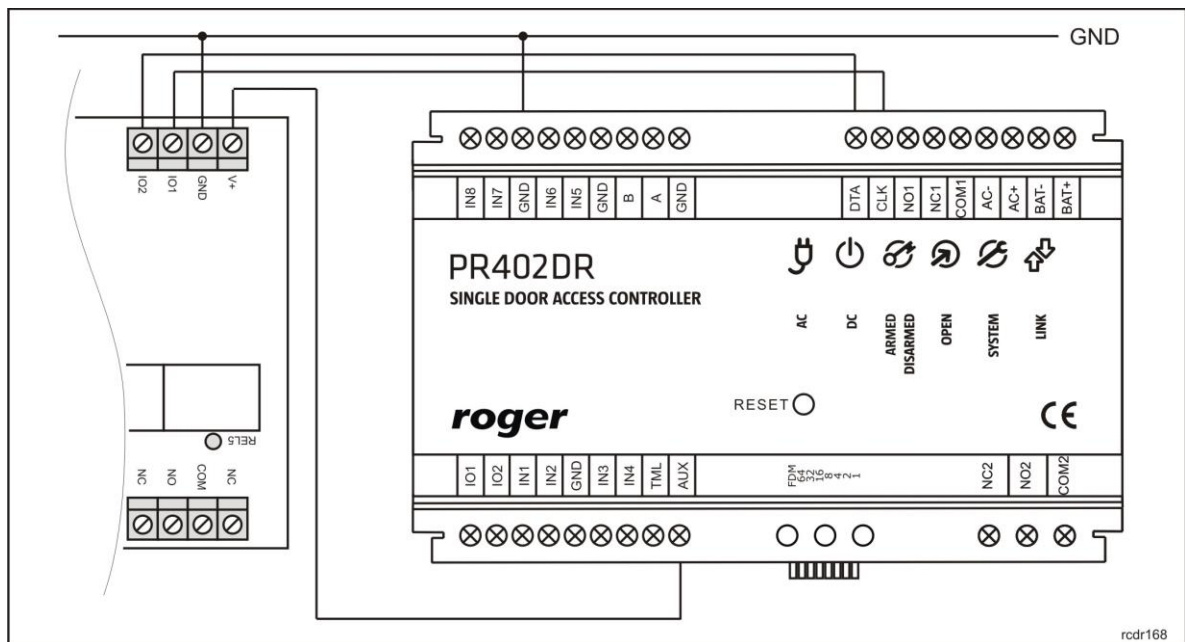

Fig. 2 Connection of XM-8DR-BRD expander with PR402DR controller

2.2. LED indicators

XM-8DR is equipped with ten LED indicators i.e. LED Link, LED Power and 8 indicators associated with relays. When LED indicator at REL1..REL8 inscription is on then corresponding relay is activated. LED Link signals the communication between expander and master device (controller) while LED Power can signal 4 states according to table. 3.

Table 3. LED Power signalling	
State	Description
Steady light	Normal operation
Infrequently flashing light (2Hz)	No communication
Frequently flashing light (10Hz)	Too low supply voltage

Two short pulses every 2 seconds	Microcontroller memory failure. In such case it is necessary to upload firmware or repair the expander.
----------------------------------	---

2.3 Power supply

The XM-8DR requires 12VDC nominal power supply. If the voltage is below ~10V then the module stops its operation, deactivates all relays and signals the error by means of LED Power indicator (blinks 10 times per second).

Note: For proper communication by means of RACS Clock& Data bus it is required to connect all GND terminals of devices. Such requirement is satisfied if both devices are supplied from the same point. If devices are supplied from different power supply units then GND terminals of communicating devices must be connected by means of separate wire in order to equalize potentials. Any wire section can be applied.

2.4 Module mounting

XM-8DR-BRD module is not adapted to outdoor operation and it is installer responsibility to apply proper method and location for module installation. The module is accompanied with two adapters for installation on DIN 35mm rail. Optionally, XM-8DR-BRD can also be installed on flat surface by means of included nylon studs.

Note: For proper operation of XM-8DR with PRxx2 series access controllers it is necessary to put jumper on contacts JP6 in order to maintain compatibility with previous versions of XM-8.

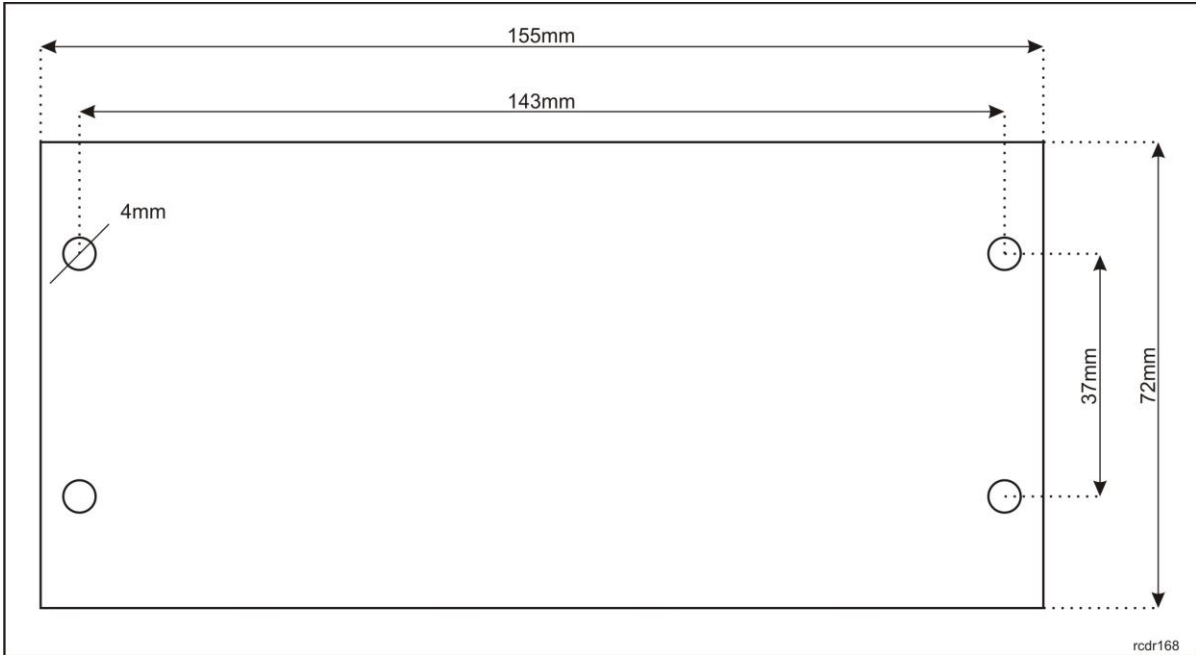

Fig. 3 Mounting holes in XM-8DR-BRD board

3. CONFIGURATION

3.1 Expander configuration

The configuration of XM-8DR-BRD is performed by means of jumpers according to table 4.

Table 4. Configuration jumpers	
Jumper	Function
JP1	Address jumper „1“
JP2	Address jumper „2“
JP3	Address jumper „4“
JP4	Address jumper „8“
JP5	No function
JP6	Disabling communication failure signalling (compatibility with XM-8-BRD)
JP7	Selection of operating mode: standalone/network
FDM	Firmware download mode

Note: Every time a jumper is put or removed it is necessary to restart the module in order to make new settings effective. The restart can be done by means of RESET button or power supply switch off and on.

The address of XM-8DR can be programmed by means of jumpers based on their values e.g. jumpers on pins JP1 and JP3 signify the address ID=5 ($1+4 = 5$) while jumpers on all JP1...JP4 pins signify ID=15 ($1+2+4+8 = 15$).

Jumper JP6 is used for ensuring compatibility with previous versions of XM-8 module and it is necessary to put jumper JP6 if XM-8DR is to operate with PRxx2 series controller (RACS 4). JP7 pins can be used for selection of operation mode. If the jumper is on JP7 then XM-8DR operates in standalone mode and then its relay outputs can be activated by electric signal at corresponding inputs i.e. IN1 -> REL1 and IN2 -> REL2. If there is no jumper on JP7 pins then XM-8DR operates in normal mode RACS Clock & Data protocol.

Note: In case of network operating mode i.e. communication with PR series controller, it is necessary to set XM-8DR address in range ID=8...11.

3.2 Access control in elevators

All versions of XM-8 expander can be used in elevator access control. In the figure below there is shown typical connection diagram of PRxx2 series controller, XM-8DR module and elevator control panel.

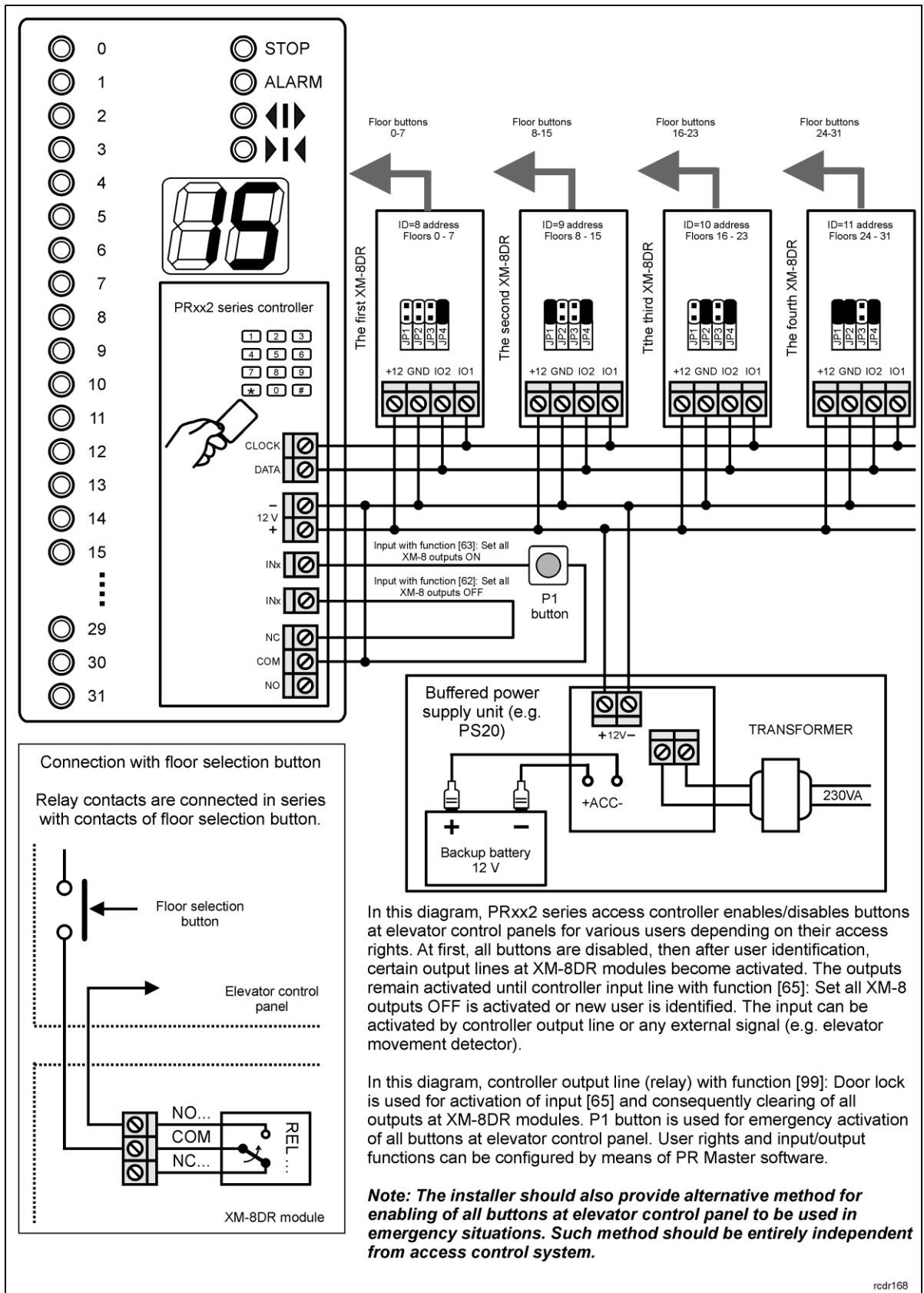

Fig. 4 XM-8DR module in elevator access control

3.3. Firmware update

Roger devices are always delivered with the latest version of firmware but it can be updated by customer. The latest version of firmware, which might offer new functionalities and/or eliminate errors is available at www.roger.pl. New firmware can be uploaded to XM-8DR by means of computer z with RogerISP software (ver. 5 or newer) and it requires communication interface device e.g. RUD-1 connected to USB port of the computer.

Firmware update procedure

- Place jumper on FDM pins
- Connect XM-8DR to RUD-1 in accordance with table 5
- Reset the device (use RESET button or switch power supply off/on)
- Start RogerISP software and select communication port
- In Firmware window select firmware *.hex file
- Click Program button
- After firmware upload, remove jumper from FDM pins and reset the device (use RESET button or switch power supply off/on)
- Disconnect XM-8DR from RUD-1



XM-8DR terminal	RUD-1 terminal
+12V	1
GND	2
IO1	5
IO2	6

4. ORDERING INFORMATION

Product	Description
XM-8DR-BRD	Input/output addressable expander, electronic module without enclosure

5. PRODUCT HISTORY

Version	Firmware	Date	Description
XM-8DR v1.0	1.0	06/2012	The first commercial version of the product

 	<p>This symbol placed on a product or packaging indicates that the product should not be disposed of with other wastes as this may have a negative impact on the environment and health. The user is obliged to deliver equipment to the designated collection points of electric and electronic waste. For detailed information on recycling, contact your local authorities, waste disposal company or point of purchase. Separate collection and recycling of this type of waste contributes to the protection of the natural resources and is safe to health and the environment. Weight of the equipment is specified in the document.</p>
--	---

Contact:
ROGER sp. z o.o. sp. k.
82-400 Sztum
Gościszewo 59
Tel.: +48 55 272 0132
Fax: +48 55 272 0133
Tech. support: +48 55 267 0126
E-mail: biuro@roger.pl
Web: www.roger.pl