

Roger Access Control System

User manual for UT-4DR communication interface

Firmware version: 1.0.6 or newer

Hardware version: 1.0

Document version: Rev. H

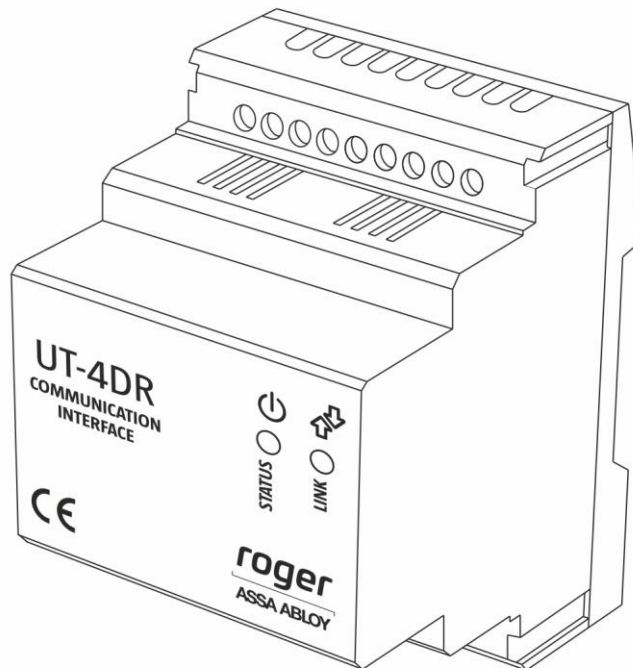

Contents

1. Introduction	3
1.1 This manual	3
2. Description and specification	3
3. Installation	4
3.1 Terminals and connection diagram	4
3.2 Front panel	4
3.3 Power supply	5
3.4 Communication with interface	5
3.5 Communication of interface with controllers	5
3.6 Input and output lines	6
3.7 Installation guidelines	6
4. Configuration.....	6
4.1 Configuration with web browser	6
4.2 Configuration with PR Master software	8
4.3 Configuration with Telnet.....	9
4.4 Time synchronisation.....	10
4.5 Memory Reset.....	10
4.6 Firmware update	11
5. Ordering information.....	11
6. Product history	11

1. INTRODUCTION

1.1 This manual

This manual contains minimum information that is necessary to properly install UT-4DR communication interface within RACS 4 access control system and in other applications. Full functional description of RACS 4 system and PR Master software is specified in following documents which are available at www.roger.pl:

- Functional description of PRxx2 series controllers
- Functional description of PRxx1 series controllers
- PR Master User manual

2. DESCRIPTION AND SPECIFICATION

UT-4DR is Ethernet - RS485 interface enabling communication with PR series controllers of RACS 4 access control system through computer network. Additionally the interface is equipped with 4 universal Input/Output lines which can be managed using web browser or by means of Telnet protocol. This feature gives possibility to use the device in other applications beyond RACS 4 system as a remote I/O port managed through computer network. UT-4DR interface requires 12VDC power supply and is installed in plastic enclosure dedicated to mounting on standard DIN 35mm rail.

Note: In case of use in RACS 4 system, the UT-4DR requires PR Master software in version 4.4.6 or newer.

Note: It is not possible to use UT-4DR interface as a virtual serial port so it cannot be used for firmware upgrade of PR series controllers connected to RS485 bus.

Note: It is not recommended to use UT-4DR interface for communication with discontinued PR201 and PR301 access controllers.

Table 1. Specification	
Supply voltage	Nominal 12VDC, min./max. range 10-15VDC
Average current consumption	55 mA
Inputs/Outputs	Four (IO1...IO4) NO inputs, electrically biased to +12V via 5,6kΩ resistor, triggering level approx. 3.5V which can be configured as four open collector outputs with 15VDC/500mA max. load
Ethernet port	10BASE-T 10/100Mb communication port
Distances	Between UT-4DR and controller (RS485): max. 1200m
Environmental class (acc. to EN 50131-1)	Class I, indoor general conditions, temperature: +5°C to +40°C, relative humidity: 10 to 95% (no condensation)
IP code	IP41
Dimensions H x W x D	62 x 85 x 73mm
Weight	approx. 110g
Certificates	CE, RoHS

3. INSTALLATION

3.1 Terminals and connection diagram

Table 2. UT-4DR terminals			
Terminal	Description	Terminal	Description
IO1	IO1 input/output line	B	RS485 communication bus
IO2	IO2 input/output line	A	RS485 communication bus
IO3	IO3 input/output line	GND	Ground
IO4	IO4 input/output line	+12V	12VDC power supply
GND	Ground		

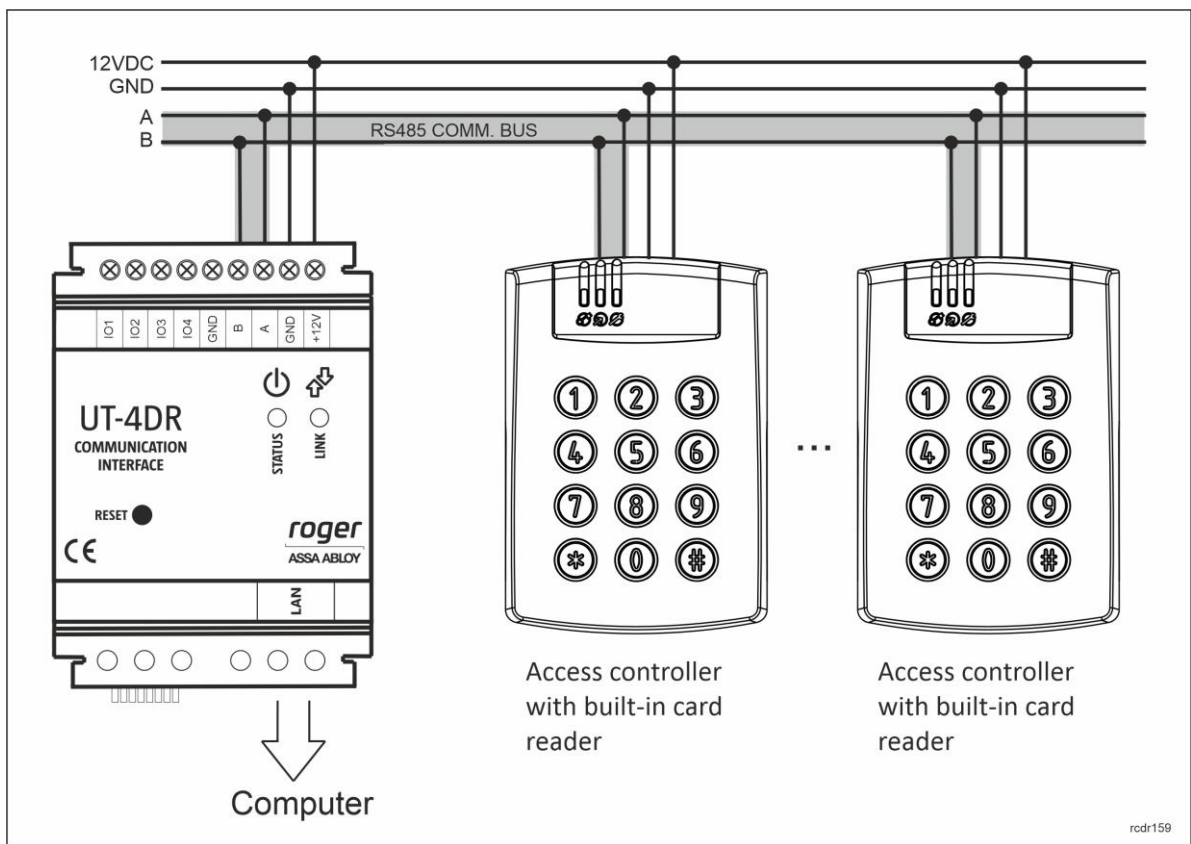

Fig.1 Typical connection diagram for UT-4DR interface

3.2 Front panel

According to fig. 2, the UT-4DR interface is equipped with LED indicators on front panel to indicate various states of the device and with RESET button to restart the controller in the same way as in case of powering device off and then on. The RESET button can also be used during Memory Reset procedure and during firmware update procedure.

Table 3. UT-4DR front panel	
LINK	Data transmission on RS485 bus

STATUS	Various signalling functions: <ul style="list-style-type: none"> • steady light – normal device operation • flashing light – configuration error; full memory reset and successive device configuration is necessary • no light – Ethernet communication error
--------	---

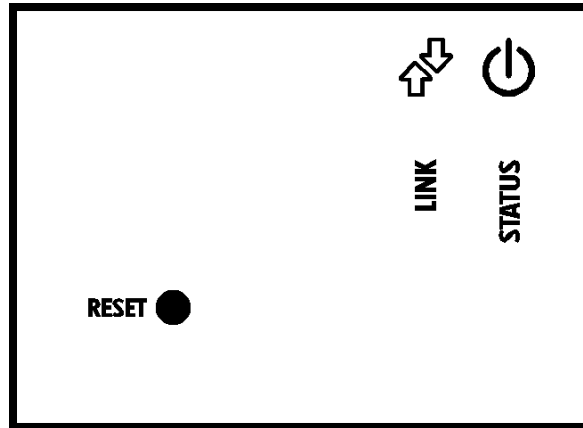

rodr159

Fig. 2 UT-4DR front panel

3.3 Power supply

UT-4DR interface requires 12VDC nominal power supply. The power should be connected to the 12V line and GND line. Additionally, the GND line can be used as reference potential for the RS485 bus and IO1..IO4 input lines. The power supply can be provided by means of power supply unit (e.g. PS-15DR, PS20) which can be equipped with backup battery in order to ensure operation of the interface in case of power failure.

Note: All devices connected to RS485 bus (including controllers) should have the same supply minus (GND). In order to ensure this, all the GND terminals from various power supply units within the system should be connected with each other using separate wire. Alternatively, the common supply minus of the entire system can be earthed however only in one point.

3.4 Communication with interface

UT-4DR is equipped with 10BaseT Ethernet port which is used for communication with computer and other devices/systems in LAN/WAN computer network.

Note: The operation of UT-4DR in dedicated LAN is guaranteed by Roger. Practical tests proved that the interface can be also used in LAN, where multiple systems are operated as well as in WAN but in such case UT-4DR functioning is not guaranteed by Roger due to number of possible and unpredictable network conditions.

3.5 Communication of interface with controllers

UT-4DR is equipped with RS485 communication port which is used for communication with PR series controllers. The RS485 bus consists of two signal lines A and B. In the RACS 4 system any topology can be used (star, tree or any combination of them, except for loop) in order to connect controllers in network (subsystem). The matching resistors (terminators) connected at the ends of transmitting lines are not required. In most cases communication works with any cable type (standard telephone cable, shielded or unshielded twisted pair etc.) but the recommended cable is unshielded twisted pair (U/UTP cat.5). Shielded cables should be limited to installations subject to strong electromagnetic interferences. The RS485 communication standard used in the RACS 4

system guarantees proper communication in a distance of up to 1200 meters as well as high resistance to interferences.

3.6 Input and output lines

UT-4DR is equipped with four IO1..IO4 general purpose lines which can be configured individually as independent inputs or outputs. Each line can work with maximal voltage of 15VDC (in reference to device's power supply ground) both when operated as input or output. Input lines are triggered by shorting them to ground (NO lines). Output lines in normal state represent high impedance while in triggered state they short to ground. Maximal current switched by output lines is limited to 0.5A. If this value is exceeded, an internal overload protection is activated and then all output lines are switched off until the overload problem is resolved. In overload state UT-4DR stops its normal operation.

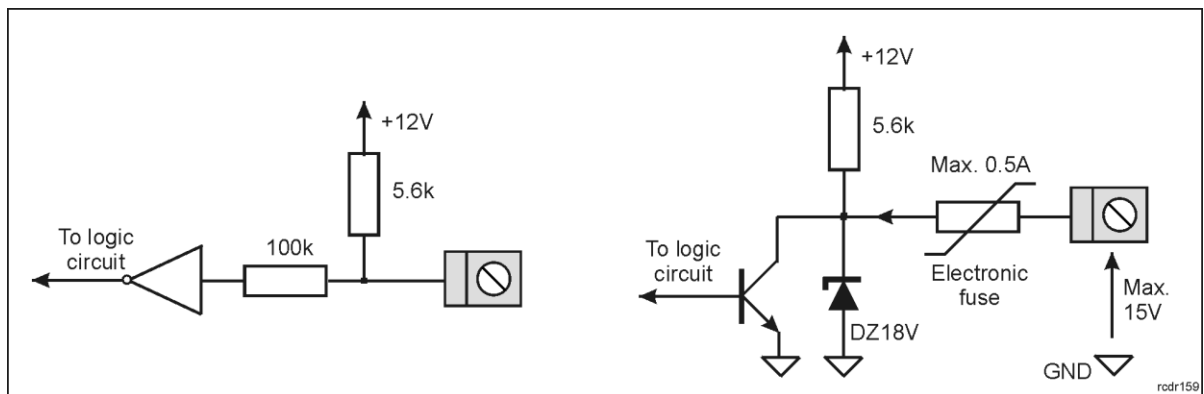

Fig.3 Electrical structure of UT-4DR input (left) and output (right)

3.7 Installation guidelines

- Install devices in such way as to ensure easy access to screw terminals, jumpers and RST button of the interface.
- All electric connections must be made with power supply switched off.
- All devices connected to the same communication bus (RS485) should be connected to the same negative potential (GND). Therefore all GND terminals from various power supply units used in the system should be connected with each other.

4. CONFIGURATION

4.1 Configuration with web browser

In order to communicate with UT-4DR interface it is necessary to know its IP address and port. Default parameters of the interface are as follows:

IP address=192.168.0.38
 Subnet mask=255.255.255.0
 Default gateway=192.168.0.1
 Administrator login: root
 Administrator password: dbps
 TCP port = 2101

It is assumed that mentioned above parameters will be changed in particular access control installation, specifically IP address and administrator password. These parameters can be modified by means of UT-4DR webpage opened with web browser.

Note: In order to connect with UT-4DR in local area network (LAN), the computer must be in the same subnet. In case of UT-4DR with default IP address, the IP address of computer should be 192.168.0.xxx.

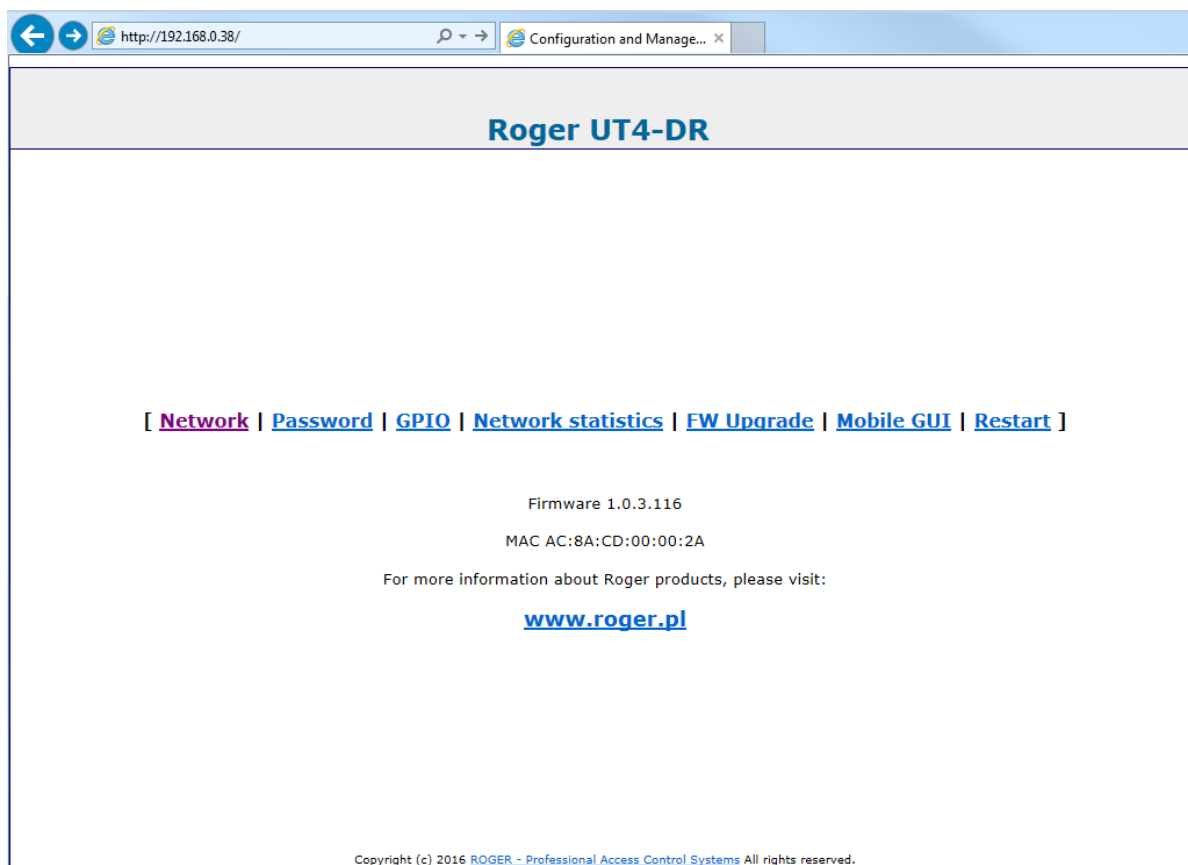

Fig. 4 UT-4DR webpage in web browser

Following options are available on UT-4DR web page:

Network

In this window such parameters of UT-4DR can be modified:

- IP address
- subnet mask
- TCP port
- NTP server
- UTC zone

Note: DHCP functionality was disabled in firmware version 1.0.4

Password

In this window administrator password can be modified.

GPIO

In this window IO1..IO4 general purpose lines can be configured as inputs or outputs and then input status can be monitored as well as outputs can be remotely activated. Input status can be refreshed manually or automatically (periodically).

Network Statistics

In this window some statistics regarding connection with UT-4DR and NTP synchronization are available.

FW Upgrade

In this window UT-4DR firmware can be upgraded. More information is given in section 4.6 Firmware update

Mobile GUI

In this window it is possible to switch from standard graphical user interface to the interface designed for mobile devices.

Restart

In this window UT-4DR can be restarted remotely.

4.2 Configuration with PR Master software

After connection of UT-4DR to access controllers within RACS 4 system and to computer in LAN/WAN, the installer can proceed with installation and configuration of PR Master software. UT-4DR acts as Ethernet-RS485 communication interface with access controllers.

In order to create new subsystem with UT-4DR unit and to detect access controllers, it is necessary to select the option **Networks** in the main window of PR Master software and then click the button **Add network**. In the newly opened window (see fig. 5) in the field **Communication port** select **UT-4DR**, in the field **Server IP** enter IP address of UT-4DR and in the field **Server Port** enter TCP port of UT-4DR. Additionally in the field **Interface** it is possible to select if the interface is operated in LAN or WAN which results in different levels of acceptable communication delays. If **Custom** option is selected then communication delay can be specified manually.

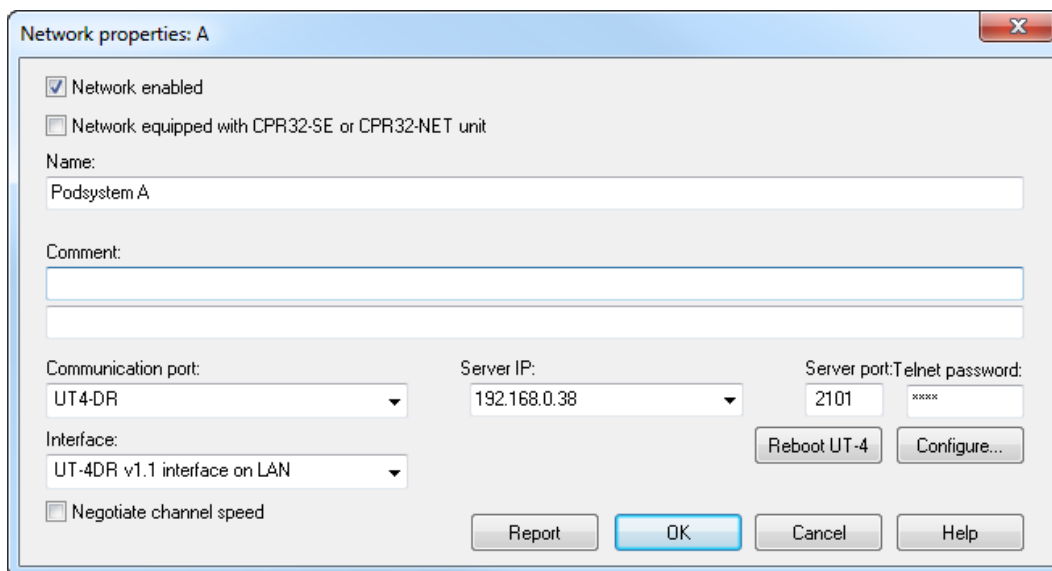

Fig. 5 Network properties windows

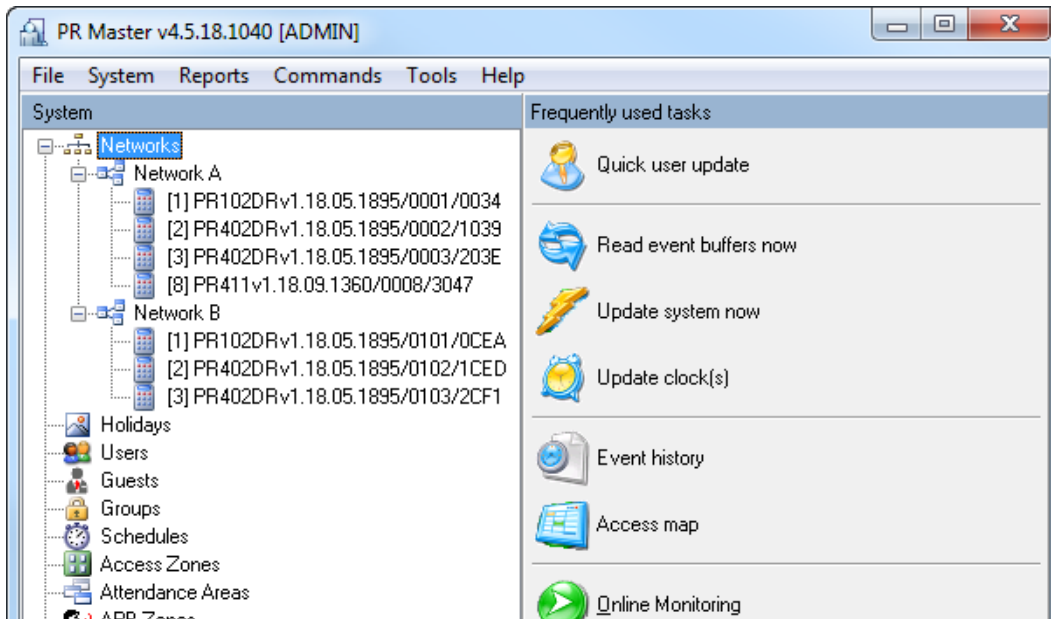

Fig. 6 Main window of PR Master software

In the next step close the window by means of **OK** button and in the **Network properties** window click the button **Controllers**. In the newly opened window click the button **Add** in order to detect all controllers connected to RS485 bus. The maximum number of PR series access controllers connected to UT-4DR equals to 32 units and each controller connected to RS485 bus must have unique address. Example of RACS 4 system is shown in fig. 6. Multiple UT-4DR interfaces each in individual RS485 network (subsystem) can operate within single RACS 4 system. Each UT-4DR interface must have individual IP address but they can use the same TCP port.

4.3 Configuration with Telnet

In order to log in to the UT-4DR, please type in the command line: telnet <device IP address>, e.g. telnet 192.168.0.38. Then please log in as a default user (user: root, password: dbps). Then after entering **help** command, a list of available commands shall be displayed.

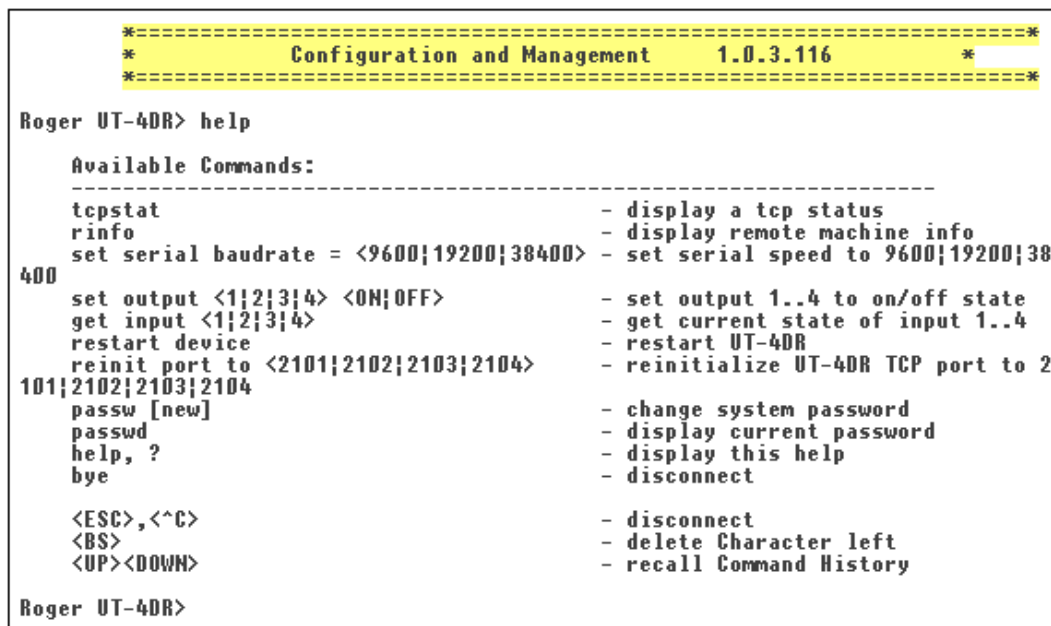

Fig.7 Configuration with Telnet

Note: Procedure of connection with UT-4DR interface using Telnet protocol may vary depending on used Telnet client application. In Windows Vista or newer Telnet client is disabled by default and it has to be enabled prior to connection with UT-4DR.

4.4 Time synchronisation

UT4-DR interface can synchronize time of devices connected to its RS485 bus using selected NTP server. Parameters of NTP server including time zone and daylight saving time can be configured in **Network** tab during the configuration of the interface with web browser. When server address is empty then suggested default address can be selected from the list. The latest synchronization is logged in **Network Statistics** tab.

The interface synchronizes time with NTP server after restart, after TCP connection restoring and periodically every 20 minutes after previous synchronization and then it sends time data on RS485 bus if no communication is detected on the bus i.e. when CPR32 controller is not connected and PR Master software is not operated in Online Monitoring mode. Time synchronization with UT4-DR interface can also be applied in RCP Master Time&Attendance system in standalone mode.

4.5 Memory Reset

Memory reset procedure erases current settings and restores default factory settings.

Memory reset procedure

- Terminate communication with the interface
- Place jumper on contacts according to fig. 8
- Restart the interface (press RESET button or switch power supply off/on) – triple blink of LED STATUS ⏻ (after 5 sec.) confirms that Memory Reset is finished
- Remove the jumper from contacts
- Restart the interface (press RESET button or switch power supply off/on)
- The UT-4DR shall switch to normal mode with default settings. Default settings of the UT-4DR are specified in paragraph 4.1 Configuration with web browser.

Note : After memory reset the configuration of IO1..IO4 lines remains unchanged. In order to reconfigure them it is necessary to establish connection with the interface and change their configuration manually.

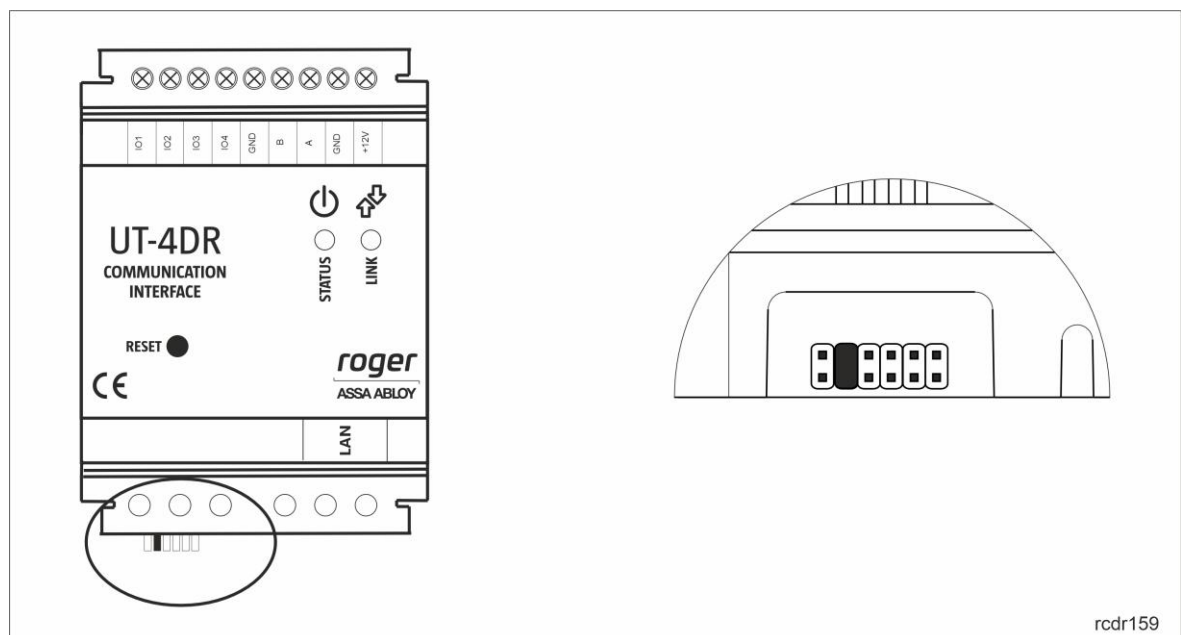

Fig.8 Jumper setting in memory reset procedure.

4.6 Firmware update

The latest versions of firmware is available at www.roger.pl. In order to update firmware it is necessary to connect the device to computer network, enter IP address in web browser and log in. It is not necessary to disconnect the interface from access control system. In the tab **FW Upgrade** (see fig. 4) select *.frg firmware file and upload it to the UT-4DR.

Note: After firmware update it might be necessary to perform Memory Reset according to section 4.5 Memory Reset

5. ORDERING INFORMATION

Table 4. Ordering information	
UT-4DR	Ethernet-RS485 communication interface.
ME-2-D	Metal enclosure with 13.8VDC/3.5A power supply unit.
ME-5-S	Metal enclosure with 13.8VDC/11A power supply unit.
ME-43-S	Metal enclosure with 13.8VDC/4A power supply unit.
ME-44-S	Metal enclosure with 13.8VDC/10A power supply unit.

6. PRODUCT HISTORY

Table 5. Product history		
Product version	Released	Description
UT-4DR v1.0	09/2011	The first commercial version of the product

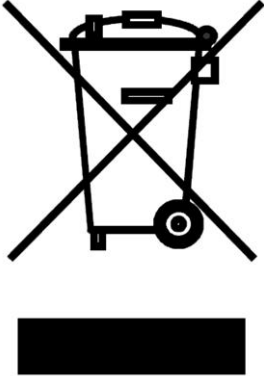
	<p>This symbol placed on a product or packaging indicates that the product should not be disposed of with other wastes as this may have a negative impact on the environment and health. The user is obliged to deliver equipment to the designated collection points of electric and electronic waste. For detailed information on recycling, contact your local authorities, waste disposal company or point of purchase. Separate collection and recycling of this type of waste contributes to the protection of the natural resources and is safe to health and the environment. Weight of the equipment is specified in the document.</p>
---	---

Contact:**Roger sp. z o.o. sp.k.****82-400 Sztum****Gościszewo 59****Tel.: +48 55 272 0132****Fax: +48 55 272 0133****Tech. support: +48 55 267 0126****E-mail: support@roger.pl****Web: www.roger.pl**