

Roger Access Control System

Installation guide for PR411DR/PR411DR-BRD Access Controllers

Firmware version: 1.18.6

Hardware version: 1.6

Document version: Rev. N

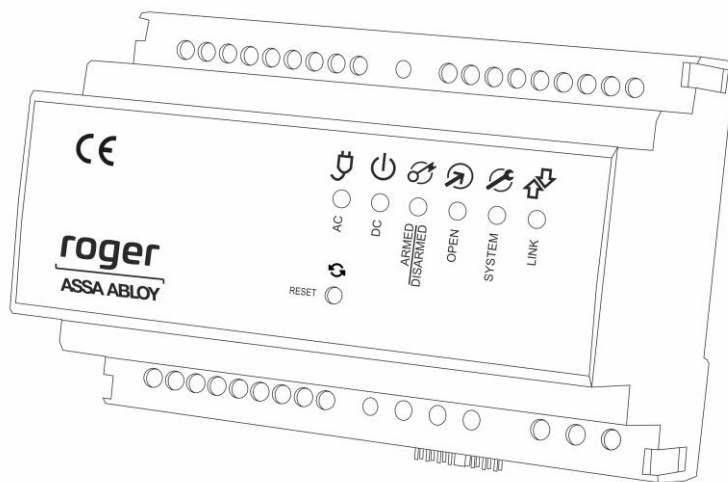

rcdr164

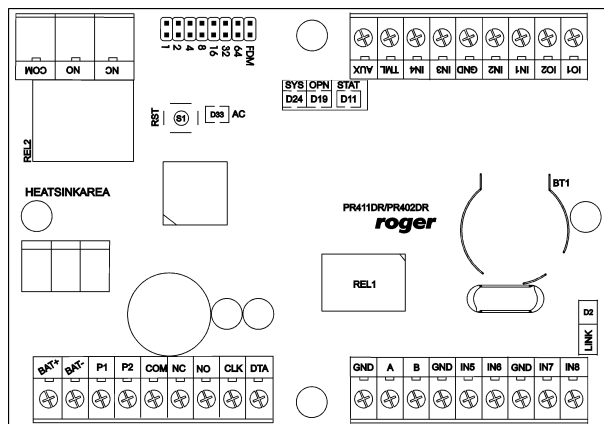

rcdr164

Contents

| | |
|---|-----------|
| 1. Introduction | 3 |
| 1.1 This manual | 3 |
| 2. Description and Specification..... | 3 |
| 3. Installation | 4 |
| 3.1 Terminals and connection diagram | 4 |
| 3.2 Front panel | 7 |
| 3.2.1 PR411DR controller | 7 |
| 3.2.2 PR411DR-BRD controller | 7 |
| 3.3 Power supply | 8 |
| 3.4 Connection of door lock | 10 |
| 3.5 Communication with controller | 11 |
| 3.6 Communication of controller with peripheral devices | 11 |
| 3.6.1 PRT readers and XM-2 expander | 11 |
| 3.6.2 PRT and third party readers (Wiegand)..... | 12 |
| 3.7 Input and output lines | 12 |
| 3.6.1 Inputs..... | 13 |
| 3.6.2 Relay outputs..... | 13 |
| 3.6.3 General purpose outputs..... | 13 |
| 3.8 Installation guidelines..... | 13 |
| 4. Configuration..... | 13 |
| 4.1 Controller address | 13 |
| 4.2 Memory Reset procedure | 15 |
| 4.3 Controller programming..... | 16 |
| 4.4 Firmware update | 16 |
| 5. Ordering information..... | 16 |
| 6. Product history | 17 |

This document is subject to the Terms of Use in the current version published on the website www.roger.pl .The manufacturer reserves the right to make changes to the product without prior notice. © ROGER sp. z o. o. sp.k. All rights reserved.

1. INTRODUCTION

1.1 This manual

This manual contains minimum information that is necessary to properly install devices and to perform initial tests. Following documents which are available at www.roger.pl supplement this manual:

- Functional description of PRxx1 series controllers
- PR Master User Manual

If PR411DR and PR411DR-BRD controllers are not clearly distinguished in particular paragraph, then information specified for PR411DR also applies to PR411DR-BRD. But if PR411DR-BRD name is used in particular paragraph then the information concerns only that specific type of controller.

2. DESCRIPTION AND SPECIFICATION

PR411DR type controller is single door access controller used in RACS 4 access control system. Both PR411DR and PR411DR-BRD versions are functionally identical but differ mechanically. PR411DR is installed inside plastic enclosure fitted to mounting on DIN 35 mm rail, while PR411DR-BRD is just a PCB module without enclosure.

The new, factory-made controller has the address ID=00 and MASTER proximity card is included.

The card can be used for the initial tests after connection of external reader. PR411DR controllers are not equipped with built-in reader, and they require connection of external reader(s) operating in RACS CLK/DTA (PRT series terminals) or Wiegand 26...66bit format.

Controllers can be configured with PR Master software installed on computer and they can be connected to computer by means of communication interface e.g. UT-2USB, UT-4DR, RUD-1 or by means of CPR32-NET network controller. Alternatively, PRxx1 series controllers can be programmed with keypad commands according to the manual Functional description of PRxx1 series controllers.

| | | |
|------------------------|--------|---|
| Nominal voltage | supply | 18VAC 12VDC 24VDC |
| Backup battery | | 13.8V/7Ah, charging current app. 300mA |
| Nominal current | supply | 100 mA (excluding load points connected to AUX and/or TML outputs) |
| Inputs | | Eight (IN1...IN8) NO/NC inputs, electrically biased to +12V via 15k Ω resistor, triggering level app. 3.5V |
| Relay outputs | | Two (REL1 and REL2) relay outputs with single NO/NC contact, 30V/1.5A (REL1) and 30V/5A (REL2) |
| Transistor outputs | | Two (IO1 and IO2) open collector outputs, 15VDC/1A max. load |
| Power outputs | supply | Two power supply outputs: 12VDC/0.2A (TML) and 12VDC/1A (AUX) |
| Distances | | Between controller and communication interface (RS485): max. 1200m Between controller and PRT reader (RACS CLK/DTA): max. 150 m Between controller and XM expander (RACS CLK/DTA): max. 150 m |
| Operating environments | | I general conditions, temperature: +5°C to +40°C, relative humidity: 10 to 97% (no condensation) |
| IP code | | PR411DR: IP20 PR411DR-BRD: n/a |

| | |
|------------------|--|
| Dimensions HxWxD | PR411DR: 85 x 124 x 73mm PR411DR-BRD: 80 x 115 x 28mm |
| Weight | PR411DR: approx. 200g PR411DR-BRD: approx. 100g |
| Certificates | CE, RoHS |

3. INSTALLATION

3.1 Terminals and connection diagram

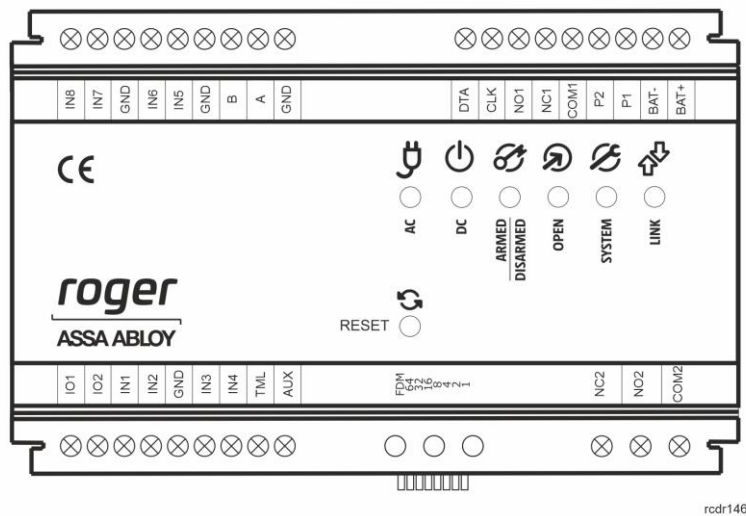
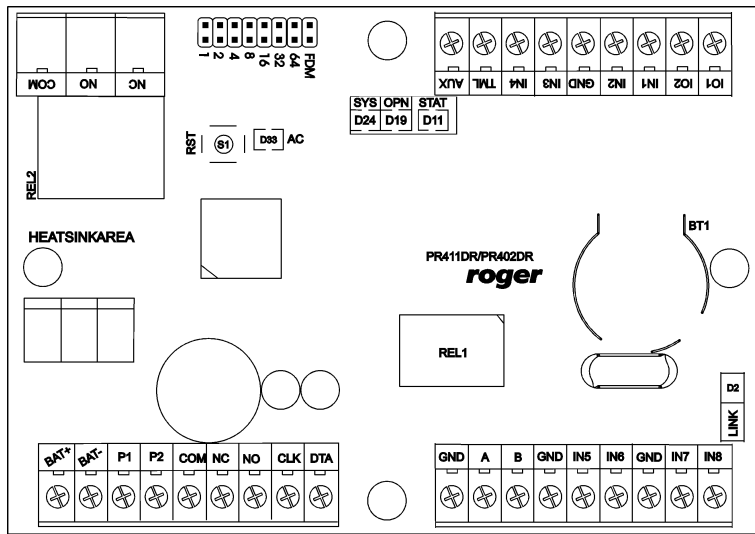

Fig. 1 PR411DR controller

| Terminal | Description | Terminal | Description |
|----------|-------------------------|----------|--|
| IN8 | IN8 input line | P1 | Power supply for controller |
| IN7 | IN7 input line | BAT- | Backup battery |
| GND | Ground | BAT+ | Backup battery |
| IN6 | IN6 input line | IO1 | IO1 output line |
| IN5 | IN5 input line | IO2 | IO2 output line |
| GND | Ground | IN1 | IN1 input line |
| B | RS485 communication bus | IN2 | IN2 input line |
| A | RS485 communication bus | GND | Ground |
| GND | Ground | IN3 | IN3 input line |
| DTA | RACS CLK/DTA comm. bus | IN4 | IN4 input line |
| CLK | RACS CLK/DTA comm. bus | TML | Built-in feeder output 12VDC/0.2A (recommended supply for readers) |
| NO1 | REL1 relay output (NO) | AUX | Built-in feeder output 12VDC/1A (power supply for general purpose) |
| NC1 | REL1 relay output (NC) | NC2 | REL2 relay output (NO) |

| | | | |
|------|-----------------------------|------|----------------------------|
| COM1 | REL1 relay common terminal | NO2 | REL2 relay output (NC) |
| P2 | Power supply for controller | COM2 | REL2 relay common terminal |



rcdr164

Fig. 2 PR411DR-BRD controller

| Table 3. PR411DR-BRD terminals | | | |
|---------------------------------------|-----------------------------|----------|--|
| Terminal | Description | Terminal | Description |
| BAT+ | Backup battery | GND | Ground |
| BAT- | Backup battery | IN7 | IN7 input line |
| P1 | Power supply for controller | IN8 | IN8 input line |
| P2 | Power supply for controller | IO1 | IO1 output line |
| COM | REL1 relay common terminal | IO2 | IO2 output line |
| NC | REL1 relay output (NC) | IN1 | IN1 input line |
| NO | REL1 relay output (NO) | IN2 | IN2 input line |
| CLK | RACS CLK/DTA comm. bus | GND | Ground |
| DTA | RACS CLK/DTA comm. bus | IN3 | IN3 input line |
| GND | Ground | IN4 | IN4 input line |
| A | RS485 communication bus | TML | Built-in feeder output 12VDC/0.2A (recommended supply for readers) |
| B | RS485 communication bus | AUX | Built-in feeder output 12VDC/1A (power supply for general purpose) |
| GND | Ground | NC | REL2 relay output (NO) |
| IN5 | IN5 input line | NO | REL2 relay output (NC) |
| IN6 | IN6 input line | COM | REL2 relay common terminal |

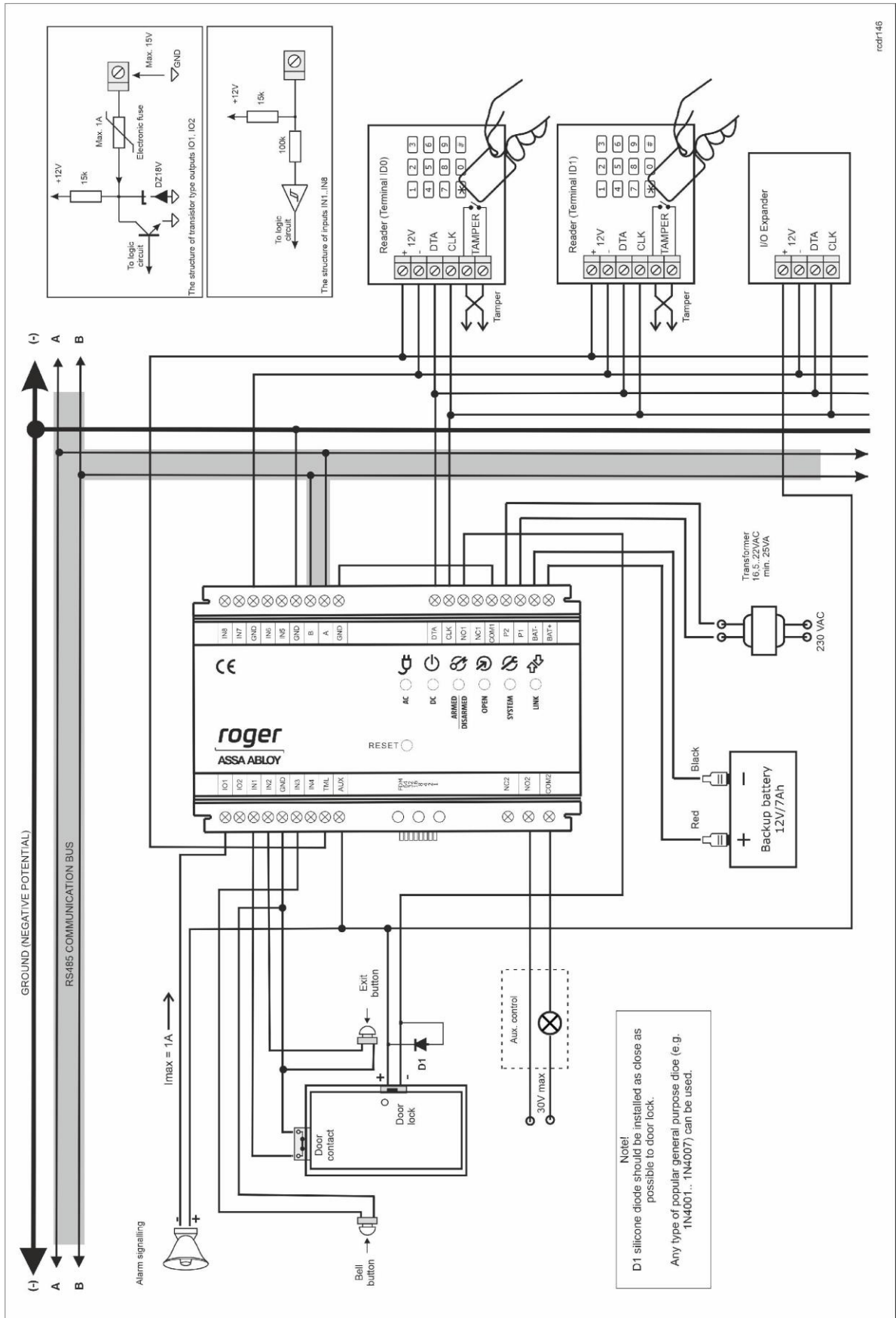

Fig. 3 Typical connection diagram for PR411DR controller

3.2 Front panel

3.2.1 PR411DR controller

According to fig. 4, the PR411DR controller is equipped with LED indicators on front panel to indicate various states of the device and with RESET button to restart the controller in the same way as in case of powering device off and then on. The RESET button can also be used during Memory Reset procedure and during firmware update procedure.

| Table 4. PR411DR front panel | |
|------------------------------|---|
| AC | AC supply |
| DC | DC supply |
| ARMED/DISARMED | Current arming mode |
| OPEN | Door unlocked |
| SYSTEM | Various signalling functions |
| LINK | Data transmission by means of RS485 bus |

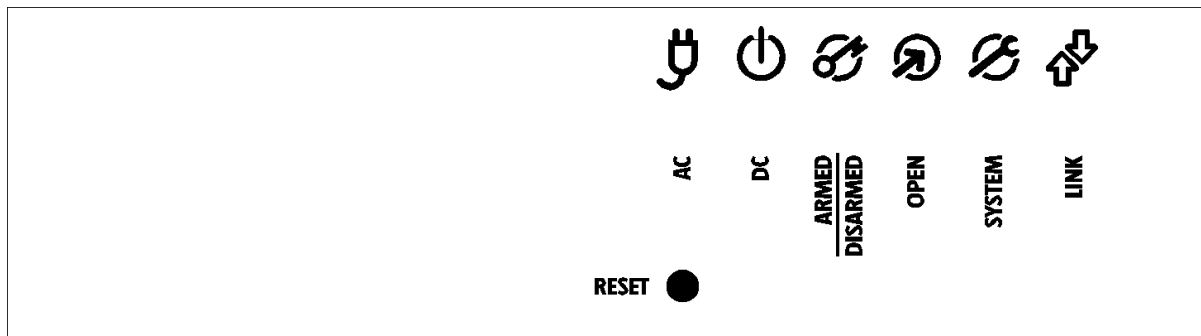

rcdr140

Fig. 4 PR411DR front panel

3.2.2 PR411DR-BRD controller

According to fig. 5, PR411DR-BRD is equipped with 5 LED indicators and RESET button (S1) on its PCB. RESET button can be used to restart the controller in the same way as in case of powering device off and then on. The RESET button can also be used during Memory Reset procedure and during firmware update procedure.

| Table 5. LEDs at PR411DR-BRD controller | |
|---|---|
| AC (D33) | AC supply |
| SYS (D24) | Various signalling functions |
| OPN (D19) | Door unlocked |
| STAT (D11) | Current arming mode |
| LINK (D2) | Data transmission by means of RS485 bus |

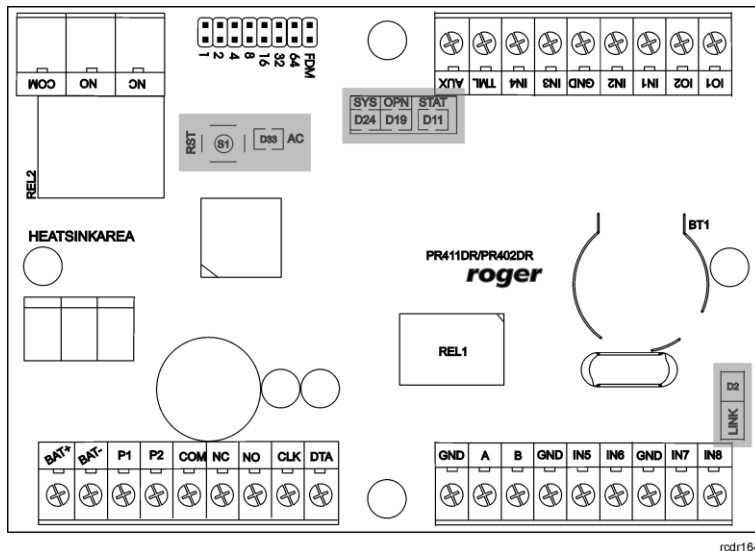

Fig. 5 LEDs at PR411DR-BRD controller PCB

3.3 Power supply

Basically, PR411DR and PR411DR-BRD controllers are designed for power supply from 230VAC/18VAC transformer with minimal power output 25VA, but they can also be supplied with 12VDC or 24VDC. The connection of power supply is shown in fig. 6, fig.7 and fig. 8.

If controller is supplied with 18VAC or 24VDC, then 12V backup battery can be connected in order to provide power supply in case of mains supply shortage. The controller charges backup battery with 300mA stabilized current up to 13.8V. Backup power supply is activated automatically in case of main powers supply shortage. If the voltage at backup battery drops below approx. 10V then the battery is automatically disconnected from controller and remains disconnected until mains power supply returns. Depending on charging phase of backup battery, the voltage at AUX and TML terminals may vary in range of 11V (initial charging phase) to 13.8V (final charging phase) which is not a symptom of failure but it results from applied concept of battery charging.

In case of 12VDC power supply, backup battery cannot be directly connected to controller and in such case backup power supply must be provided by 12VDC power supply unit.

General guidelines for 18VAC power supply

- GND terminals of controllers must be connected with any wire.
- Controllers can operate with directly connected backup batteries.
- Controllers cannot be started using only power supply from backup battery.

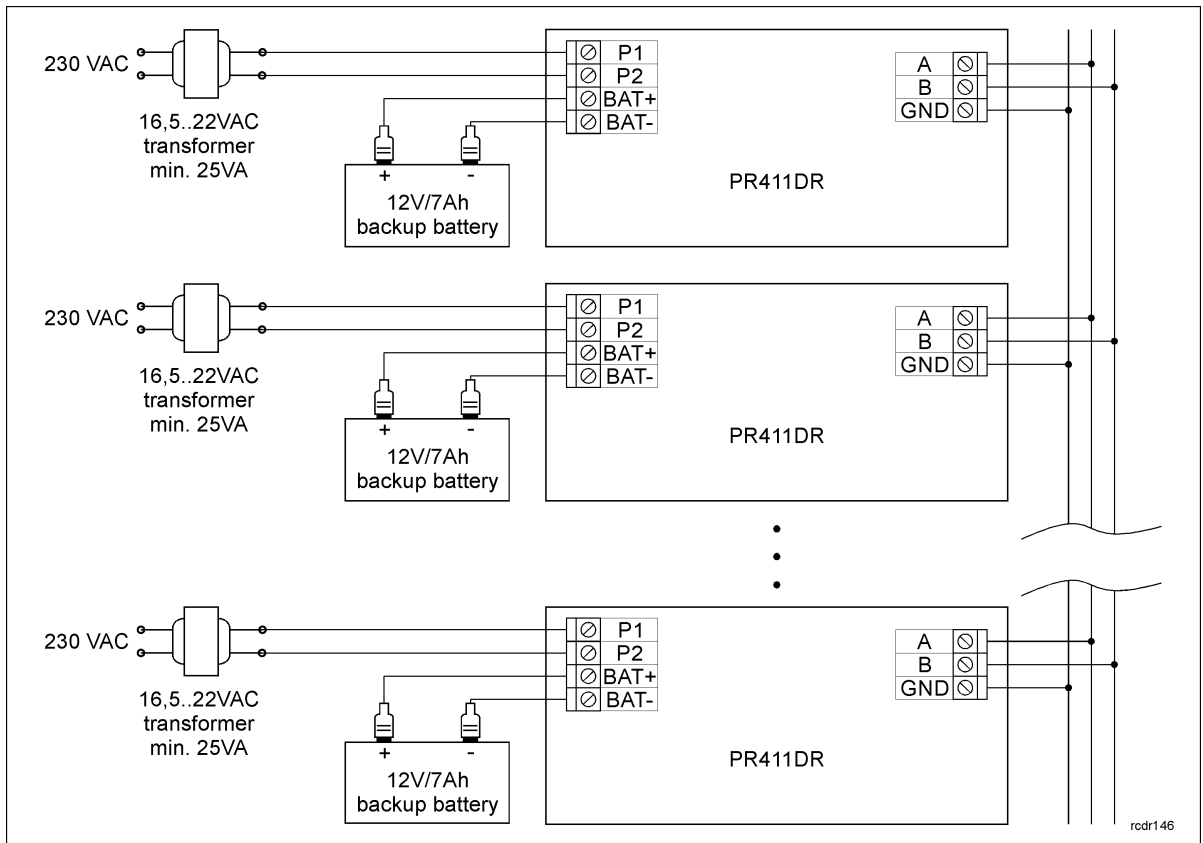

Fig. 6 PR411DR controllers supplied with 18VAC

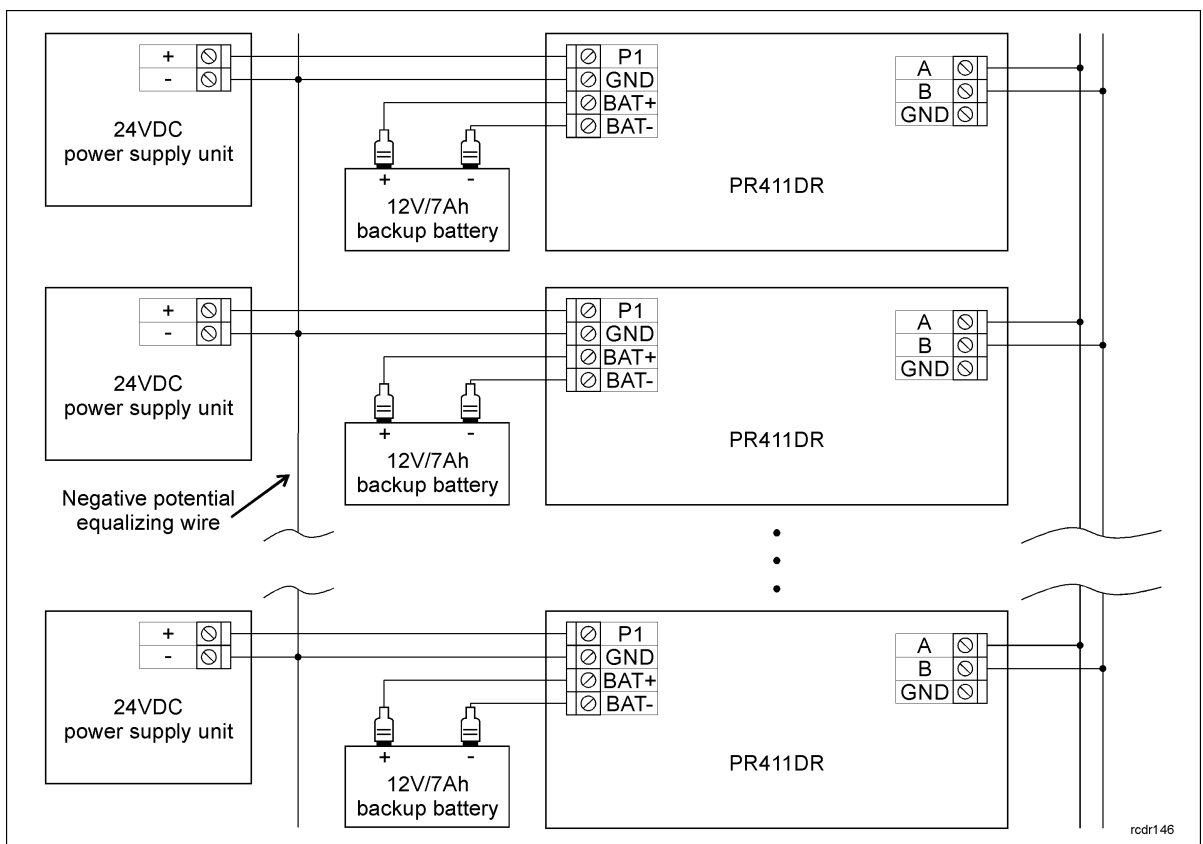

Fig. 7 PR411DR controllers supplied with 24VDC

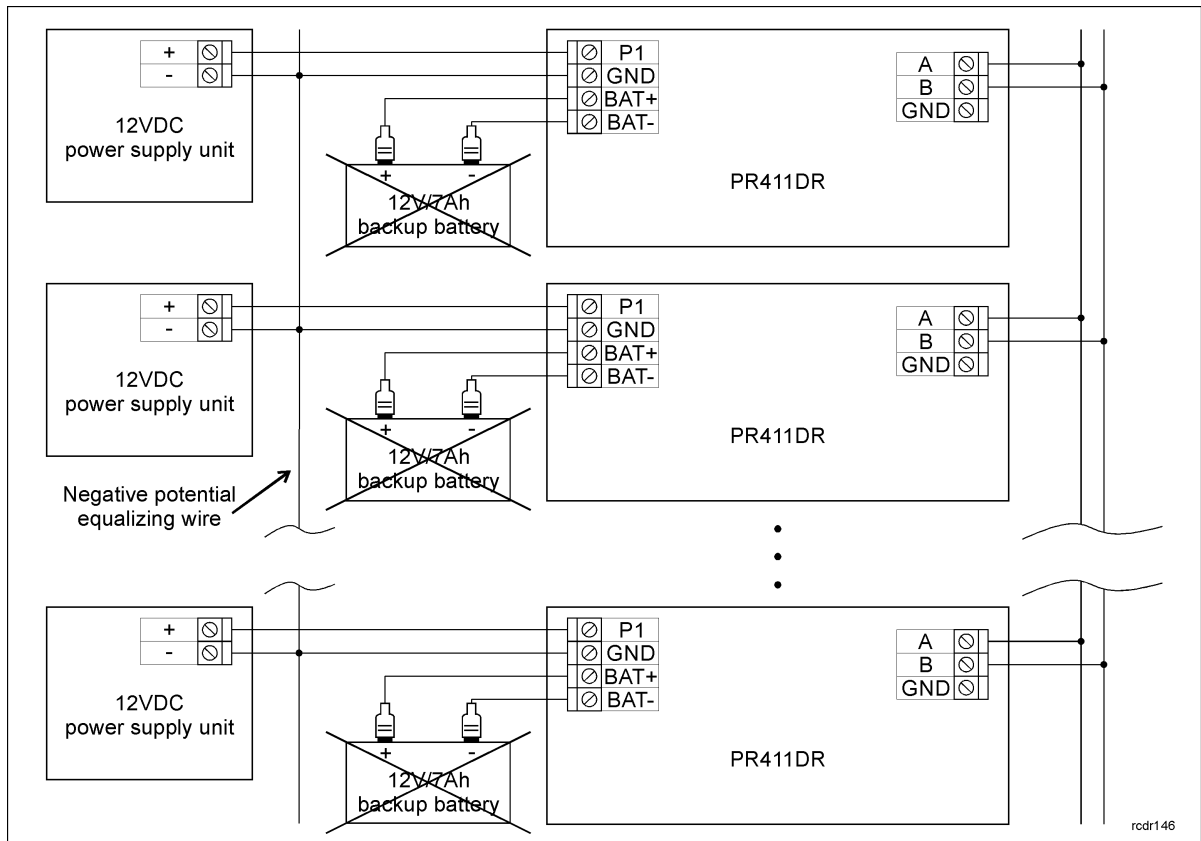

Fig. 8 PR411DR controllers supplied with 12VDC

General guidelines for 24VDC and 12VDC power supply

- Negative (GND) potentials of power supply units must be connected with any wire.
- It is not necessary to connect GND terminals of HRC series controllers.
- Connect controller and power supply unit with separate wire. The wire section must be such as to prevent more than 0.5V voltage drop between controller and unit at maximal load.
- It is recommended to install controller possibly close to power supply unit, preferably in the same room.
- 24VDC supplied controllers can be equipped with backup batteries while in case of 12VDC supplied controllers, backup supply must be ensured on power supply unit side.
- Controllers can be supplied from single power supply unit if the output power is sufficient.

3.4 Connection of door lock

In majority of cases, door locking devices are inductive type. It means that overvoltage (voltage surge) can occur when current flow is interrupted and it can interfere with the controller electronic components. In extreme cases it may result in improper operation of the controller or even freeze. Moreover, overvoltage condition causes quicker wear of relay contacts. In order to limit this adverse effect, it is necessary to use a general type semiconductor diode e.g. 1N4007 (one piece of such diode is included with the controller). The diode should be connected as close as possible to the inductive element (electric strike or magnetic lock).

Door lock can be supplied from controller AUX terminal – see fig. 3 or directly from power supply unit – see figure below.

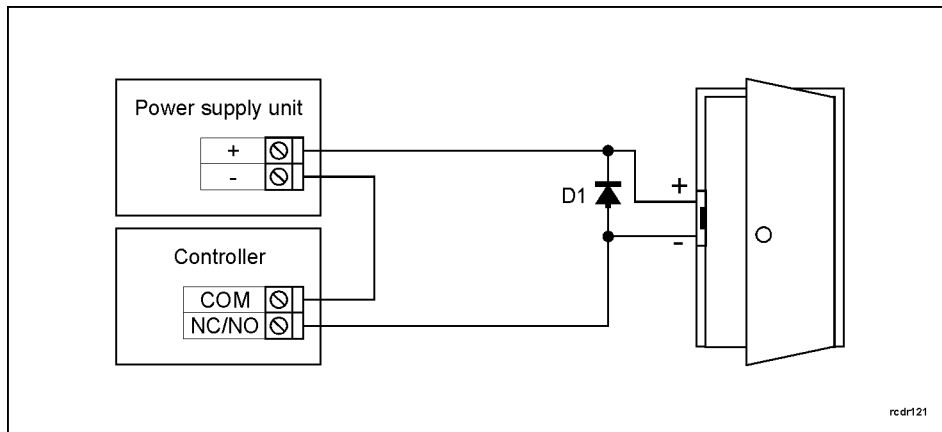

Fig. 9 Connection of door lock

3.5 Communication with controller

RS485 bus and UT communication interface (e.g. UT-2USB) are used for communication with controller. Single RS485 bus creates network (subsystem) and up to 32 controllers with unique addresses in range of 00.99 can be connected to the bus. For the communication with distant subsystems, it is required to use UT-4DR or UT-4 v2.0 communication interface or CPR32-NET network controller as all of them enable communication through computer network (LAN or WAN). The RS485 bus consists of two signal lines A and B. In the RACS 4 system any topology can be used (star, tree or any combination of them, except for loop) to connect controllers in network (subsystem). The matching resistors (terminators) connected at the ends of transmitting lines are not required. In most cases communication works with any cable type (standard telephone cable, shielded or unshielded twisted pair etc.) but the recommended cable is unshielded twisted pair (U/UTP cat.5). Shielded cables should be limited to installations subject to strong electromagnetic interferences. The RS485 communication standard used in the RACS 4 system guarantees proper communication in up to 1200 meters as well as high resistance to interferences.

3.6 Communication of controller with peripheral devices

The communication of controller and peripheral devices can be established by means of RACS CLK/DTA or Wiegand bus. RACS CLK/DTA is the addressable bidirectional communication standard developed by Roger company. Addresses of all devices connected to CLK and DTA lines must be properly configured in range of 0...15. Factory default address of peripheral devices can be changed according to procedures specified in their manuals but in majority of cases it is not necessary to modify the addresses at all. Standard unshielded signal cables (e.g. U/UTP cat. 5) with maximal length of 150m can be used for RACS CLK/DTA communication. Practically, devices communicating on RACS CLK/DTA bus can be connected to the controller in distance up to 500m, but such conditions are not guaranteed by the manufacturer. Wiegand communication standard is commonly used in access control industry, but it offers less functionalities than RACS CLK/DTA standard.

3.6.1 PRT readers and XM-2 expander

PR411DR controller can operate with two PRT series readers and XM-2 I/O expander – see fig. 10. Addresses of PRT readers must be ID=0 and ID=1 and the address of XM-2 expander must be ID=5. All mentioned devices must be connected to CLK and DTA lines of the controller.

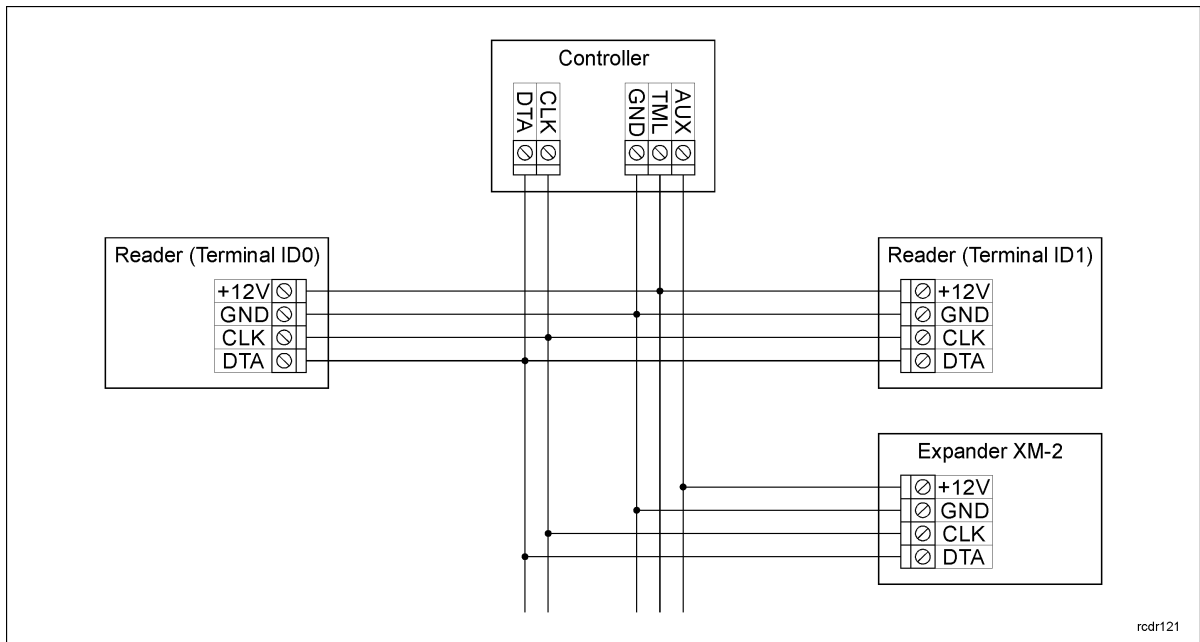

Fig. 10 Connection of PRT series readers and XM-2 expander

Note: Practically, devices communicating in RACS CLK/DTA standard (e.g. PRT readers) can be connected to the controller for significantly greater distances than 150m (even up to 500m), but the communication in such distance is not guaranteed by the manufacturer.

3.6.2 PRT and third-party readers (Wiegand)

The connection of Wiegand readers is shown in fig. 11. Wiegand interface readers can be connected to controller along with PRT series readers connected to CLK/DTA lines. When so, users can authorize alternatively on PRT or Wiegand reader. In case of Wiegand/Magstripe readers it is necessary to select adequate data format, otherwise controller will not recognize transmissions from the reader. Data format can be selected by means of PR Master software. If particular Wiegand reader does not work properly with the controller, it might be necessary to use PR-GP module. The PR-GP works as electrical interface between reader and controller. In order to determine if PR-GP might be useful, please contact Roger technical support.

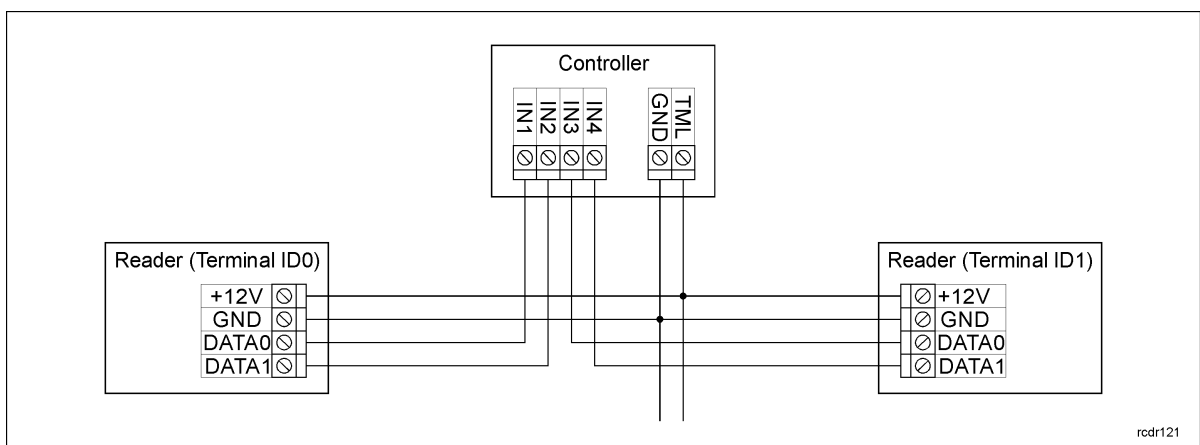

Fig. 11 Connection of Wiegand readers

3.7 Input and output lines

Functions are assigned to inputs and outputs by means of PR Master software or by means of manual programming (keypad commands). Default function for REL1 relay output is door unlock.

3.6.1 Inputs

All inputs (IN1...IN8) of controllers have identical electric structure and can be configured as NO or NC lines using PR Master software. The NO input is triggered by shorting it to supply minus (GND) while the NC input must be normally shorted to supply minus (GND) and it becomes triggered when connection with GND is interrupted. Every input is internally connected (pulled up) to the power supply plus (+12V) through a 15kΩ resistor.

3.6.2 Relay outputs

Controllers offer two relay outputs (REL1, REL2), each with single switching contact. Maximum load for REL1 equals to 30V/1.5A while maximum load for REL2 equals to 230VAC/5A and also 30VDC/5A. In the normal state (relay is off) the NC-COM contacts are shorted. In the triggering state (relay is on) the NO-COM contacts are shorted. In case of power outage both relays remain in the off state.

3.6.3 General purpose outputs

Controllers offer two transistor outputs (IO1, IO2). Both outputs are open collector type i.e. in normal (off) state are pulled to supply plus via 15kΩ resistor and when in trigger (on) state they short to supply minus. Maximum load for each output equals to 15VDC/1A. In case of overcurrent outputs are automatically switched off and controller automatically restarts.

3.8 Installation guidelines

- Install devices in such way as to ensure easy access to screw terminals, addressing jumpers, RST button and FDM jumper of the controller.
- Prior to controller installation it is recommended to set its address (ID number) – see 4.1 Controller address.
- The controller is delivered with MASTER proximity card, however any proximity card in EM 125kHz (UNIQUE) standard can be programmed as MASTER card.
- All electric connections must be made with power supply switched off..
- All devices connected to the same communication bus (RS485 and RACS CLK/DTA) should be connected to the same negative potential (GND). In order to satisfy this requirement connect the power supply according to section 3.3 Power supply
- General purpose diode e.g. 1N4007 should be always connected in parallel and as close as possible to the door locking device (magnetic lock, electric strike, relay, contactor).
- It is required to install readers in minimal distance of 0.5m from each other. If two readers have to be installed on opposite sides of the same wall, it is recommended not to place them directly opposite (in the same axis). If this condition cannot be fulfilled, then place metal plate between reader and wall as well as non-metal spacer with 10mm minimal thickness between reader and metal plate.
- Because of relatively low magnetic field readers should not interfere with other devices, however its operation can be disrupted by devices generating strong electromagnetic field.
- If the range of card reading is significantly lower than specified in technical documentation, then consider relocation of the reader.
- Readers can be installed on metal surfaces but in such case reduction of reading distance should be expected. The reading distance reduction effect can be minimized by installing readers on non-metal spacer with minimal thickness of 10 mm (e.g. PVC).
- The electronic device/module contains electronic components sensitive to ESD. Activities involving contact with the electronic module may only be performed by a person free from the electrostatic charge.
- The installation may only be performed by a qualified person with appropriate permits and authorizations for connecting and intervening in 230VAC and low-voltage networks.

4. CONFIGURATION

4.1 Controller address

If controller works autonomously (standalone mode), then address setting can be skipped and default address ID =00 can be used but if the controller is to be connected with other controllers by means of RS485 bus and operate in network system, then it is necessary to assign unique address

to such controller (ID number from range 00..99). Two or more devices with the same address result in communication conflict and make a proper communication with these devices impossible. Following addressing methods are available:

- By means of jumpers
- During update of controller firmware by means of Roger ISP software (so called Fixed ID)
- Manually during Memory Reset procedure
- By means of PR Master software

The first two methods enable configuration of hardware addresses while the remaining two enable configuration of software addresses. The main difference between these two addressing methods is such that software address contrary to hardware address can be modified using any of mentioned methods. Jumper address has the highest priority, Fixed ID has lower priority and software addresses have the lowest priority.

Note: A new controller can be connected to the existing system without the necessity to change its address but only if no other controller operates with default address ID=00. Once the controller is connected to the RS485 communication bus, it should be detected by means of PR Master software and new address should be configured.

4.1.1 Setting the address by means of jumpers

The address of controller can be set by means of jumpers – see fig. 12. Each time the new address is configured, controller must be restarted (via RESET button or powering device off and on) to make new settings valid. The address range is 00...127 and if the address is in range 100...127 then the controller ignores such setting, and all other addressing methods can be used. If the address is in range of 00...99 then it has the highest priority, FixedID is not effective, and the address cannot be changed by PR Master software nor manually during Memory Reset procedure.

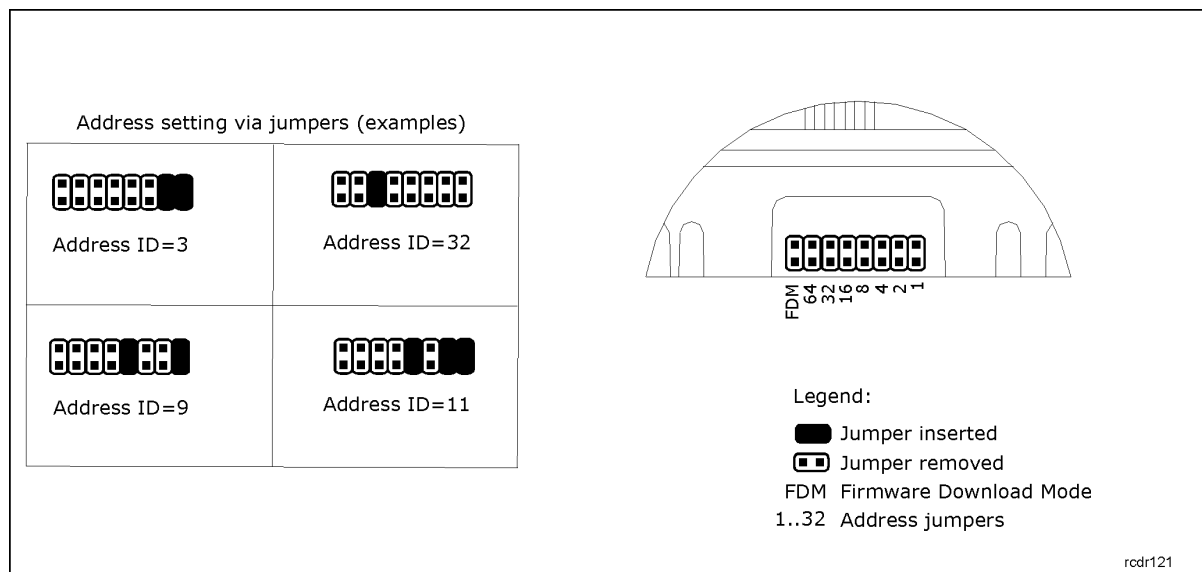

Fig. 12 Addressing jumpers

4.1.2 Addressing during firmware update (Fixed ID)

FixedID can be set during update of the controller firmware by means of RogerISP software. Prior to firmware upload, RogerISP software offers the possibility to set Fixed ID address in range of 00...99 or disable it (FixedID=None). Once the FixedID is selected and uploaded to the controller software addressing is ignored. In order to disable or modify FixedID it is necessary to start firmware upload procedure or configure jumper address in range of 00...99.

Note: When FixedID is configured then controller address cannot be modified based on software addressing method. FixedID address is maintained even in case of controller configuration error.

Therefore, controller can be always detected on the communication bus with the same address by means of PR Master software.

4.1.3 Addressing during Memory Reset procedure

Software address can be configured during Memory Reset procedure – see 4.2 Memory Reset procedure.

Note: Software address is effective only if the address set with jumpers on the controller is in range of 100...127 and FixedID is None.

4.1.4 Addressing by means of PR Master software

Software address can be configured by means of PR Master software. In such case connect the controller to PC via communication interface (e.g. UT-2USB, UT-4DR) or via CPR32-NET network controller, detect the controller and configure the address.

Note: Software address is effective only if the address set with jumpers on the controller is in range of 100...127 and FixedID is None.

4.2 Memory Reset procedure

Memory Reset procedure erases current settings and restores default factory settings. Additionally Full Memory Reset enables to program new MASTER card/PIN as well as new address of the controller. After Memory Reset procedure the controller automatically enters normal working mode.

Note: If current address of the controller is hardware type (see 4.1 Controller address) i.e. FixedID or configured by means of jumpers in range of 00..99 then address selected during Memory Reset procedure is ignored.

4.2.1 Simplified Memory Reset Procedure

Simplified Memory Reset restores default settings with controller address ID=00 and enables programming of new MASTER card. This procedure requires connection of any PRT series reader.



- Remove connections to CLK and DTA terminals
- Connect CLK with DTA
- Restart the controller (press RESET button or switch power supply off/on) - LED OPEN  shall start to pulsate
- Disconnect CLK and DTA
- Connect PRT series reader to CLK and DTA lines (without switching power supply off) and execute further steps by means of that reader.
- Read any card at the reader, this will be a new MASTER card
- After a few seconds the controller shall restart automatically and switch to normal mode

4.2.2 Full Memory Reset procedure

Full Memory Reset restores default settings and enables programming of new MASTER card, MASTER PIN and controller ID address. This procedure requires connection of PRT series reader with keypad (e.g. PRT12LT).

- Remove connections to CLK and DTA terminals
- Connect CLK with DTA
- Restart the controller (press RESET button or switch power supply off/on) – LED OPEN  shall start to pulsate
- Disconnect CLK and DTA
- Connect PRT series reader with keypad (e.g. PRT12LT) to CLK and DTA lines (without switching power supply off) and execute further steps by means of that reader.
- Enter new MASTER PIN (3 to 6 digits) followed with the [#] key or skip this step and press only the [#] key
- Read any card at the reader, this will be a new MASTER card or skip this step and press only the [#] key

- Enter two digits (in range of 00 to 99) by means of keypad, this will be new ID address or skip this step and press only the [#] key so the default ID=00 could be assigned
- After a few seconds the controller shall restart automatically and switch to normal mode

After Memory Reset controller resumes its work with default factory settings and configured address. You can then test its operation using MASTER card or PIN (if available). Using the MASTER card/PIN once activates the REL1 output for 4 seconds (LED OPEN ). Using the MASTER card/PIN twice switches the IO1 output to the opposite state and switches Arm/Disarm Mode (LED STATUS  changes its colour).

4.3 Controller programming

Controllers can be configured by means of:

- PR Master software installed on computer connected to the controller via communication interface (e.g. UT-2USB, UT-4DR) or via CPR32-NET network controller.
- By means of command entered with keypad. In such case PRT series reader with keypad must be connected to the controller.

More information on controller programming can be found in the document Functional description of PRxx1 series controllers as well as in PR Master User Manual which are available at www.roger.pl.

4.4 Firmware update

The latest versions of firmware and Roger ISP software are available at www.roger.pl. In order to update firmware it is necessary to connect the device by means of RS485 bus to communication interface (UT-2USB or RUD-1) and then connect the interface to PC with installed Roger ISP software. It is not necessary to disconnect the controller from access control system it is only required to place FDM jumper in order to put the device in firmware download mode. Therefore, firmware update can be performed by means of RS485 bus of access control system.

Firmware update procedure

- Place jumper on FDM pins (see fig. 12)
- Reset device (press RESET button or switch power off/on)
- Start RogerISP software and select communication port (in case of RUD-1 select **USB-RS485 Converter**).
- Press the button **Erase**
- Once more reset the device (place and remove jumper on RST pins or switch power off/on)
- In Firmware window select firmware *.hex file (can be downloaded from www.roger.pl) and then select the button **Program**
- After firmware upload remove jumper from FDM pins and reset device (place and remove jumper on RST contacts or switch power off/on)

Note: If the controller is not responding and LED SYSTEM  (orange) is on after firmware update procedure then it is necessary to perform reset – see 4.2 Memory Reset procedure or update the firmware once more.

In case of network system, it is required to restart controller within PR Master software by right clicking particular controller and selecting the option **Restart controller and verify version**.



5. ORDERING INFORMATION

| Table 6. Ordering information | |
|-------------------------------|--|
| PR411DR | Access controller in enclosure adapted for installation on DIN 35mm rail. |
| PR411DR-BRD | Electronic module of PR411DR controller. |
| PR411DR-SET | Access control set including PR411DR access controller, metal enclosure and DC power supply. |

| | |
|-----------|--|
| ME-2-S | Metal enclosure with 80VA transformer, adapted for 4 x PR411DR-BRD controllers |
| CPR32-NET | Electronic module of network controller. |
| UT-4DR | Ethernet-RS485 communication interface. |
| UT-2USB | USB-RS485 communication interface. |
| RUD-1 | Portable USB-RS485 communication interface with 12VDC/0.12A output. |
| XM-2DR | I/O expander. |

6. PRODUCT HISTORY

| Table 7. Product history | | |
|--------------------------|----------|---|
| Product version | Released | Description |
| PR411DR v.1.0 | 05/2011 | The first commercial version of the product |
| PR411DR v.1.1 | 02/2012 | Modification of built-in converter |
| PR411DR v.1.2 | 08/2012 | Terminal TML is added |
| PR411DR v.1.3 | 07/2013 | Modifications of controller's power supply terminals |
| PR411DR v.1.4 | 02/2016 | Secondary modifications of RS485 protection, REL2 galvanic separation and battery assembly. |
| PR411DR v1.5 | 06/2025 | REL2 output ratings changed |
| PR411DR v1.6 | 11/2025 | Modification in main board. |

| | |
|--|---|
|   | <p>This symbol placed on a product or packaging indicates that the product should not be disposed of with other wastes as this may have a negative impact on the environment and health. The user is obliged to deliver equipment to the designated collection points of electric and electronic waste. For detailed information on recycling, contact your local authorities, waste disposal company or point of purchase. Separate collection and recycling of this type of waste contributes to the protection of the natural resources and is safe to health and the environment. Weight of the equipment is specified in the document.</p> |
|--|---|

Contact:
Roger sp. z o.o. sp.k.
82-400 Sztum
Gościszewo 59
Tel.: +48 55 272 0132
Fax: +48 55 272 0133
Tech. support: +48 55 267 0126
E-mail: support@roger.pl
Web: www.roger.pl