

*Roger Access Control System*

**Installation guide for PR611, PR611-VP, PR621, PR311SE  
and PR311SE-BK access controllers**

*Firmware version: x.18.6 or newer*

*Document version: Rev. 0*

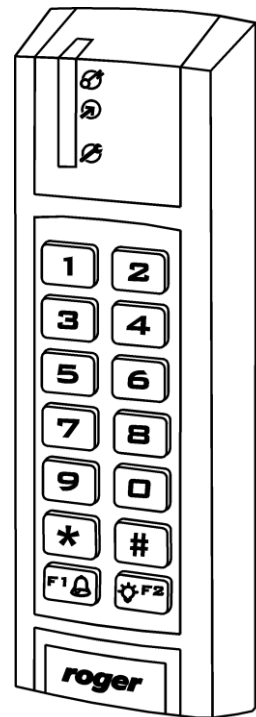
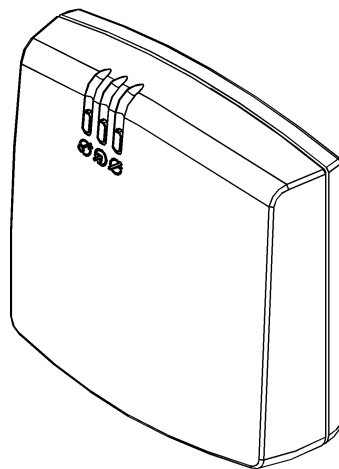
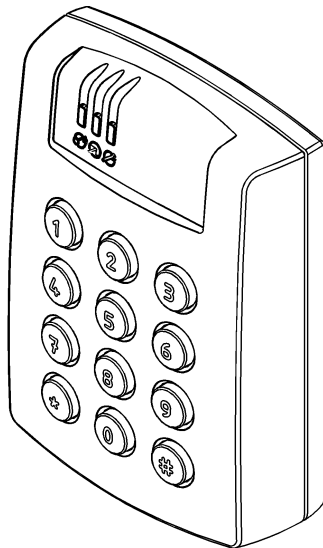

## Contents

<b>1. Introduction .....</b>	<b>3</b>
<b>2. Description and specification .....</b>	<b>3</b>
<b>3. Installation .....</b>	<b>4</b>
3.1 Terminals/wires and connection diagram .....	4
3.2 LED indicators .....	5
3.3 Power supply .....	6
3.4 Connection of door lock .....	6
3.5 Communication with controller .....	6
3.6 Communication of controller with peripheral devices .....	7
3.7 Input and output lines .....	7
3.7.1 Inputs.....	7
3.7.2 Relay outputs.....	7
3.7.3 General purpose outputs.....	7
3.8 Wall mounting.....	8
3.9 Installation guidelines.....	12
<b>4. Configuration.....</b>	<b>12</b>
4.1 Controller address .....	12
4.1.1 Addressing during firmware update (Fixed ID) .....	13
4.1.2 Addressing during Memory Reset procedure.....	13
4.1.3 Addressing by means of PR Master software .....	13
4.1.4 Addressing by means of command entered with keypad .....	13
4.2 Memory Reset procedure .....	13
4.2.1 Simplified Memory Reset Procedure .....	13
4.2.2 Full Memory Reset procedure .....	14
4.2.3 Full Memory Reset procedure (controller without keypad) .....	14
4.3 Controller programming.....	14
4.4 Firmware update .....	15
<b>5. Ordering information.....</b>	<b>15</b>
<b>6. Product history .....</b>	<b>16</b>

This document is subject to the Terms of Use in the current version published on the website [www.roger.pl](http://www.roger.pl). The manufacturer reserves the right to make changes to the product without prior notice. © ROGER sp. z o. o. sp.k. All rights reserved.

## 1. INTRODUCTION

This manual contains minimum information that is necessary to properly install devices and to perform initial tests. Following documents which are available at [www.roger.pl](http://www.roger.pl) supplement this manual:

- Functional description of PRxx1 series controllers
- PR Master User Manual

## 2. DESCRIPTION AND SPECIFICATION

PR611, PR611-VP, PR621, PR311SE and PR311SE-BK are single door access controllers used in RACS 4 access control system. All devices are functionally identical but PR611, PR611-VP and PR311SE are equipped with keypad while PR621 and PR311SE-BK are not. Additionally, PR611-VP controller contrary to remaining ones is equipped with aluminium vandal-proof enclosure. All mentioned controllers are equipped with built-in EM125kHz proximity card reader.

The new, factory-made controller has the address ID=00 and MASTER proximity card is included. The card can be used for initial tests after installation. Additional external reader operating in RACS CLK/DTA (PRT series terminal) format can be connected if it is required to provide read in and read out control.

Controllers can be configured with PR Master software installed on computer and they can be connected to computer by means of communication interface e.g. UT-2USB, UT-4DR, RUD-1 or by means of CPR32-NET-BRD network controller. Alternatively PRxx1 series controllers can be programmed with keypad commands according to the manual Functional description of PRxx1 series controllers.

<b>Table 1. Specification</b>	
Nominal supply voltage	12VDC
Proximity cards	EM 125 kHz (UNIQUE) according to EM4100/4102
Reading distance	Up to 15 cm for ISO cards (depends on card type and quality), up to 8cm in case of PR611-VP. Note: Reading distance is defined for good quality proximity cards placed in optimal position against the controller. For all controllers except for PR611-VP the optimal position for card reading is in the front of the device (card surface parallel to the front). For PR611-VP the optimal position for card reading is from the left and right side of the device (card surface perpendicular to the front).
Nominal current consumption	PR611/PR611-VP/PR311SE: 70mA PR621/PR311SE-BK: 50mA
Tamper	Isolated contact, NC type, 24V/50 mA rated
Inputs	Three (IN1..IN3) NO/NC inputs, electrically biased to +12V via 15kΩ resistor, triggering level approx. 3.5V
Relay output	One (REL1) relay output with single NO/NC contact, 30V/1.5A
Transistor outputs	Two (IO1,IO2) open collector outputs, 15VDC/1A
Distances	Between controller and communication interface (RS485): max. 1200m Between controller and PRT reader (RACS CLK/DTA): max. 150 m Between controller and XM expander (RACS CLK/DTA): max. 150 m
Operating	General outdoor conditions: temperature: -25°C to +60°C, relative

environment	humidity: 10 to 95% (no condensation)	
IP	IP65 Note 1: The IP65 rating is guaranteed if the bottom of the housing is tightly adhered to the surface on which the device is installed. It is the installer's responsibility to seal the space between the bottom of the housing and the surface on which the device is mounted	
Dimensions HxWxD	PR611/PR611-VP:	115 x 80 x 35 mm
	PR621:	85 x 85 x 27 mm
	PR311SE/PR311SE-BK:	152,5 x 46 x 23(35)mm
Weight	PR611/PR621:	approx. 120g
	PR611-VP:	approx. 470g
	PR311SE/PR311SE-BK:	approx. 150g
Compliance	CE, RoHS	

## 3. INSTALLATION

### 3.1 Terminals/wires and connection diagram

<b>Table 2. Terminals and wires</b>		
Screw terminal (PR611/PR621)	Wire colour (PR311SE)	Description
+12V	Red	12VDC power supply
GND	Black	Ground
IN1	Pink	IN1 input line
IN2	Blue	IN2 input line
IN3	White-yellow	IN3 input line
RS485 A	Brown	RS485 communication bus
RS485 B	Green-white	RS485 communication bus
CLK	White	RACS CLK/DTA comm. bus
DTA	Green	RACS CLK/DTA comm. bus
TMP A	Grey	Tamper switch
TMP B	Yellow	Tamper switch
IO1	Yellow-brown	IO1 output line
IO2	Green-brown	IO2 output line
REL1-NC	Grey-pink	REL1 relay output (NC)
REL1-COM	Red-blue	REL1 relay common terminal
REL1-NO	Violet	REL1 relay output (NO)

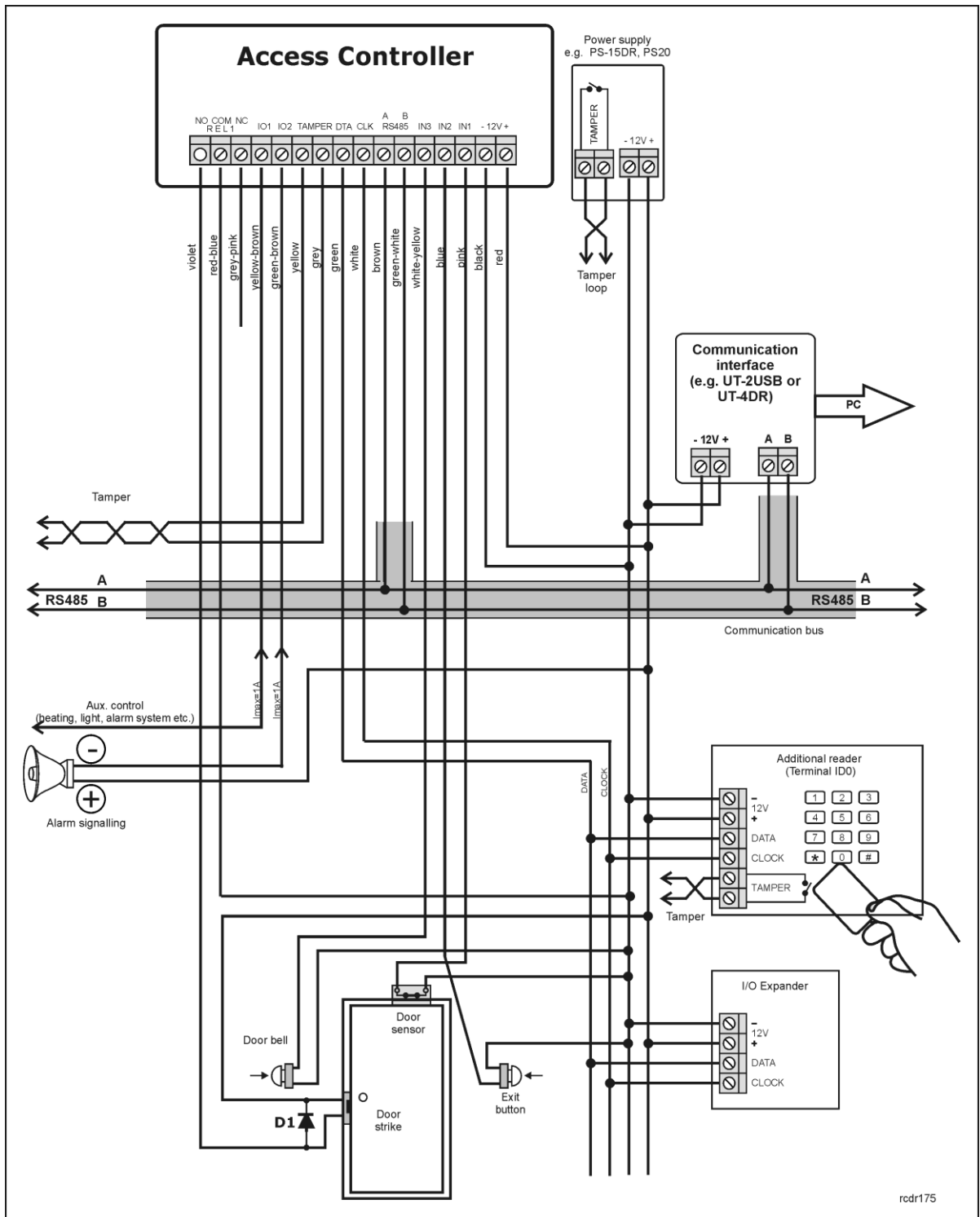





Fig. 1 Connection diagram

### 3.2 LED indicators

Controllers are equipped with 3 LED indicators. Their functions and colours are specified in table 3 below. Functioning of LEDs can be verified by means of included MASTER card after connection of power supply to the controller.

<b>Table 3. LED indicators</b>			
Symbol	Name	Colour	Description
	STATUS	Red/Green	Armed/Disarmed Mode respectively
	OPEN	Green	Door unlocking
	SYSTEM	Orange	Various system functions and programming

### 3.3 Power supply

Controllers require 12VDC nominal power supply. The power should be connected to the +12V line and -12V line. Additionally, the -12V line can be used as reference potential for the RS485 bus, IN1-IN3 input lines and RACS LCK/DTA bus.

The power supply can be provided by means of power supply unit (e.g. PS-15DR, PS20) which can be equipped with backup battery in order to ensure operation of access control in case of power failure.

Note: All devices connected to RS485 bus (including controllers) should have the same supply minus (GND). In order to ensure this, all the GND terminals from various power supply units within the system should be connected with each other using separate wire. Alternatively, the common supply minus of the entire system can be earthed however only in one point.

### 3.4 Connection of door lock

In majority of cases, door locking devices are inductive type. It means that overvoltage (voltage surge) can occur when current flow is interrupted and it can interfere with the controller electronic components. In extreme cases it may result in improper operation of the controller or even freeze. Moreover, overvoltage condition causes quicker wear of relay contacts. In order to limit this adverse effect, it is necessary to use a general type semiconductor diode e.g. 1N4007 (one piece of such diode is included with the controller). The diode should be connected as close as possible to the inductive element (electric strike or magnetic lock).

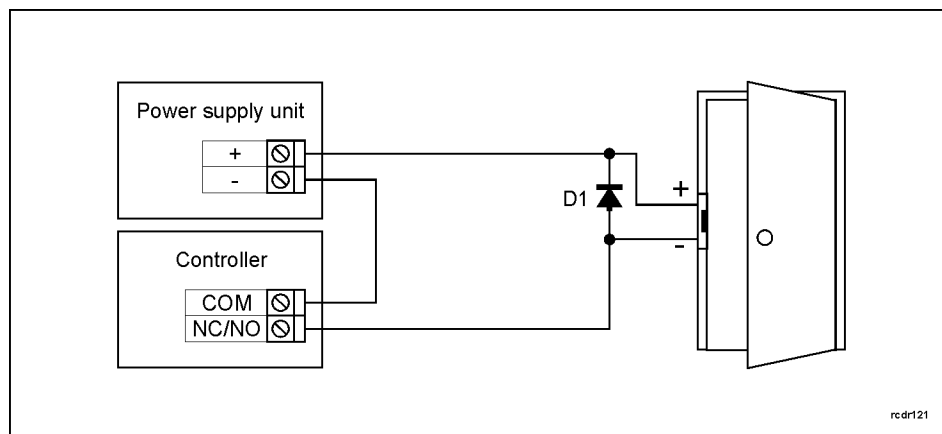

Fig. 2 Connection of door lock

### 3.5 Communication with controller

RS485 bus and UT communication interface (e.g. UT-2USB) are used for communication with controller. Single RS485 bus creates network (subsystem) and up to 32 controllers with unique addresses in range of 00.99 can be connected to the bus. For the communication with distant subsystems it is required to use UT-4DR or UT-4 v2.0 communication interface or CPR32-NET-BRD network controller as all of them enable communication through computer network (LAN or WAN).

The RS485 bus consists of two signal lines A and B. In the RACS 4 system any topology can be used (star, tree or any combination of them, except for loop) in order to connect controllers in network (subsystem). The matching resistors (terminators) connected at the ends of transmitting lines are not required. In most cases communication works with any cable type (standard telephone cable, shielded or unshielded twisted pair etc.) but the recommended cable is unshielded twisted pair (U/UTP cat.5). Shielded cables should be limited to installations subject to strong electromagnetic interferences. The RS485 communication standard used in the RACS 4 system guarantees proper communication in a distance of up to 1200 meters as well as high resistance to interferences.

### 3.6 Communication of controller with peripheral devices

The communication of controller and peripheral devices can be established by means of RACS CLK/DTA. RACS CLK/DTA is the addressable bidirectional communication standard developed by Roger company. Addresses of all devices connected to CLK and DTA lines must be properly configured in range of 0..15. Factory default address of peripheral devices can be changed according to procedures specified in their manuals but in majority of cases it is not necessary to modify the addresses at all. Standard unshielded signal cables (e.g. U/UTP cat. 5) with maximal length of 150m can be used for RACS CLK/DTA communication. Practically, devices communicating on RACS CLK/DTA bus can be connected to the controller in distance up to 500m, but such conditions are not guaranteed by the manufacturer.

The controller is equipped with built-in reader and can operate with external PRT series reader and XM-2 I/O expander. The address of PRT reader must be ID=0 (i.e. default address) and the address of XM-2 expander must be ID=5. All mentioned devices must be connected to CLK and DTA lines of the controller.

### 3.7 Input and output lines

The functions are assigned to inputs and outputs by means of PR Master software or keypad commands. Default function for REL1 relay output is door unlocking.

#### 3.7.1 Inputs

All inputs (IN1..IN3) of controllers have identical electric structure and can be configured as NO or NC lines using PR Master software. The NO input is triggered by shorting it to supply minus (GND) while the NC input must be normally shorted to supply minus (GND) and it becomes triggered when connection with GND is interrupted. Every input is internally connected (pulled up) to the power supply plus (+12V) through a 15k $\Omega$  resistor.

#### 3.7.2 Relay outputs

Controllers offer one relay output (REL1) with single switching contact. Maximum load for REL1 equals to 30V/1.5A. In the normal state (relay is off) the NC-COM contacts are shorted. In the triggering state (relay is on) the NO-COM contacts are shorted. In case of power outage both relays remain in the off state.

#### 3.7.3 General purpose outputs

Controllers offer two transistor outputs (IO1, IO2). Both outputs are open collector type i.e. in normal (off) state are pulled to supply plus via 15k $\Omega$  resistor and when in trigger (on) state they short to supply minus. Maximum load for each output equals to 15VDC/1A. In case of overcurrent outputs are automatically switched off and controller automatically restarts.

### 3.8 Wall mounting

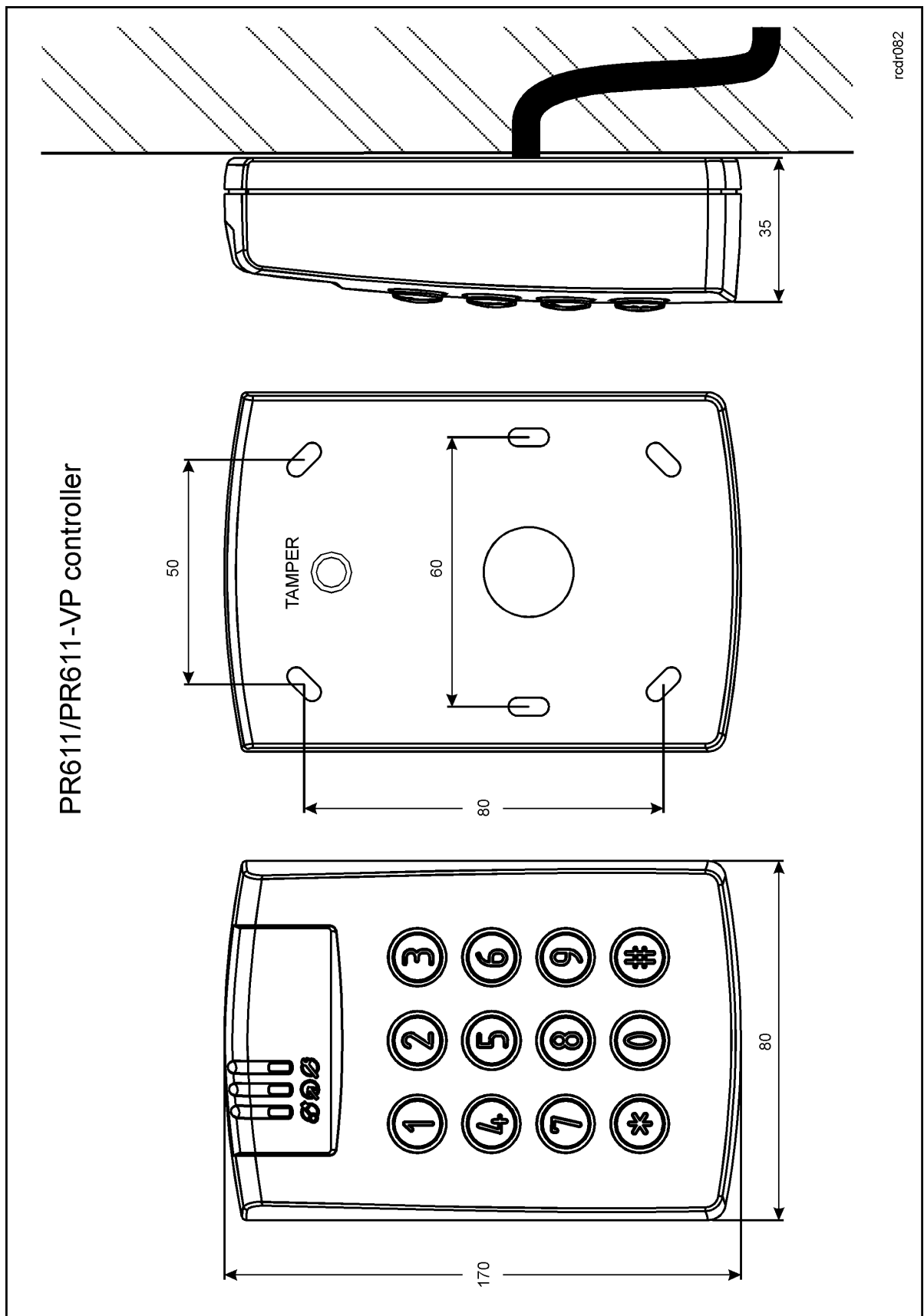

Fig. 3 Installation of PR611 controller



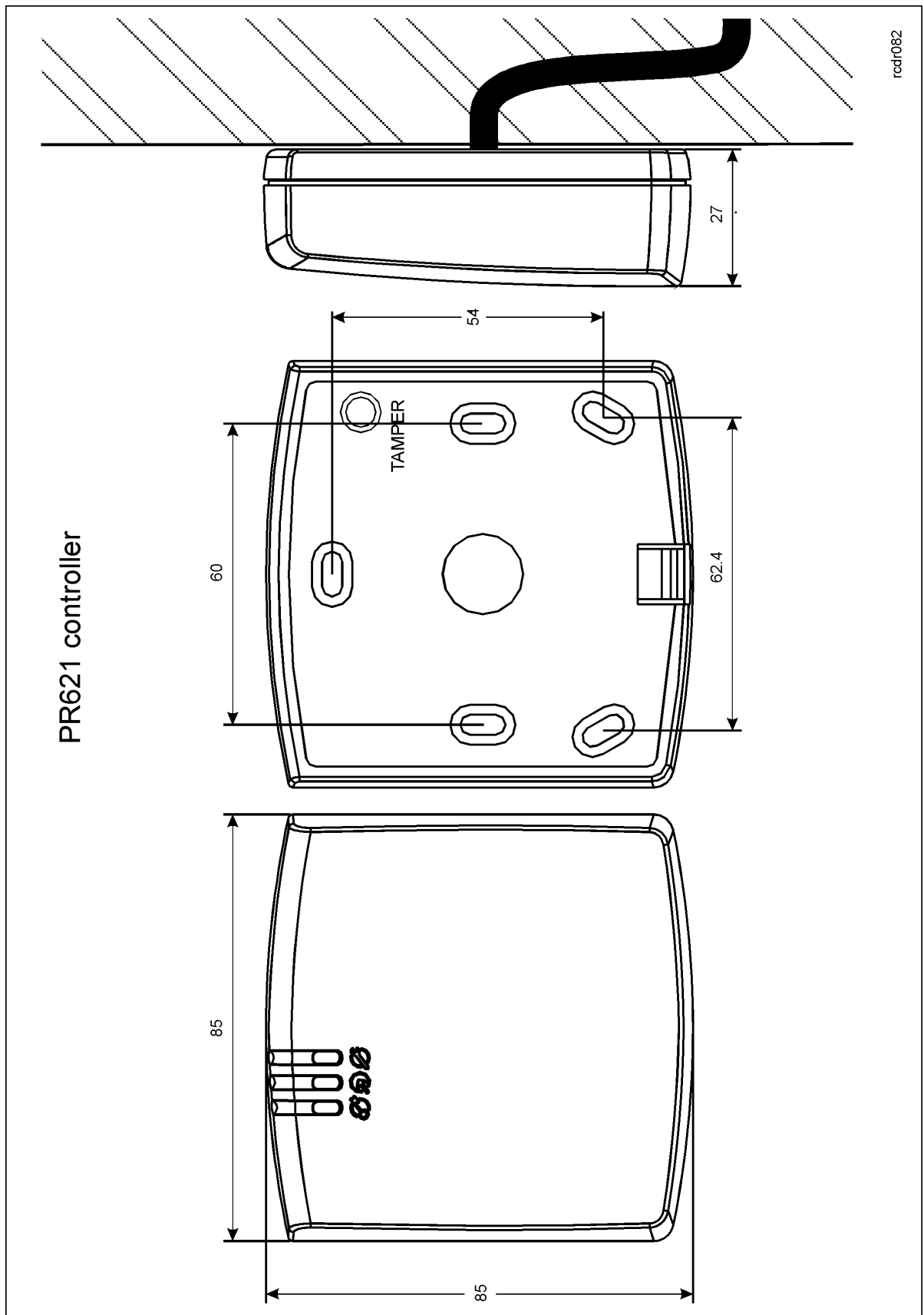

Fig. 4 Installation of PR621 controller

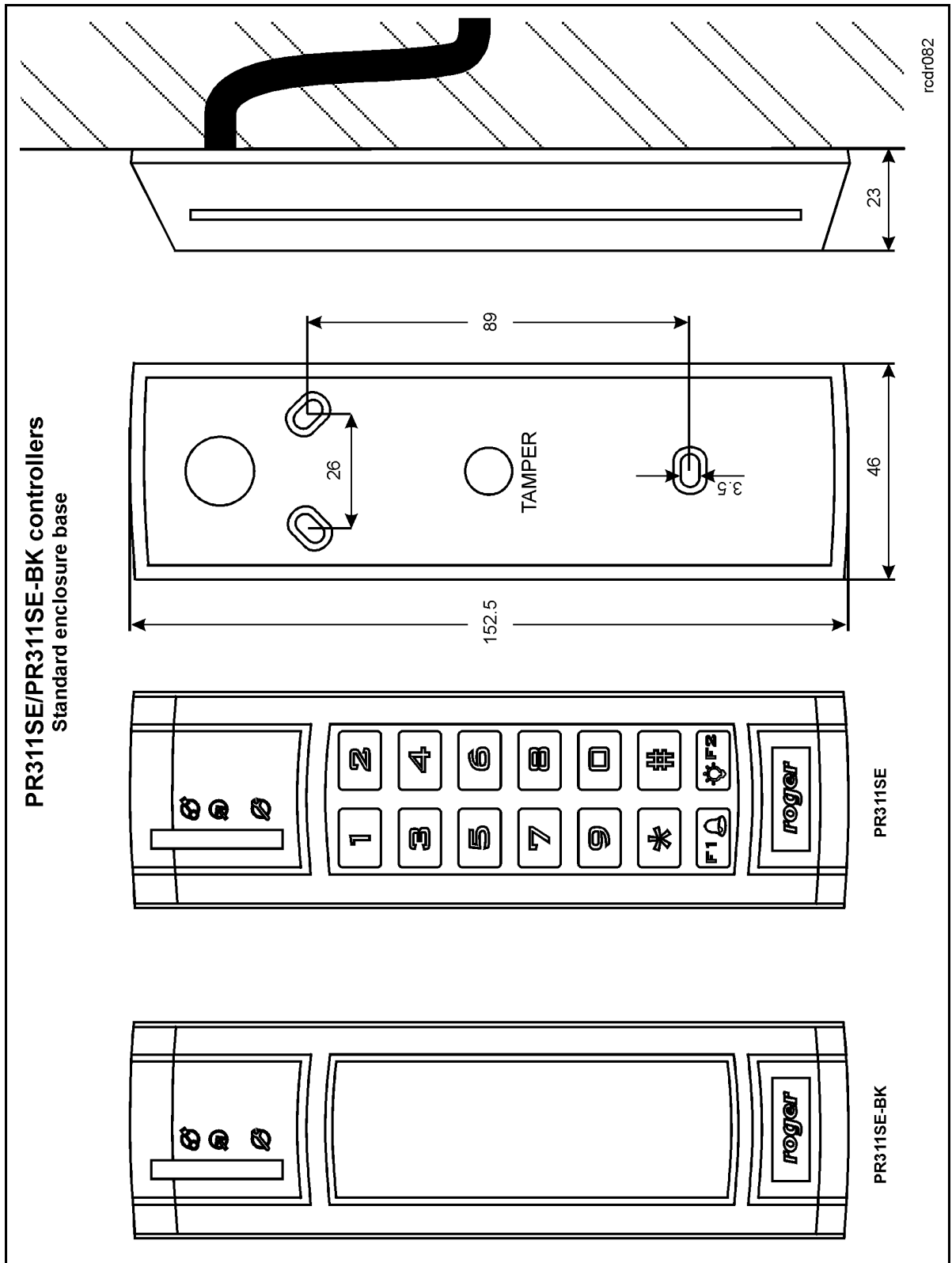

Fig. 5 Installation of PR311SE controller (standard enclosure base)

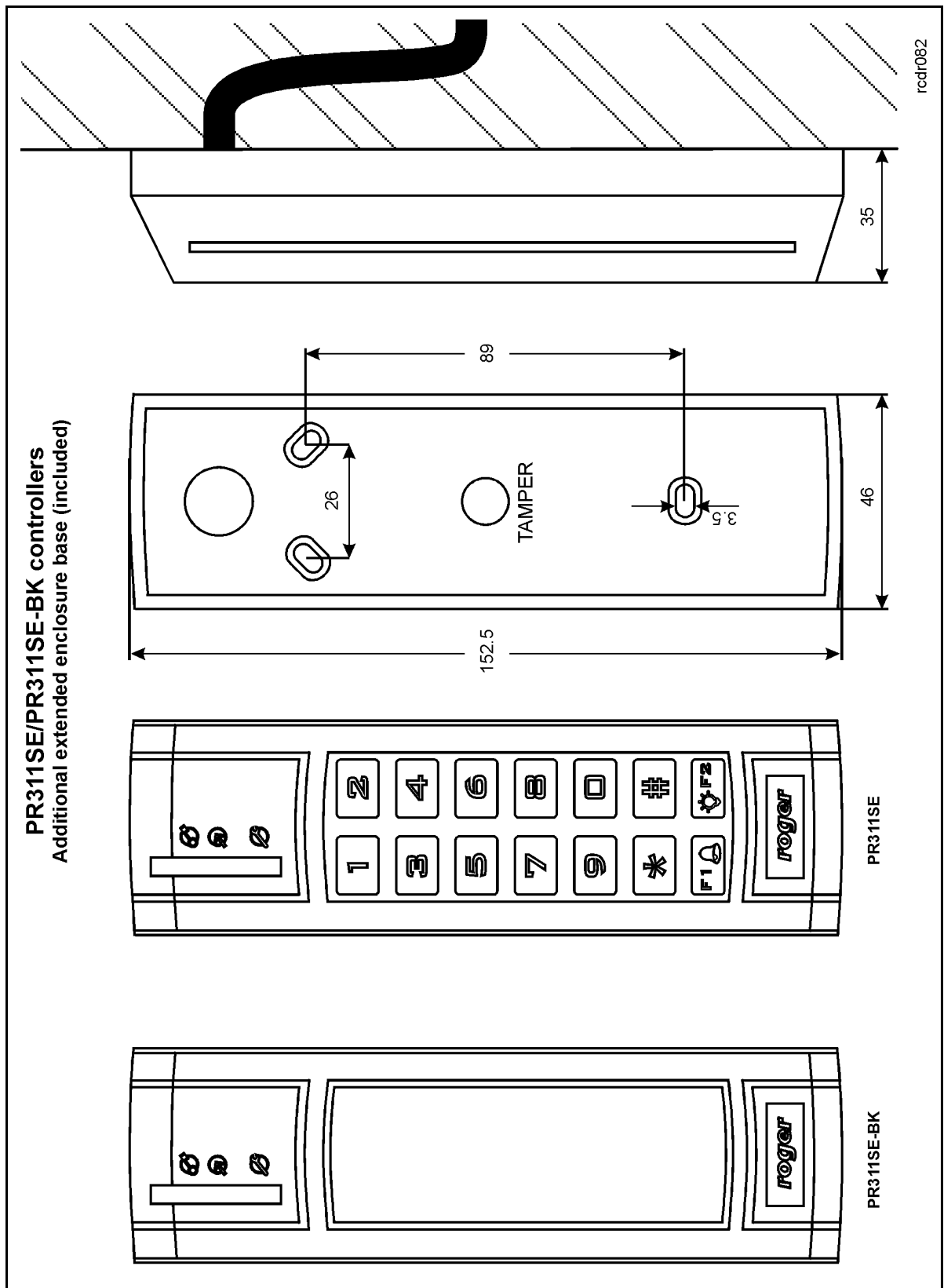

Fig. 6 Installation of PR311SE controller (additional enclosure base)

## 3.9 Installation guidelines

- Install devices in such way as to ensure easy access to screw terminals and jumpers (RST, FDM) located inside the controller – see fig. 7.
- Prior to controller installation it is recommended to configure its address (ID number) – see 4.1 Controller address. Factory default address is ID=00.
- The controller is delivered with MASTER proximity card, however any proximity card in EM 125kHz (UNIQUE) can be programmed as MASTER card.
- The controller should be installed on the wall in the vicinity of the controlled door, in a vertical position.
- All electric connections must be made with power supply switched off.
- All devices connected to the same communication bus (RS485 and RACS CLK/DTA) should be connected to the same negative potential (GND). Therefore all GND terminals from various power supply units used in the system should be connected with each other.
- General purpose diode e.g. 1N4007 should be always connected in parallel and as close as possible to the door locking device (magnetic lock, electric strike, relay, contactor).
- It is required to install readers in minimal distance of 0.5m from each other. If two readers have to be installed on opposite sides of the same wall, it is recommended not to place them directly opposite (in the same axis). If this condition cannot be fulfilled then place metal plate between reader and wall as well as non-metal spacer with 10mm minimal thickness between reader and metal plate.
- Because of relatively low magnetic field readers should not interfere with other devices, however its operation can be disrupted by devices generating strong electromagnetic field.
- If the range of card reading is significantly lower than specified in technical documentation then consider relocation of the reader.
- Readers can be installed on metal surfaces but in such case reduction of reading distance should be expected. The reading distance reduction effect can be minimized by installing readers on non-metal spacer with minimal thickness of 10 mm (e.g. PVC).
- Device can be cleaned by means of wet cloth and mild detergent without abrasive components. In particular do not clean with alcohols, solvents, petrol, disinfectants, acids, rust removers, etc. Damages resulting from improper maintenance and usage are not covered by manufacturer warranty.

## 4. CONFIGURATION

### 4.1 Controller address

If controller works autonomously (standalone mode), then address setting can be skipped and default address ID =00 can be used but if the controller is to be connected with other controllers by means of RS485 bus and operate in network system, then it is necessary to assign unique address to such controller (ID number from range 00..99). Two or more devices with the same address result in communication conflict and make a proper communication with these devices impossible. Following addressing methods are available:

- During update of controller firmware by means of RogerISP software (so called Fixed ID)
- Manually during Memory Reset procedure
- By means of PR Master software
- Manually with command entered from keypad

The first method enables configuration of hardware address while the remaining ones enable configuration of software addresses. The main difference between these two addressing methods is such that software address contrary to hardware address can be modified using any of mentioned methods. Therefore Fixed ID has the highest priority and the other methods have lower priority.

---

Note: A new controller can be connected to the existing system without the necessity to change its address but only if no other controller operates with default address ID=00. Once the controller is connected to the RS485 communication bus, it should be detected by means of PR Master software and new address should be configured.

---

#### 4.1.1 Addressing during firmware update (Fixed ID)

FixedID can be set during update of the controller firmware by means of RogerISP software. Prior to firmware upload, RogerISP software offers the possibility to set Fixed ID address in range of 00..99 or disable it (FixedID=None). Once the FixedID is selected and uploaded to the controller software addressing is ignored. In order to disable or modify FixedID it is necessary to start firmware upload procedure.

---

Note: When FixedID is configured then controller address cannot be modified based on software addressing method. FixedID address is maintained even in case of controller configuration error. Therefore controller can be always detected on the communication bus with the same address by means of PR Master software.

---

#### 4.1.2 Addressing during Memory Reset procedure

Software address can be configured during Memory Reset procedure – see 4.2 Memory Reset procedure.

---

Note: Software address is effective only if FixedID is None.

---

#### 4.1.3 Addressing by means of PR Master software

Software address can be configured by means of PR Master software. In such case connect the controller to PC via communication interface (e.g. UT-2USB, UT-4DR) or via CPR32-NET-BRD network controller, detect the controller and configure the address.

---

Note: Software address is effective only if FixedID is None.

---

#### 4.1.4 Addressing by means of command entered with keypad

All commands for manual programming of controller by means of keypad are specified in the document Functional description of PRxx1 series controllers. Following keypad command can be used for addressing:

[01#][Login][Login][40][2 digits of controller ID address][00#]

The login for above command can be done with included MASTER proximity card.

## 4.2 Memory Reset procedure

Memory Reset procedure erases current settings and restores default factory settings. Additionally Full Memory Reset enables to program new MASTER card/PIN as well as new address of the controller. After Memory Reset procedure the controller automatically enters normal working mode.

---

Note: If current address of the controller is hardware type (see 4.1 Controller address) i.e. FixedID then address selected during Memory Reset procedure is ignored.

---

#### 4.2.1 Simplified Memory Reset Procedure

Simplified Memory Reset restores default settings with controller address ID=00 and enables programming of new MASTER card.

- Remove connections to CLK and DTA lines
- Connect CLK with DTA
- Restart the controller (place and remove jumper on RST contacts – see fig. 7 or switch power supply off/on) – the controller shall switch all LED indicators on and shall generate continuous acoustic signal
- Disconnect CLK and DTA - the controller shall switch all LED indicators off and then LED OPEN  indicator shall pulsate
- Read any card at the controller — this will be the new MASTER card
- After a few seconds the controller shall restart automatically and switch to normal mode

#### 4.2.2 Full Memory Reset procedure



Full Memory Reset restores default settings and enables programming of new MASTER card, MASTER PIN and controller ID address. In case of controller without keypad (PR621 and PR311SE-BK) it is necessary to connect PRT series reader with keypad (e.g. PRT12LT) to perform Full Memory Reset.

- Remove connections to CLK and DTA terminals/wires
- Connect CLK with DTA
- Restart the controller (place and remove jumper on RST contacts – see fig. 7 or switch power supply off/on) – the controller shall switch all LED indicators on and shall generate continuous acoustic signal
- Disconnect CLK and DTA - the controller shall switch all LED indicators off and then LED OPEN  indicator shall pulsate
- In case of controller without keypad (PR621 or PR311SE-BK) connect PRT series reader with keypad (e.g. PRT12LT) to CLK and DTA lines and execute further steps by means of the reader. In case of controller with keypad use its keypad
- Enter new MASTER PIN (3 to 6 digits) followed with the [#] key or skip this step and press only the [#] key
- Read any card at the reader, this will be a new MASTER card or skip this step and press only the [#] key
- Enter two digits (in range of 00 to 99) by means of keypad, this will be new ID address or skip this step and press only the [#] key so the default ID=00 could be assigned
- After a few seconds the controller shall restart automatically and switch to normal mode

#### 4.2.3 Full Memory Reset procedure (controller without keypad)

Full Memory Reset restores default settings and enables programming of new MASTER card and controller ID address using card readings.

- Remove connections to CLK and IN3 terminals/wires
- Connect CLK with IN3
- Restart the controller (place and remove jumper on RST contacts – see fig. 7 or switch power supply off/on) – the controller shall switch all LED indicators on and shall generate continuous acoustic signal
- Disconnect CLK and IN3 – the controller shall switch all LED indicators off and then LED OPEN  indicator shall pulsate
- Read any card at the controller, this will be the new MASTER card. Then the controller shall generate two short acoustic signals
- Read MASTER card X times where X corresponds to the first digit of the required controller ID address. Then wait until the controller generates two short acoustic signals
- Read MASTER card Y times where Y corresponds to the second digit of the required controller ID address. Then wait until the controller generates three short acoustic signals
- After a few seconds the controller shall restart automatically and switch to normal mode

After Memory Reset controller resumes its work with default factory settings and configured address. You can then test its operation using MASTER card or PIN (if available). Using the MASTER card/PIN once activates the REL1 output for 4 seconds (LED OPEN ). Using the MASTER card/PIN twice switches the IO1 output to the opposite state and switches Arm/Disarm Mode (LED STATUS  changes its colour).

### 4.3 Controller programming

Controllers can be configured by means of:

- PR Master software installed on computer connected to the controller via communication interface (e.g. UT-2USB, UT-4DR) or via CPR32-NET-BRD network controller
- Commands entered with controller's keypad

More information on controllers programming can be found in the document Functional description of PRxx1 series controllers as well as in PR Master User Manual which are available at [www.roger.pl](http://www.roger.pl).

## 4.4 Firmware update

The latest versions of firmware and Roger ISP software are available at [www.roger.pl](http://www.roger.pl). In order to update firmware it is necessary to connect the device by means of RS485 bus to communication interface (UT-2USB or RUD-1) and then connect the interface to PC with installed Roger ISP software. It is not necessary to disconnect the controller from access control system, it is only required to place FDM jumper in order to put the device in firmware download mode. Therefore firmware update can be performed by means of RS485 bus of access control system.

### Firmware update procedure

- Place jumper on FDM pins (see fig. 7)

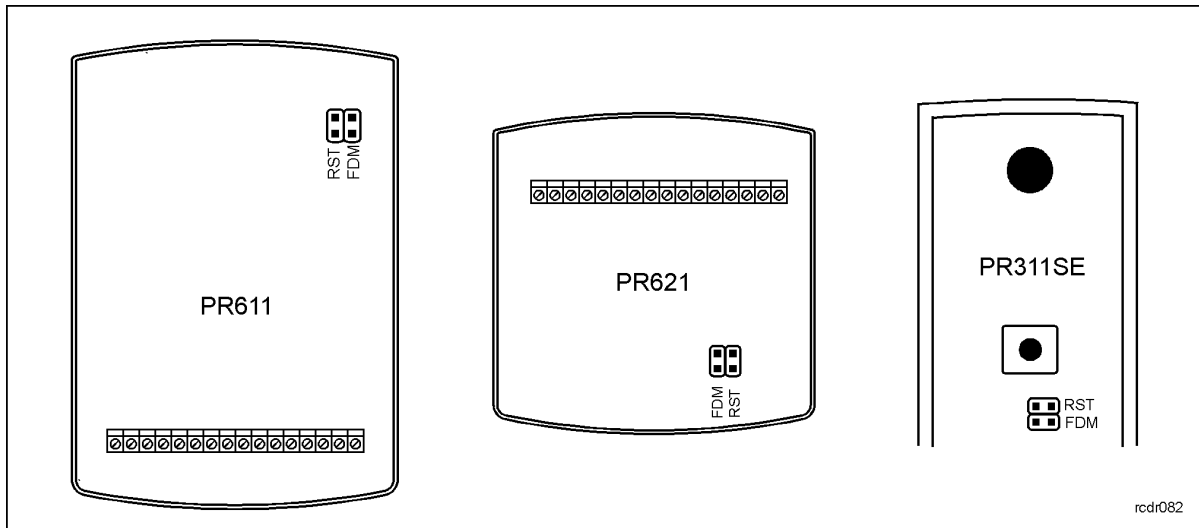



Fig. 7 Location of FDM and RST contacts inside the enclosure of controller

- Reset device (place and remove jumper on RST pins or switch power off/on)
- Start RogerISP software and select communication port (in case of RUD-1 select **USB-RS485 Converter**).
- Press the button **Erase**
- Once more reset device (place and remove jumper on RST pins or switch power off/on)
- In Firmware window select firmware \*.hex file (can be downloaded from [www.roger.pl](http://www.roger.pl)) and then select the button **Program**
- After firmware upload remove jumper from FDM pins and reset device (place and remove jumper on RST contacts or switch power off/on)

Note: If the controller is not responding and LED SYSTEM  (orange) is on after firmware update procedure then it is necessary to perform reset – see 4.2 Memory Reset procedure or update the firmware once more.

Note: In case of network system, it is required to restart controller within PR Master software by right clicking particular controller and selecting the option **Restart controller and verify version**.

## 5. ORDERING INFORMATION

Table 4. Ordering information	
PR611	Access controller with built-in EM 125 kHz (UNIQUE) card reader and keypad.
PR621	Access controller with built-in EM 125 kHz (UNIQUE) card reader.
PR311SE	Access controller with built-in EM 125 kHz (UNIQUE) card reader and keypad.

PR311SE-BK	Access controller with built-in EM 125 kHz (UNIQUE) card reader
CPR32-NET-BRD	Electronic module of network controller
UT-4DR	Ethernet-RS485 communication interface:
UT-2USB	USB-RS485 communication interface:
RUD-1	Portable USB-RS485 communication interface with 12VDC/0.12A output
XM-2DR	I/O expander

## 6. PRODUCT HISTORY

<b>Table 5. Product history</b>		
Product version	Released	Description
PR611/PR621 v.1.0	12/2008	The first commercial version of the product
PR611/PR621 v.2.0	06/2010	Protection of input, outputs and RS485 bus, regulated backlight in PR611
PR311SE v.1.0	07/2006	The first commercial version of the product

	<p>This symbol placed on a product or packaging indicates that the product should not be disposed of with other wastes as this may have a negative impact on the environment and health. The user is obliged to deliver equipment to the designated collection points of electric and electronic waste. For detailed information on recycling, contact your local authorities, waste disposal company or point of purchase. Separate collection and recycling of this type of waste contributes to the protection of the natural resources and is safe to health and the environment. Weight of the equipment is specified in the document.</p>
---	---

**Contact:**  
**Roger sp. z o.o. sp.k.**  
**82-400 Sztum**  
**Gościszewo 59**  
**Tel.: +48 55 272 0132**  
**Fax: +48 55 272 0133**  
**Tech. support: +48 55 267 0126**  
**E-mail: [support@roger.pl](mailto:support@roger.pl)**  
**Web: [www.roger.pl](http://www.roger.pl)**