

Electronic Code Locks

SL2000B v2.0

Document version: Rev. F



Features

- **Bell** output to indicate Door Bell and Door Alarm
- **Bistable/Switch** output to control door locking device
- DC input for detection of door status
- DR input to unlock the door from the external button
- INSTALLER code for programming
- MASTER code switch between armed and disarmed modes
- 55 USER codes for door unlocking
- Programmable length of codes
- User indexing for easy administration of the codes
- Non-volatile memory
- Three LEDs and buzzer
- Tamper
- 12VDC supply
- CE, RoHS

Introduction

The SL2000 electronic code lock is dedicated to operate as a stand-alone door access control unit. It is equipped with one relay output, two transistor outputs and three inputs. All codes and parameters programmed to device are stored in non-volatile memory.

Functional Description

Note: The C1,C2...C10 parameters which appear in this manual refer to the configuration parameters programmed in the SL2000 during **Memory Reset** procedure.

Output

SL2000 has one relay output and two transistor outputs (Switch and Bell).

Relay output

The REL output offers one switched NO/NC contact rated 1.5A/30V AC/DC. This output is activated each time a user code sequence is entered (User code 01..55). Activation takes place after a **C1C2** delay and lasts for the time specified by the **C3C4** parameter. Each time the RELAY switch of SL2000 lock is activated the yellow led **ENTRANCE**  lights up. By using the Main code it is possible to temporary disable/enable activity of all user codes (Disable USER Codes When in Armed Mode).

Open collector outputs

The Switch and BELL outputs of SL2000 lock are an open collector transistor type. Some care must be taken in order to protect them from damage. When transistor output is switched off it remains in high impedance state, when switched on it shorts connected to it potential with supply minus. The maximum current must not exceed 1A and maximum voltage must not exceed 15VDC.

Switch output

Enter the master code each time switches output in the opposite state. This mode is dedicated to control some device or system which requires bistable (latch) control, usually it can be used to control arming mode of the alarm zone or entire alarm system.

The *Status* output can be used for rearming of an alarm zone or to control any other device or system which requires the *ON/OFF* method of control

Bell output

Normally this output remains in high resistance state, if triggered it shorts to supply minus (GND). The Aux output has been designed to indicate two situations:

- Door Bell event
- Door Alarm event

Whenever the Bell key is pressed for a moment or the [#] key is pressed and held down longer than half a second, the Aux output goes steady on (shorts to supply minus), the Aux output remains in this condition as long as the Bell or [#] key is being pressed. The Aux output can be also activated when Door Alarm is active. The code lock indicates the Door Alarm through pulsed modulation of the Aux output. Thanks to this feature (steady or pulsed output) operator may distinguish the Bell signal from the Door Alarm. The maximum current sink by this output is internally limited to 1.0A, the maximum voltage applied to it must not exceed 15VDC. Normally the Aux output is used to trigger some kind of warning device (e.g. alarm siren or buzzer).

Door Alarm

The Door Alarm will occur when:

- door has been opened without entering of a valid USER code
- door has been opened without pressing of the Exit Button
- door has not been closed within designated time defined by the **C5C6** configuration settings

Once started the Door Alarm is indicated by the pulsed signal on BELL output which is accompanied by a the continues acoustic sound generated by the internal buzzer. Pressing any key will cease the acoustic signal – however this does not cancel the alarm indication on the BELL output. The alarm indication on this output disappears when door becomes closed or automatically after 60 seconds from the moment when alarm arose.

Note: The Door Alarm has higher priority than Door Bell. When two of these events occur simultaneously SL2000 indicates Door Alarm only because it has higher priority than Door Bell indication.

Inputs

Input DR: Exit Button

Triggering of this input activates Door Lock (momentary) output on the same rules as entry of the valid USER code. The Exit Button is a NO type input – it becomes triggered when shorted to supply minus (GND).

Input DC: Door Contact

This input is dedicated for the connection of a door open sensor. When input is open or left unconnected the code lock assumes that door is closed, when input is shorted to supply minus (GND) the SL2000 assumes that door is open.

Note: If you are not going to use a door open sensor leave the Door Contact input unconnected. Without a door open sensor the SL2000 will not signal the **Door Alarm**.



Special options

Timed Lock-Out

If this option is enabled the SI2000 disables the keypad for 60 seconds after three attempts of entry of the incorrect code. After this time the SL2000 re-enables the keypad and is ready to accept new keypad's entries. The end of 60 seconds lock-out time is indicated by two series of two beeps (** **).

Disable USER Codes When in Armed Mode

If this option is enabled the SL2000 grants access only when it operates in Disarmed mode. With this option active the access to the controlled door will be totally disabled unless the SL2000 will be switched to Disarmed mode again. Thanks to this formula the MASTER user can disable access to the room by switching the unit to the Armed mode and vice versa, he can re-enable access to the controlled door by switching the lock to the Disarmed mode. The SL2000 can be switched between Armed and Disarmed modes via the MASTER code only.

Note: When the SL2000 is in Armed mode this output remains not active (red **CLOSE LED**  lights up), it become active when lock works in Disarmed mode (green **OPEN LED**  lights up).

Codes

The SL2000 offers three types of codes:

- MASTER Code
- INSTALLER Code
- USER Codes

Each type of code is dedicated for individual purpose. The length of each code can be programmed during Memory Reset procedure. The entry of each code must be followed by the [#] key which is used to mark the end of the code.

MASTER Code

The MASTER code is used to switch the SL2000 between Armed and Disarmed modes, it can be 4-10 digits long.

INSTALLER Code

The INSTALLER code is required to enter the Installer Programming mode, it can be 4-10 digits long.

USER Codes

These codes are used solely to trigger the Door Lock (momentary) output. Each time a valid USER code is entered the SL2000 starts counting **C1C2** time delay and then activates Door Lock output for time defined by the **C3C4** parameters. The USER codes can be 2-8 digits long.

Note: The SL2000 enables programming of maximum 55 USER codes, each of them can be used to trigger Door Lock output.

Commands

Commands can be entered during normal working time of a SL2000 and doesn't require entry to the programming mode.

[USER Code] [#]

Whenever a valid USER code is entered the code lock generates two beeps (**) and then starts count **C1C2** time delay. After it passes SL2000 activates Door Lock (momentary) output for the time defined by **C3C4** settings.

[MASTER Code] [#]

Each time the MASTER code is entered the SL2000 changes its arming mode (switches from Armed to Disarmed mode or in reverse direction).

[INSTALLER Code] [#]

After this command code lock generates two beeps (**) and enters the Installer Programming mode. In this mode installer can manage (add, modify or delete) the USER codes.

[*][Old INSTALLER Code][#][New INSTALLER Code] [#]

This command erases the current INSTALLER code and program a new one. If command is successfully accomplished the unit generates three series of two beeps (** ** **)

[*] [Old MASTER Code] [#][Old MASTER Code] [#]

This command erases the current MASTER code and program a new one. If command is successfully accomplished the unit generates three series of two beeps (** ** **).

Note: Whenever you re-program MASTER or INSTALLER code remember that new code programmed into a unit must have the same length as the old one.

[#]

Normally pressing [#] is used to mark the end of the code but when pressed separately for a time longer the 0.5s it triggers Door Bell indication.

Programming The USER Codes

The SL2000 enables programming of up to 55 different USER codes. The USER codes can be managed (added/deleted/changed) only in the Installer Programming mode (to enter Installer Programming mode press: [INSTALLER Code]+[#]). Once in the Installer Programming mode you have following commands:

[0] [1] [#] [code] [#] ; Programming of the USER code no. 1

[0] [2] [#] [code] [#] ; Programming of the USER code no. 2

... etc.

... etc.

[5] [5] [#] [code] [#] ; Programming of the USER code no. 55

[0] [0] [#] ; Delete all USER codes

[9] [9] [#][code][#] ; Deletes the code entered in square brackets

[#] ; Exit from the Installer Programming mode

When the SL2000 accepts the new USER code it generates two series of two beeps (** **). Any attempt to program the USER code which already exists in the memory or to program it with a wrong length then will cause the programming error signalled by a long acoustic beep.

Configuring the SL2000 – Memory Reset

In order to configure the SL2000 you must perform the Memory Reset procedure and then enrol sequentially 10 digits (C1,C2..C10) which will configure the unit for the individual installation. After the **Memory Reset** the entire code lock memory is erased (including all codes) and initialized with default (factory) settings.

In order to perform **Memory Reset** do the following steps:

1. Turn off the power supply
2. Put the jumper on PZ3 contacts
3. Turn on the power supply
4. Wait till the moment when SL2000 will generate three series of two beeps (** ***) - this signal indicates that unit has erased memory and restored default configuration parameters
5. Remove jumper from PZ3 contacts
6. Enter sequentially ten digits from **C1** to **C10**
7. Once the last digit (**C10**) is entered the code lock generates three series of two beeps (** ***) and automatically switches to normal work (it enters Armed mode).

Meaning of the configuration parameters: C1-C10

C1C2: Specifies the time delay from a moment when USER code is entered till moment when Door Lock output will be triggered. It can be programmed from 00 to 99s (default: 04).

C3C4: Specifies the time for which Door Lock output will be activated. It can be programmed from 02 to 99s (default: 04).

C5C6: Specifies the time within door must be closed otherwise Door Alarm will occur. The **C5C6** time is started from the moment when C4C4 time has passed by. It can be programmed from 00 to 99s, the 00 value sets unlimited time for door closing (default: 09).

C7: Enables or disables of reprogramming of the MASTER and INSTALLER codes, enter 0-3 (default: 0).

C7	Reprogramming of the MASTER code	Reprogramming of the INSTALLER code
0	Enabled	Enabled
1	Disabled	Enabled
2	Enabled	Disabled
3	Disabled	Disabled

Note: If reprogramming of a given code is disabled the SL2000 allows you for a single attempt only to program of the given code. Once the code is programmed, you will not be able to change it unless the **Memory Reset** is carried out. Use this function to disable the end user to change your MASTER and INSTALLER code.

C8: Enabling and disabling special options, enter 0-3 (default: 0).

C8	Option 1: Timed Lock-out	Option 2: Disable USER Codes When in Armed Mode
0	Disabled	Disabled
1	Enabled	Disabled
2	Disabled	Enabled
3	Enabled	Enabled

C9: Defines the length of the USER codes, enter 0-3, (default: 1).

- 0 : USER codes are 2 digits long
- 1 : USER codes are 4 digits long
- 2 : USER codes are 6 digits long
- 3 : USER codes are 8 digits long

C10: Defines the length of the *MASTER* and *INSTALLER* codes, enter 0-3, (default: 1).

- 0 : Both codes are 4 digits long
- 1 : Both codes are 6 digits long
- 2 : Both codes are 8 digits long
- 3 : Both codes are 10 digits long

If an illegal operation occur during Memory Reset the device will signal an error (long beep) and will return to the beginning of the programming so you can start to enter the C1-C10 digits once again. The Memory Reset procedure automatically comes to an end when the last (C10) digit is entered. The device stores the configuration as well as all codes in a non-volatile memory which can be reprogrammed whenever required. After the Memory Reset procedure comes to an end all codes are set to factory default values.

Example:

The following digits C1-C10 were entered during the Memory Reset procedure: [0][0][0][5][3][3][0][0][1][0]. This sequence sets the following options:

- Delay before Door Lock open: 00 seconds
- Door Lock open time: 05 seconds
- Time to close the door: 33 seconds
- Reprogramming of the MASTER code: enabled
- Reprogramming of the INSTALLER code: enabled
- Option 1 (Timed Lock-out): off
- Option 2 (Disable USER Codes When in Armed Mode): off
- USER codes length: 4 digits
- MASTER and INSTALLER codes length: 4 digits

Default settings

After the Memory Reset is accomplished SL2000 restores following codes:

MASTER Code

All digits are "1" (1111...), the length of the code depends on the C10 parameter entered later during Memory Reset procedure.

INSTALLER Code

All digits are "2" (2222...), the length of the code depends on the C10 parameter entered later during Memory Reset procedure.

USER Code no01

All digits are "3" (3333...), the length of the code depends on the C9 parameter entered later during Memory Reset procedure.

All USER codes 02..55

All USER codes no 02 -55 are blank (they doesn't exist).

Installation

- The SL2000 code lock should be mounted near the supervised door on a vertical piece of supporting structure.
- Assure that the surface beneath of the controller's rear panel is flat and smooth.
- Disconnect power supply before making any electrical connections.
- Once installed and electrically connected, the unit has to be properly programmed.
- When forgotten, MASTER and INSTALLER codes can be restored to their default values and then programmed again.
- Use separate pair of wires to supply door lock and SL2000 code lock.
- It is forbidden to supply the door lock directly from the DC input terminals of the code lock.
- Always add the silicon diode (e.g. 1N4007) in parallel to the door lock, note that diode must be located as close as possible to the door lock terminals.
- Do not attempt to use REL1 output for switching of voltages higher then 24V DC/AC.

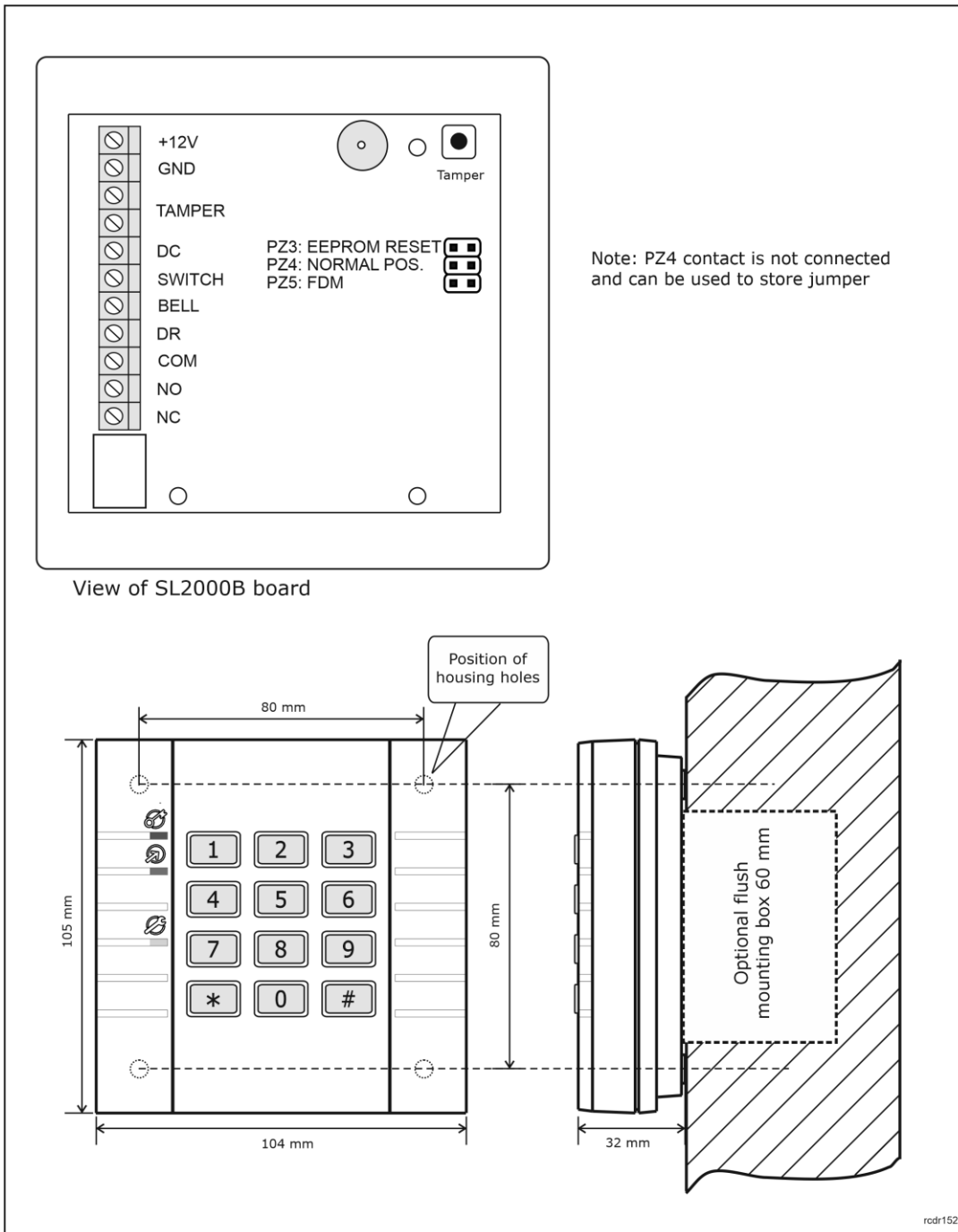
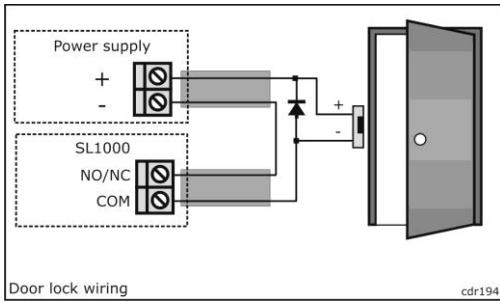

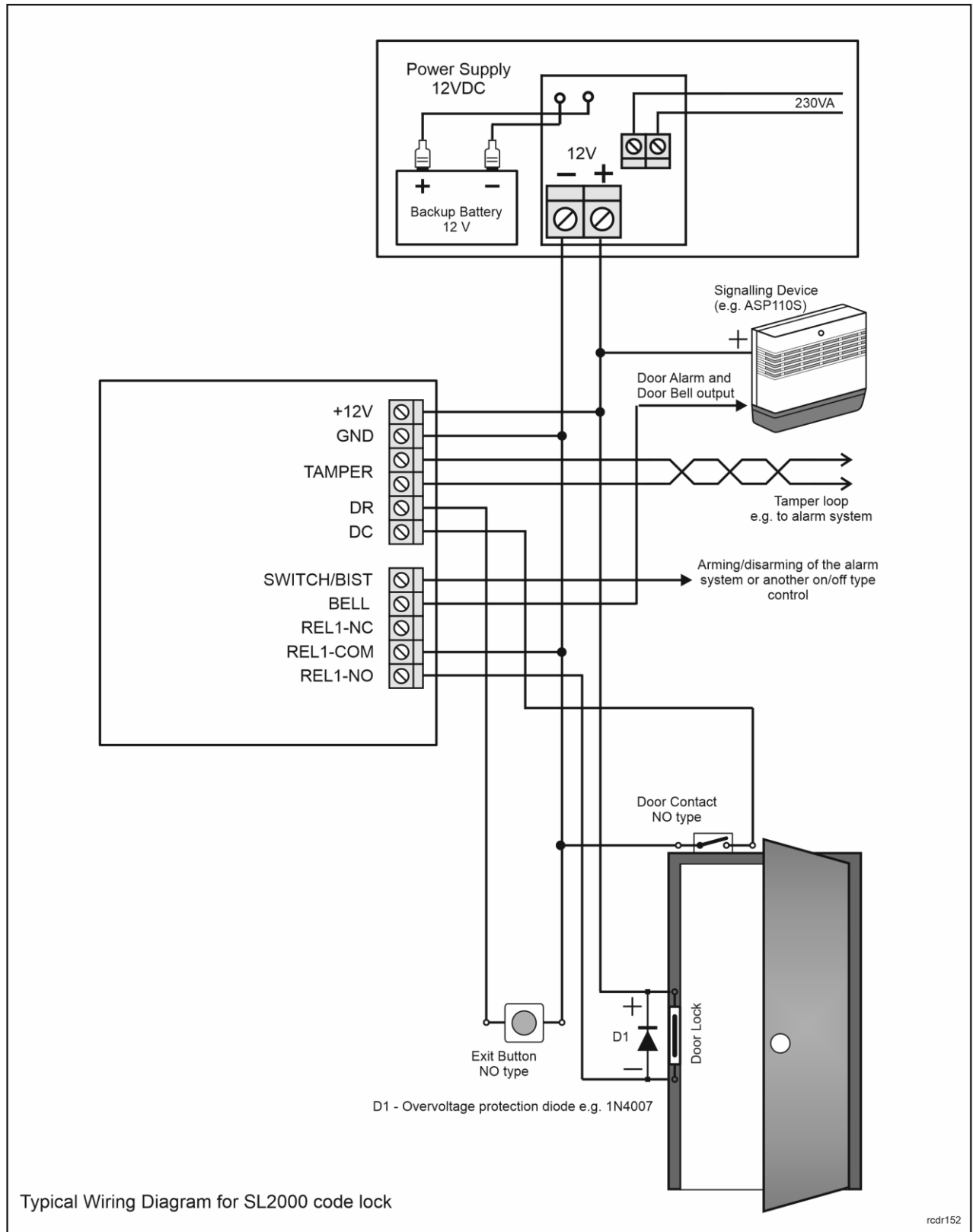

Typical Wiring Diagram for SL2000 code lock

Connection assignments

Label	Description
+12V	Supply input plus
GND	Supply input minus
TAMPER	Tamper contact, NC max. 50mA/24V DC/AC
DR	Exit Button input, NO type
DC	Door Contact input, NO type, 1.5A/24V DC/AC
BELL	Transistor output, 1A/15V DC
SWITCH	Transistor output, 1A/15V DC
REL-COM	Relay output, 1.5A/24V DC/AC
REL-NO	
REL-NC	

Technical Specification

Parameter	Value
Nominal power supply	12VDC
Nominal current consumption	25 mA Max. 80 mA @ 12V DC with relay output active
Anti-sabotage protection (Tamper)	NC contact, 50mA/24V
Operational environment	Indoor, temp.: - 10°C +40°C, relative humidity: 0 - 75%
Dimensions W x S x G	105 X 104 X 30 mm
Weight	130g
Compliance	CE, RoHS

Ordering Information

Item	Description
SL2000B	Plastic enclosure, indoor installation only

Product History

Version	Firmware	Date	Description
SL2000B v1.4	N/A	07/2011	
SL2000B v2.0	N/A	05/2020	Modifications of electronic components

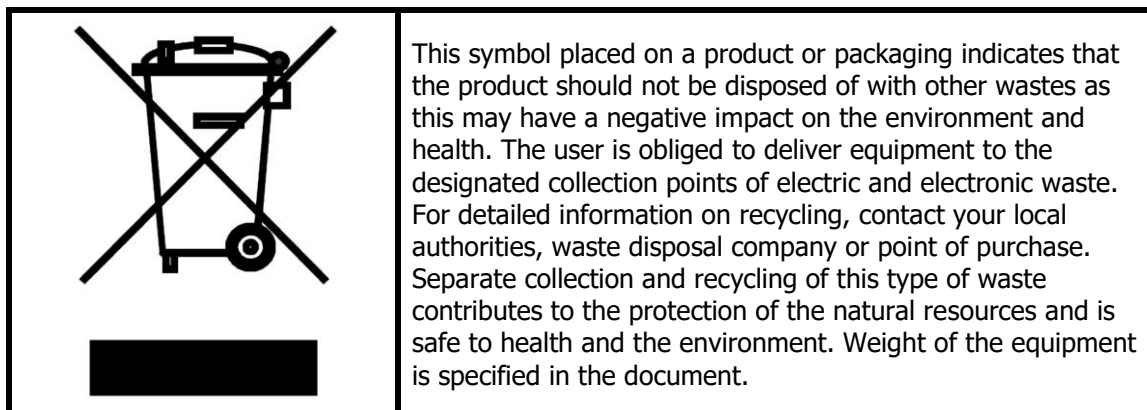
**Contact****Roger sp. z o. o. sp. k.****82-400 Sztum****Gosciszewo 59****Tel.: +48 55 272 01 32 Fax: +48 55 272 01 33****Technical support PSTN: +48 55 267 01 26****e-mail: support@roger.pl****Web: www.roger.pl**