

PRTxxEM series EM125 kHz readers

Firmware version: x.35.xxx

Document version: Rev. T



This document refers to following products:

- *PRT12EM*
- *PRT12EM-BK*
- *PRT62EM*
- *PRT64EM*
- *PRT64EM-VP*
- *PRT66EM*

Operating Manual

1. GLOSSARY OF TERMS 4

2. IMPORTANT NOTES 5

2.1. Compatibility Rules 5

2.2. About This Manual 5

3. GENERAL DESCRIPTION 5

3.1. Features 6

3.1.1. General 6

3.1.2. Terminal Mode (Online Mode)..... 6

3.1.3. Standalone Mode (Offline Mode)..... 6

3.2. Proximity Cards 7

3.2.1. T5555 and T5557 Cards..... 7

3.3. Function Keys 7

4. OPERATING MODES..... 7

4.1. Terminal Mode (Online Mode) 7

4.1.1. Wiegand Formats 8

4.1.2. Magstripe Formats..... 8

4.1.3. RACS Format 8

4.1.4. RS232, EPSO Protocol (9600, N, 8, 1) 9

4.1.5. RS232, PINs transmitted as separate digits (9600, N, 8, 1) 9

4.1.6. RS232, PINs transmitted as whole numbers (9600, N, 8, 1)..... 9

4.2. Standalone Mode (Offline Mode) 10

4.2.1. Full Standalone Mode 10

4.2.2. Simple Standalone Mode..... 11

5. STANDALONE MODE..... 11

5.1. Users 11

5.1.1. Managing the Users 12

5.1.2. User Identification 12

5.2. Door Unlocking 12

5.3. Facility Code 12

5.4. Arming Modes..... 13

5.4.1. Arming/Disarming Methods 13

5.5. Door Bell Function 16

5.6. Function Keys 16

5.7. Door Alarm	16
5.8. Tamper Alarm	17
5.9. Intruder Alarm	17
5.10. Duress Alarm	17
5.11. General Alarm	17
5.12. Events Recording	17
5.13. Real Time Clock	19
5.14. Timers	19
5.15. Optical and Acoustic Signals	20
5.16. Operation with XM-2 I/O Expander	21
5.17. Operation with Second PRT Series Reader	21
6. PROGRAMMING	21
6.1. Programming of Readers without Keypad	22
6.1.1. Programming Through Multiple Readings of the Programming Card	22
6.1.2. Programming From The External Reader	22
6.2. Memory Reset	23
7. OPERATING MODES	24
8. INSTALLER PROGRAMMING	28
8.1. Programming commands	28
8.2. Input/output Functions	31
9. USER PROGRAMMING MODE	33
9.1.1. User Programming Commands	34
10. PROGRAMMING FROM PC	36
10.1. Programming via RS232 COM port	36
10.2. Programming via RUD-1 interface	36
10.3. Firmware Upgrade	37
10.3.1. Firmware upgrade via RS232 COM port	38
10.3.2. Firmware upgrade via RUD-1 interface	38
11. INSTALLATION GUIDELINES	39

1 . G L O S S A R Y O F T E R M S

Door Release or Door Lock

Electric device used to lock/unlock a door. Typically it can be a door strike, solenoid lock or magnetic lock.

Identifier

The physical item or method which is used for identification of users. It can be a proximity card, a PIN code, a finger template etc. In some cases identifier may consist of two or more items required for a single identification procedure. For example when option **Card and PIN** is active then Identifier=Card+PIN.

Identification Mode

The method used for identification of users, it can be **Card or PIN, Card and PIN, Card only, PIN only** etc.

Memory Reset

The procedure which clears contents of device's memory and restores default (factory) settings.

PRT Series Readers

The PRT reader's family developed and manufactured by Roger.

Restart

The situation when device goes through the initialization procedure, the same as when it is powered up.

Roger Access Control System (RACS)

The access control system which consists of PR series access controllers developed and manufactured by Roger.

Access Control Unit (ACU)

The logic device which provides access control, usually it is an access controller.

XM-2 I/O Expander

The remote I/O expander for RACS system. The XM-2 provides two NO/NC inputs and two relay outputs.

Full Standalone Mode

The operation mode in which reader autonomously controls a door. When operating in **Full Standalone Mode** the PRTxxEM reader requires the remote XM-2 expander, also in this mode it can operate with another (second) PRT series reader to provide read-in/out door control.

Simple Standalone Mode

The operation mode in which reader independently controls a door. When in **Simple Standalone Mode** the PRTxxEM reader uses its internal I/O lines as general purpose I/Os but is not capable to operate with XM-2 expander and/or second PRT series reader.

RACS Interface

The electrical interface and addressable protocol developed by Roger. This interface is implemented in access readers and controllers manufactured by Roger. The RACS interface uses two communication lines (CLK and DTA) and proprietary communication protocol capable to address up to 16 devices.

EPSO Protocol

The addressable, half duplex, serial communication protocol developed by Roger. This protocol allows a host device (PC or controller) for direct control of the reader's hardware through the set of remote commands.

RARC Program

This program enables programming and maintenance of the PRT series reader which are equipped with serial communication interface.

RogerISP Program

This program enables firmware upgrade in access controllers and readers manufactured by Roger.

2 . I M P O R T A N T N O T E S

The PRTxxMF reader can be configured for several operating modes however the factory shipped unit is pre-configured for **[030] Offline mode, Simple Standalone**. The operating mode can be changed:

- Manually within Memory Reset procedure
- Remotely from computer with RARC program

The PRTxxMF reader in standalone (offline) operating mode can be further programmed:

- Remotely from computer with RARC program
- Manually from the keypad located on primary reader (when available)
- Manually from the keypad located on secondary reader (when available)
- Manually by multiple readings of the **Programming Card**

In case of manual programming in standalone operating mode, it is necessary to use MASTER and INSTALLER users. Each of them can have card and/or PIN. The reader is offered with preprogrammed MASTER card but any EM125kHz standard cards can be programmed as MASTER and INSTALLER within Memory Reset procedure.

Note: If after power up the LED SYSTEM  (orange) is on it and the reader makes regular sounds then it means that reader's memory is corrupted. In this case reader must be programmed again or returned to default settings with Memory Reset procedure.

2.1. COMPATIBILITY RULES

Always check the firmware and hardware version for which manual is dedicated. Using wrong version of manual may cause that device will not behave as described in document.

Also, when you upgrade firmware in the reader assure that the new firmware is dedicated for given type of reader (it must be clearly stated that given firmware is dedicated for given type of product you have). Once the firmware is uploaded use adequate manual for the upgraded device.

2.2. ABOUT THIS MANUAL

This manual is dedicated for all versions of PRTxxEM readers - with keypad and without keypad. Each PRTxxEM reader regardless of built-in keypad represents the same logical functionality. The only difference between various types of PRTxxEM series readers is limited to their mechanical construction, environment in which they can be installed and keypad which is available in some of PRTxxEM readers. Therefore, the same configuration settings can be used to program various versions of PRTxxEM readers. Additionally, RARC program configuration settings can be transferred (copied) between different versions of PRTxxEM readers.

Theoretically, it is possible to program and use PIN codes and other functions related with keypad on PRTxxEM reader which is not physically equipped with keypad however it has practical application only when such reader is operated in **Full Standalone Mode** and it is connected with another (second) PRT reader which has built-in keypad. In such scenario users can use keypad to enter commands (including PIN codes) on the second (slave) reader.

When PIN codes are programmed into reader without keypad it is obvious that they cannot be used on this individual reader however still they will exist in configuration settings of this particular unit and can be transferred from the reader to PC and then to another PRTxxEM reader.

3 . G E N E R A L D E S C R I P T I O N

The PRTxxEM readers are designed for use in access control installations to enable user identification via EM 125 KHz (and compatible) proximity cards and/or PIN-s.

Readers can be configured for Standalone Mode (**Offline Mode**) or Terminal Mode (**Online Mode**) when they are connected to the external access control unit (ACU) supporting compatible data interface formats.

When configured for standalone operation PRTxxEM reader independently (i.e. autonomously) controls the supervised door access point. For this mode reader offers two variants of installation: first of them uses the reader's built-in I/O signal lines as programmable inputs and outputs, the second one uses them for communication with external XM-2 expander and secondary (optional) PRT series reader. An access control installation including two PRT readers (one at the entry and other at the exit side of the supervised door) enables read-in/out door control. Also, the system setup utilizing the XM-2 expander provides higher level of security for the entire door access control system by separating its logical element (reader) from the relay which physically controls door lock.

The PRTxxEM reader configured for **Online Mode** works as a slave unit for the purpose of reading cards/PIN-s then providing subsequent transmission of such collected data to host ACU for further processing. Reader offers several data transmission formats including popular Wiegand and Magstripe data protocols.

The PRTxxEM reader can be also used to program T5555 (Q5) and T5557 type cards using RARC software.

3.1. FEATURES

3.1.1. General

- EM 125 KHz proximity cards (EM4100/4102 compatible)
- Programmable T5555 (Q5) and T5557 card numbers
- Tamper switch (detection of enclosure opening and detachment)
- Configurable as standalone access unit or slave reader
- Outdoor installation (depends on particular reader)
- Programming and firmware upgrade through RS232 serial port
- RARC configuration program (for Windows)

3.1.2. Terminal Mode (Online Mode)

- 26/32/32 reversed/34/42/66 bit Wiegand data formats
- Magstripe data format (ABA Track II emulation)
- RACS CLK/DTA (for communication with Roger controllers)
- RS232, EPSO protocol
- RS232, direct output of cards and keys
- RS232, direct output of cards and PIN-s
- Various options for transmission of PIN-s and keys
- LED control input
- BUZZER control input

3.1.3. Standalone Mode (Offline Mode)

- System settings stored in non-volatile memory
- 120 indexed users with card and/or PIN-s
- User indexing (indexed user records)
- **Card or PIN** or **Card and PIN** identification modes
- Real time clock (100 year)
- Automatic winter/summer time change
- 1000 event log
- Built-in 1.5A relay output
- Support for door contact and exit button
- Read-in/read-out door control (requires second PRT reader)
- Door Alarm and Door Bell signalling
- Integration with the alarm system through I/O-s
- Operation with XM-2 I/O expander (**Full Standalone Mode**)

3.2. PROXIMITY CARDS

The PRTxxEM was designed for EM 125 KHz proximity cards compatible with EM 4100/4102 transponders. When in online mode reader returns card number without check sum bits. Card number is transmitted starting from the LSB to MSB and if required (it depends on the data output format selected for the given reader) can be supplemented with leading zeros or reduced on the MSB positions.

3.2.1. T5555 and T5557 Cards

The T5555 (Q5) and T5557 cards are special type of EM cards which can be programmed. Using any PRTxxEM reader together with RARC program it is possible to read and write card's Chip Serial Number.

3.3. FUNCTION KEYS

Some of the PRTxxEM series readers are equipped with one or two function keys: [F1] with door bell icon and [F2] with the light bulb icon. The function of each function keys depends on the reader's operating mode and its configuration.

When in RACS Mode, pressing function key will cause transmission of the relevant code to the host controller which can further take adequate action (e.g. trigger door bell, light etc.). The host's reaction for function key always depends on its configuration.

When in Wiegand or Magstripe modes, pressing the F1/F2 causes following codes to be sent over the output lines:

For Wiegand:

- F1=C hex
- F2=D hex

For Magstripe:

- F1=FF FF FF FF BC hex (1099511627708 dec)
- F2=FF FF FF FF BD hex (1099511627709 dec)

When PRTxxEM operates in standalone mode (either **Full Standalone** or **Simple Standalone**) by default the F1/F2 keys work as door bell buttons however they can be also configured to control AUX1/AUX2 outputs. Additionally, in **Full Standalone Mode** function keys on secondary reader (if available) have the same functions as assigned for function keys on main reader even when the main reader has no keys at all.

4 . O P E R A T I N G M O D E S

There are two main modes of operation available for the PRTxxEM reader:

- Terminal Mode (Online Mode)
- Standalone Mode (Offline Mode)

4.1. TERMINAL MODE (ONLINE MODE)

In this mode the reader operates as a slave unit connected to the external access controller. In Terminal Mode reader transmits collected data (card or PIN) to the host for further processing. The PRTxxEM offers following data transmission formats:

- Wiegand 26bit
- Wiegand 32bit, normal mode (from MSB to LSB)
- Wiegand 32bit, reverse order (from LSB to MSB)
- Wiegand 34bit
- Wiegand 42bit
- Wiegand 66bit
- Magstripe (ABA Track II emulation, also called Clock & Data)
- RACS CLKD/DTA (addressable format for communication with Roger controllers)
- RS232, EPSO protocol (transactional protocol, reader responses commands received from the host)
- RS232, cards and individual keys
- RS232, cards and PIN-s

4.1.1. Wiegand Formats

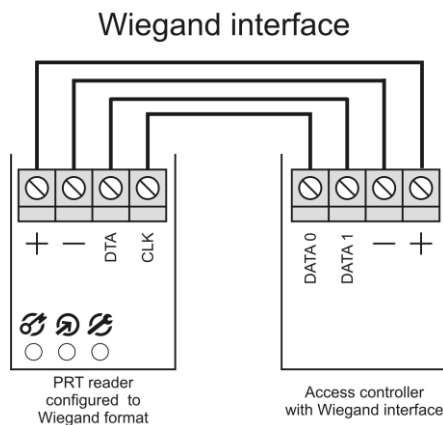

When using **Wiegand** transmission format, data is transmitted to the host via CLK and DTA lines. Depending on the selected version of the transmission format, the reader can send 26, 32, 34, 42 or 66 bits to the host. PIN can be transmitted as a whole (when # key is pressed) or each digit separately – see section 7.

In **Wiegand** format all LED indicators and buzzer of the reader can be controlled by IN1 and IN2 inputs. Both inputs (IN1 and IN2) are triggered by shorting them to supply minus. Input functions can be configured within Memory Reset procedure or with RARC software. In addition, whenever card is read or PIN is entered reader activates momentary LED SYSTEM and buzzer.

Wiegand transmission is unidirectional and data is sent to host device without receipt confirmation.

Note: For card codes which require more bits than the number of bits available in the selected data transmission format, reader omits the most significant bits (MSB-s) of the card code. As a result transmission from a reader is not equal to the full card code.

4.1.2. Magstripe Formats

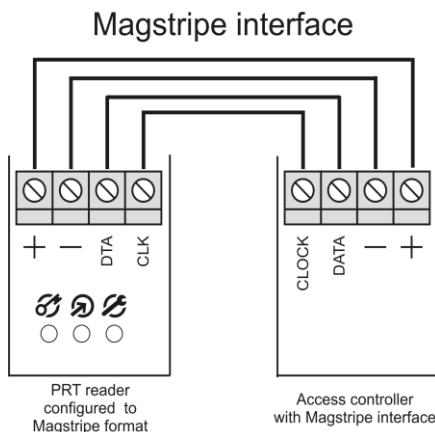

When using **Magstripe** transmission format, data is transmitted to the host via CLK and DTA lines. In **Magstripe** format all LED indicators and buzzer of the reader can be controlled by IN1 and IN2 inputs. Both inputs (IN1 and IN2) are triggered by shorting them to supply minus. Input functions can be configured within Memory Reset procedure or with RARC software. In addition, whenever card is read or PIN is entered reader activates momentary LED SYSTEM and buzzer.

Card code is always transmitted as a whole number (no digits are lost) while PIN can be transmitted as a whole (when # key is pressed) or each digit separately – see section 7.

4.1.3. RACS Format

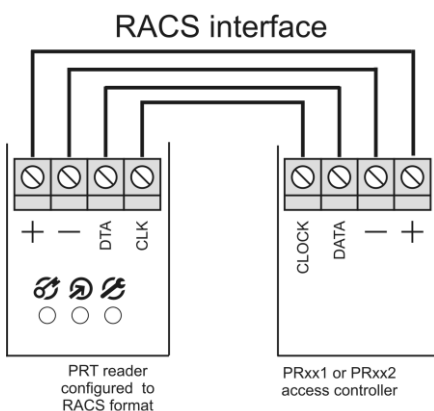

When using **RACS** format, the PRTxxEM reader communicates with the access controller via CLK/DTA lines. Unlike in the Wiegand and Magstripe formats, the PRTxxEM unit using **RACS** format requires an individual address (ID=0...3) to be set during configuration of reader's operating mode (Memory Reset procedure or RARC software). In **RACS** format, communications between the PRTxxEM reader and the host is bidirectional which allows the controller to monitor the communication. The reader's LED-s and the buzzer are controlled by the host unit. When all LED-s are flashing it indicates that reader lost communication with the host unit.

When in **RACS** mode triggering of the IN1 disables reading of the card and keypad. This input can be used for temporary disabling of the reader. The IN2 is not used in **RACS** mode. PIN is transmitted as a whole when # key is pressed.

4.1.4. RS232, EPSO Protocol (9600, N, 8, 1)

When programmed to this protocol reader operates in transaction mode, i.e. responds only to external commands received through the RS232 port. The software developer or system integrator must incorporate EPSO protocol into the host device (usually PC or microcontroller) to communicate with the reader.

In **RS232 EPSO** reader answers only those data packets which come from the host unit and are addressed with reader's ID number (address). The **EPSO** protocol is the set of communication functions used to control the reader's hardware (inputs, outputs, LED-s, buzzer, keypad and reading of cards). The PRTxxEM configured for **EPSO** mode acts as pure "terminal", it means that it strictly follows commands received from the host unit.

4.1.5. RS232, PINs transmitted as separate digits (9600, N, 8, 1)

Once the card is read or key is pressed reader transmits card/PIN data on TXD line. Reader transmits card code as 10 hex number while each pressed key is transmitted separately as 2 hex coded ASCII characters.

Output Format for Cards				
STX	DATA	CR	LF	ETX
02 hex	10 hex digits coded ASCII	0D hex	0A hex	03 hex

Output Format for Keys				
STX	DATA	CR	LF	ETX
02 hex	2 hex digits coded ASCII	0D hex	0A hex	03 hex

Key Codes														
Key	0	1	2	3	4	5	6	7	8	9	*	#	F1	F2
Code	F0	E1	D2	C3	B4	A5	96	87	78	69	5A	4B	3C	2D

4.1.6. RS232, PINs transmitted as whole numbers (9600, N, 8, 1)

Once the card is read or [#] key is pressed then the reader transmits card/PIN data on TXD line. ([#] key is treated as PIN final digit and it is not transmitted). Reader transmits card code as 10 hex digit number and PIN code is transmitted as whole number max. 16-digit long.

Output format for cards				
STX	DATA	CR	LF	ETX
02 hex	10 hex digits coded ASCII	0D hex	0A hex	03 hex

Output format for PIN-s					
STX	DATA	#	CR	LF	ETX
02 hex	16 hex digits coded ASCII	23 hex	0D hex	0A hex	03 hex

The [*], [F1] and [F2] keys are transmitted in this format in the same way as PIN-s:

[*]: STX / 'A' / '#' / CR / LF / ETX

[F1]: STX / 'C' / '#' / CR / LF / ETX

[F2]: STX / 'D' / '#' / CR / LF / ETX

4.2. STANDALONE MODE (OFFLINE MODE)

There are two standalone modes of operation available for the PRTxxEM reader:

- Full Standalone Mode
- Simple Standalone Mode

In both modes reader is capable of providing independent (i.e. autonomic) control of a single door.

4.2.1. Full Standalone Mode

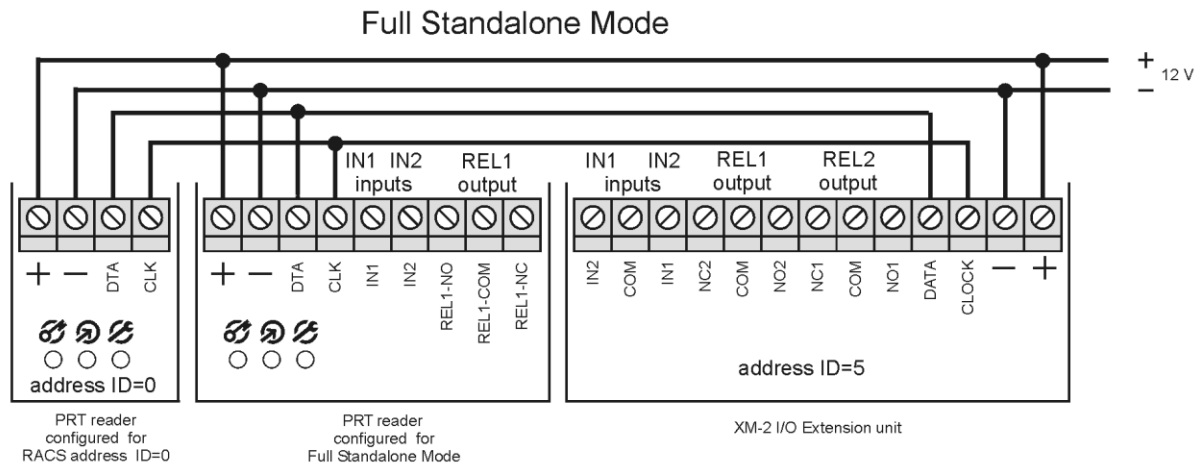

rcdr056

In this mode the CLK and DTA lines are used for communication with the remote XM-2 I/O expander and the second (optional) PRT reader. The second reader enables read-in/out door control and it can also be used for manual programming of the main reader. Each I/O line (built-in or located on expander) can be configured with various functions. The **Full Standalone Mode** offers improved security, because it separates the reader from the relay which is used to control a door lock or other type of equipment. In **Full Standalone Mode** the optical and buzzer signals occur simultaneously on both readers. This rule is valid for programming mode and normal operation as well.

The maximum length of the cable run between the PRTxxEM reader and the XM-2 expander, or secondary PRT reader is limited to 150m. For read-in/out door control the primary reader needs to be configured for **Full Standalone Mode** while the secondary one (slave) needs to be set for **RACS address ID=0**.

Note: For **Full Standalone Mode** the XM-2 I/O expander has to be configured with address ID=5.

Note: Any PRT series reader can communicate with PRTxxEM reader. It is not relevant if such PRT reader is equipped with keypad. It is also possible to connect readers with different card formats e.g. PRTxxEM + PRTxxMF.

4.2.2. Simple Standalone Mode

Simple Standalone Mode

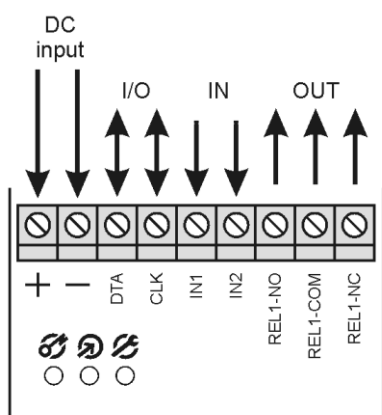

PRT reader configured for Full Standalone Mode rcdr056

The CLK and DTA lines may operate either as inputs or outputs. The function assigned to CLK or DTA line automatically defines whether this line will operate as output or input. If configured to be an output, the CLK or DTA line operates as an open collector line capable to sink up to 150 mA. Such a current is usually sufficient to drive relay used for a door lock control. When necessary, both lines (CLK and DTA) can be configured to the same output function and connected together (shorted) for increased output current (max. 300mA). IN1 and IN2 lines operate always as programmable inputs. The built-in REL1 operates as output only. Each I/O line can be configured to have one of several available functions.

Note: If output is used to control door lock then it is necessary to connect general purpose diode (e.g. 1N4007 in parallel to prevent electric tensions. The diagram for connection of the diode is shown on the last pages of this manual.

5. STANDALONE MODE

5.1. USERS

When operating in standalone mode, the PRTxxMF reader can register up to 120 users, each with a card and/or PIN (3-6 digits). Entry of a PIN code must be followed by the [#] which is required to mark the end of the PIN. Users are registered with successive numbers (ID=0-119). The reader prevents programming of the same identifier (card or PIN) more than once.

Note: In standalone mode reader uses full card code (40 bits).

The reader supports five types (classes) of users:

- MASTER
- INSTALLER
- NORMAL
- TOGGLE
- TOGGLE LTD

Types of Users			
Type	ID	Authorisation	Programming
MASTER	None	MASTER user is allowed to enter User Programming mode and can have card and/or PIN.	Memory Reset
INSTALLER	None	INSTALLER user is allowed to enter Installer Programming mode and can have card and/or PIN.	Memory Reset
NORMAL	0-119	NORMAL users are authorized to unlock the controlled door and they can have card and/or PIN.	User Programming
TOGGLE	0-119	TOGGLE users are authorized to unlock the controlled door and to switch reader between armed and disarmed modes, they can have card and/or PIN.	User Programming
TOGGLE	0-119	TOGGLE LTD (TOGGLE LIMITED) are authorized to	User

LTD		switch reader between armed and disarmed modes, they can have card and/or PIN.	Programming
Note: All users can be programmed from RARC program as well.			

Note: MASTER and INSTALLER cards can be used as **Programming Cards** to start associated programming mode and to program reader based on multiple card readings method.

5.1.1. Managing the Users

A new user can be registered in the reader using either the **Simple Programming** or **Full Programming** procedure.

The **Simple Programming** procedure consists of PIN and/or card programming without specifying the ID number of a user to whom the programmed PIN/card is assigned — as the result reader simply stores the PIN/card in the first unoccupied user's ID number. When the card is lost or PIN is forgotten then the only way to remove such user from reader's memory is to make Memory Reset and erase all users from memory.

The **Full Programming** procedure requires specifying of the ID number for the new user being programmed which has to be followed by his PIN and/or card. When this method is applied then users can be removed from memory selectively based on their Ids.

5.1.2. User Identification

In PRT series readers every user can be recognized by identifier i.e. card or PIN. If **Card and PIN** Identification mode is configured in the reader then both identifiers must be used (first card and then PIN when green LED OPEN  pulsates). Identification mode is programmed individually for primary and secondary reader. The mode concerns NORMAL, TOGGLE and TOGGLE LTD users and it does not concern MASTER and INSTALLER users as they always follow **Card or PIN** Identification mode thus starting of programming procedure requires only one of identifiers i.e. card or PIN.

5.2. DOOR UNLOCKING

The reader can grant access (unlock door) when the NORMAL or TOGGLE user is properly identified at the reader or the input with function **[22]: Exit button** is triggered. When the access is granted then LED OPEN  (green) is activated for the time of door unlocking. Door lock remains released until door closing is recognized or time specified by the timer **Door Unlock Time** elapses. Door should be closed before the time specified by the timer **Door Open Timeout** elapses (it is counted when Door Unlock Time elapses) or Door Ajar alarm is raised.

The reader denies access:

- When entered identifier (card/PIN) is not valid (unknown)
- When reader is armed and the option **Access disabled when reader armed** is active
- When TOGGLE LTD identifier is used
- When identification method is not complete (e.g. user presented only card but **Card and PIN** mode is configured)

Note: With the option **Access disabled when reader armed**, TOGGLE or TOGGLE LTD users may change reader's arming mode thus enabling or disabling access to controlled door. Therefore, armed and disarmed states can be used for additional access control.

5.3. FACILITY CODE

The **Facility Code** (also called **Site Code**) is a specific part of the entire card code which indicate group of cards. For example when **Facility Code** is defined as 245 all cards which begin with "245" will comply with given **Facility Code** (e.g. 24532AB450, 245D4523AA, 2453456231 will comply while 12A4562432, 3214534522, 2353414422 will not).

When **Facility Code** option is active reader first searches if the card belongs to any user registered in the reader, if not, it verifies if this card comply with given **Facility Code**, when yes then card is accepted as valid NORMAL user card, if not then card is rejected.

Thanks to this feature reader may be used to grant access to larger number of users which are not programmed individually into the reader but they have cards which comply with given **Facility Code**.

The whole card code may have up to 10 digits coded in HEX (13 digits coded in DEC). When defining the **Facility Code** installer must specify digit locations and their values in HEX format. For

example when **Facility Code** is defined as "xxxx1ABxxx" then every card which has the same pattern is accepted by the reader regardless of the fact that it is not registered individually in reader's memory. The positions marked with x are not analyzed for compliance with **Facility Code**.

5.4. ARMING MODES

Reader in standalone operating mode can be switched between **Armed** and **Disarmed** modes. The actual arming mode of the reader is indicated on the dual color LED STATUS , which lights in red for **Armed** and green for **Disarmed**. Optionally, the actual arming mode can be indicated on the output line configured to option **[44]: Disarmed Mode** or **[45]: Armed Mode**. Such a configuration allows the output line to be used to arm/disarm of a connected alarm system or to switch on/off some other auxiliary system or device (e.g. heating, lights etc.). In general, the current arming mode of the reader have no influence on access rights unless the option **Access disabled when reader armed** is enabled. With this option activated, reader can only grant access when it works in disarmed mode.

Using the option mentioned above the TOGGLE and TOGGLE LTD users are allowed to enable or disable access to the supervised room through switching the reader between armed and disarmed modes. Also, it allows for automatic access locking upon the reader entering **Armed** mode.

Note: Although the arming modes of the reader were originally designed for integration with alarm system, they can be alternatively used for other control purposes which require on/off control method (light control, heating control etc). Upon powering on, reader automatically returns to the arming mode it was before powering off. Also, the reader returns to its previous arming mode when leaving the programming mode. After **Memory Reset** reader always enters **Armed** mode.

5.4.1. Arming/Disarming Methods

Note: The term "arming" should be understood here as switching to **Armed** mode, whereas the term "disarming" as switching to **Disarmed** mode. The term "reader's arming mode" should be understood as actual state (either **Armed** or **Disarmed** mode) of the reader.

Reader can be armed/disarmed by means of TOGGLE/TOGGLE LTD users or by input line programmed with function **[24]: Arming/Disarming Key Switch**. When arming mode is controlled by input **[24]** reader changes its arming mode solely and unconditionally, according to the current state of this input.

Attempt to arm the reader by means of TOGGLE or TOGGLE LTD users is rejected in following situations:

- When input **[23]: Arming Disabled** is active (which might indicate that alarm system is not ready for arming)
- When input **[21]: Door Contact** is open (door is not closed)
- When input **[27]: Intruder** is open (intruder detected in area)

None of conditions listed above affects disarming of the reader – disarming is always unconditional.

Arming/Disarming by TOGGLE user card or PIN

The action needed by a TOGGLE user to change arming mode of the reader is to read twice (sequentially) the TOGGLE card or to enter twice (sequentially) the TOGGLE PIN code — however, when reader operates with the **Card and PIN** option, user needs to do both things for the first time (read a card and then subsequently enter his PIN) but with the second attempt he can use only one method (card or PIN).

Note: If access is not disabled by option **Access disabled when reader armed** then with first usage of TOGGLE user card/PIN reader automatically releases door lock and then waits for second (optional) usage of TOGGLE identifier to change current arming mode.



Arming/Disarming by TOGGLE LTD user card or PIN

TOGGLE LTD users may arm/disarm the reader simply by single use of his identifier (card, PIN or both when **Card and PIN** option is active).



Examples

Example 1: Rearming the reader by presenting a TOGGLE user card





- Read your TOGGLE user card

- Once accepted the reader grants you access (assuming that access is not disabled by option **Access disabled when reader armed**) and LED SYSTEM  starts blinking
- When LED SYSTEM  is blinking, once again present your TOGGLE card
- Reader will change its arming state and the LED STATUS  will change its color

Example 2: Rearming the reader by entering a TOGGLE user PIN code

- Key in the TOGGLE user PIN code, use [#] key to mark the end of a PIN
- Once accepted the reader grants you access and its LED SYSTEM  starts blinking
- When LED SYSTEM  is blinking, once again enroll your TOGGLE user PIN code
- Reader will change its arming state and LED STATUS  will change its color

Example 3: Rearming the reader by TOGGLE user when Card and PIN option is active

- Present your TOGGLE user card, LED OPEN  starts blinking which means that reader waits for TOGGLE PIN
- Enroll your TOGGLE user PIN
- Once accepted, reader will grant you access (assuming that access is not disabled by option **Access disabled when reader armed**) and LED SYSTEM  starts blinking
- When LED SYSTEM  is blinking, once again present your TOGGLE card or enter you TOGGLE PIN
- Reader will change arming mode and LED STATUS  will change its color

Arming/disarming by input

With input programmed to option **[24]: Arming/Disarming Key Switch** the current arming mode of the reader is solely controlled by the electrical state on this input. When line is open (not triggered) reader is forced to **Armed** mode, when closed (triggered) reader switches to **Disarmed** mode and remains in this state as long as line is active.

When reader's arming mode is controlled through input **[24]** the usage of TOGGLE and TOGGLE LTD card/PIN is modified. In this case using TOGGLE/TOGGLE LTD card/PIN changes temporary (for approx. 8 sec.) current reader's arming mode. If during this period the signal connected to input **[24]** will change its state (what would mean that controlled alarm system changed its arming mode as well) then the reader will remain in this new arming mode. In opposite, when during this limited 8 sec. period the input **[24]** will not change its state (what would mean that the alarm system did not changed its arming mode) reader will restore previous arming mode.

Note: When reader's arming mode is controlled through input **[24]** the condition of the input **[23]: Arming Disabled** (if programmed) is limited to disable the use of TOGGLE/TOGGLE LTD user card/PIN and doesn't affect process of arming and disarming.

Using reader for arming/disarming of the alarm system

There are several scenarios which can be used for integration between alarm system and the reader. Below, you will find the most complex way for integration between alarm system and the reader.

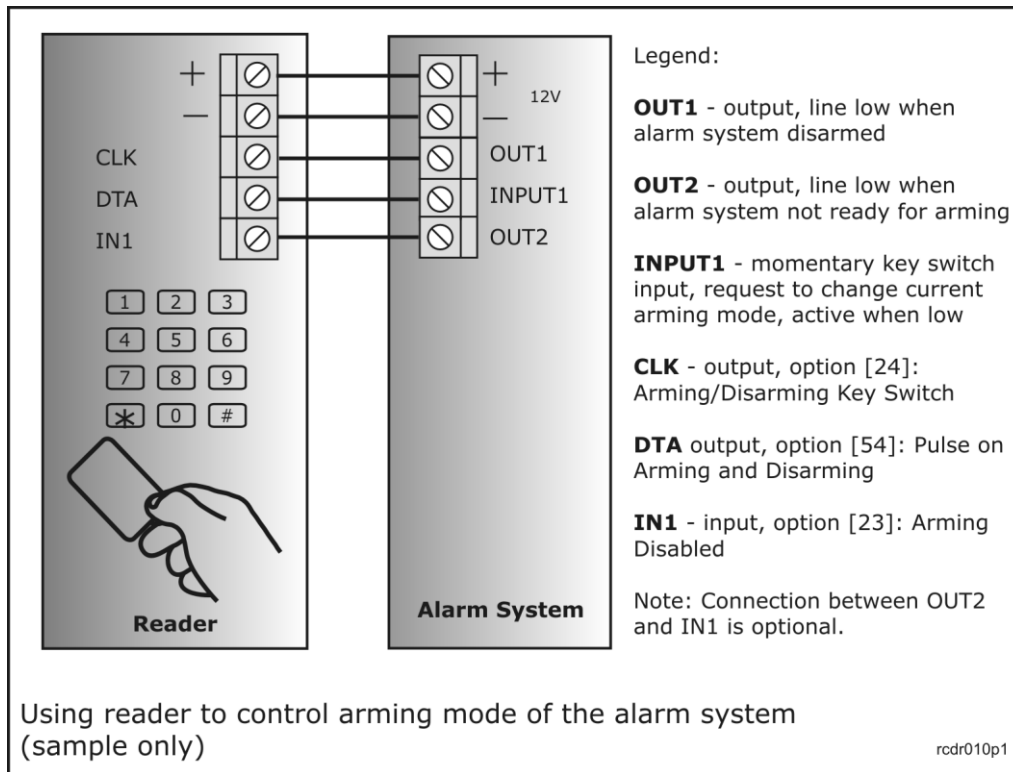

When using proposed configuration the current arming mode of the reader is controlled by the alarm system (output line from alarm system controls reader’s arming state), as a result reader always operates in the same arming mode as alarm system. Using TOGGLE or TOGGLE LTD card/PIN users can “request” the reader (and thus the alarm system as well) to change its current arming mode. Once the TOGGLE/TOGGLE LTD user changed temporary arming mode, reader waits approx. 8s for the alarm system to follow this change, if not reader restores previous arming mode however if alarm system will change its arming mode then reader will stay in this new arming mode as well. There are following benefits related with this scenario:

- Whenever alarm system changes its arming mode reader follows this change
- The actual arming mode of the alarm system is presented on the reader’s LED STATUS
- TOGGLE/ TOGGLE LTD users can change arming mode of the reader and the connected alarm system
- Alarm system can be controlled simultaneously from system keypads and from the reader (using the reader doesn’t collide with alarm system keypads)

In order to implement this scenario alarm system should provide following signal lines:

- Latched output which indicates current arming mode of the alarm system (zone)
- Momentary input which when triggered requests change of current arming mode of the alarm system (zone)
- Latched output which indicates whether the alarm system (zone) is ready for arming or not

The output line which indicates that alarm system is ready for arming is not necessary and can be omitted, however when connected to reader’s input **[23]: Arming Disabled** it will make that every attempt to arm the reader by TOGGLE/TOGGLE LTD users will be immediately rejected by the reader (reader will generate error sound and will not change its arming mode, even for temporary time).

Note: In some cases it can be essential to hide current arming state of the alarm system or reader therefore it is possible to use function which will conceal arming mode displayed by the reader (see option: **LED STATUS Masking** later in this document).

5.5. DOOR BELL FUNCTION

By default the **[F1]: Door Bell** and **[F2]: Light Bulb** keys operate as door bell buttons. When pressed they produce continuous sound generated by the internal buzzer and optionally can trigger the **[47]: Door Bell** output (if programmed). Both indications last for 5 seconds and cease automatically even when the key is still pressed. The door bell indication can be triggered either from primary or secondary reader. Also, the door bell can be triggered through the separate press of **[#]** key. This method is especially useful when F1 and F2 keys were programmed to other control function or don't exist on the particular device.

Note: When **[#]** key is pressed to conclude PIN then door bell indication is not generated. Only separate, individual press of **[#]** key triggers door bell signalling.

5.6. FUNCTION KEYS

As mentioned above, by default, in standalone mode (both **Full** or **Simple Standalone Mode**) pressing the F1 or F2 key results in door bell signalling however this rule is not valid if you program any output with one of following functions: **[48]**, **[49]**, **[50]** or **[51]**.

If you program any output with function **[48]: AUX1 Momentary** or **[50]: AUX1 Toggle** then pressing of the F1 key will no longer trigger door bell but it will trigger AUX1 output.

If you program any output with function **[49]: AUX2 Momentary** or **[51]: AUX2 Toggle** then pressing of the F2 key will no longer trigger door bell it will trigger AUX2 output.



Note: If you press function key on primary or secondary reader the system will react in the same way.

5.7. DOOR ALARM

The **Door Alarm** is a compound state which consists of one or more events which are related to controlled door:

- Forced Entry
- Prealarm
- Door Ajar

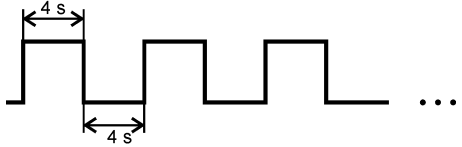
The **Door Alarm** state can be signalled with the dedicated output **[46]: Door Alarm** and optionally on the internal buzzer (option: **Door Alarm indication on internal buzzer**). For indication of each particular type of alarm reader uses different signal modulation.

Door Alarm			
Event	Priority	Output modulation method	Alarm situation
Forced Entry	High	Sequence: Active - 4 s, Pause - 4 s 	A door was opened in unauthorized method. This state can be cleared by entering any valid identifier or it disappears automatically after 3 minutes.
Prealarm	Medium	Sequence: Active - 1 s, Pause - 1 s 	Detection of five consecutive usages of unknown card/PIN made within 5 minutes. Entering valid card/PIN clears fault attempt counter. During Prealarm state reader disables reading of cards and PIN-s thus blocking the users' identification for 5 minutes.
Door Ajar	Low	Sequence: Active - 1 s, Pause - 1 s, Active - 1 s, Pause - 5 s	Door not closed within Door Open Timeout . This state can be cleared by entering

			any valid identifier or disappears automatically after 3 minutes. Also, closing door immediately clears this alarm.
Note: Modulation methods are used for both, the output line and for internal buzzer (if configured for alarm indication).			

Note: The **Forced Entry** and **Door Ajar** alarms can occur only if the reader operates with a door open sensor connected to the input with function **[21]: Door Contact**.

5.8. TAMPER ALARM

This alarm is dedicated to indicate that reader circuit is tampered and it is triggered by external detector connected to reader's input configured with the function **[26]: Tamper**. The alarm is operated independently from internal tamper switch which is activated by reader's enclosure opening or detachment from the place of installation. **Tamper Alarm** can be raised either in armed or disarmed mode. Once this alarm emerges reader starts counting **Tamper Timer** and activates outputs with functions **[55]: Tamper Alarm** and/or **[57]: General Alarm** (if programmed). When **Tamper Timer** is counted down then reader disables **[26]: Tamper** input thus protecting the reader from multiple tamper alarms. The **Tamper Alarm** ceases automatically when **Tamper Timer** elapses or reader changes its arming mode.

5.9. INTRUDER ALARM

This alarm is dedicated to indicate that intruder is penetrating area protected with sensor connected to reader's input **[27]: Intruder** or door was opened in unauthorized method (**Forced Entry**). The **Intruder Alarm** can be raised in armed mode only. Once this alarm emerges reader starts counting **Intruder Timer** and activates outputs with functions **[56]: Intruder Alarm** and/or **[57]: General Alarm** (if programmed). When **Intruder Timer** is counted down then reader disables **[27]: Intruder** input thus protecting the reader from multiple intruder alarms. This alarm ceases automatically when **Intruder Timer** elapses or reader changes its arming mode.

5.10. DURESS ALARM

Reader can be configured to recognize and signal entering of the PIN code under duress. When option **Duress Alarm** is enabled reader will treat PIN code as under duress when the last digit of the entered PIN code differs by +/- 1 from the original one. The **Duress Alarm** can be indicated on the output with function **[60]: Duress Alarm** while the signalling time can be adjusted by **Duress Alarm Timer**. This alarm ceases automatically when **Duress Timer** elapses or reader changes its arming mode.

5.11. GENERAL ALARM

This alarm is a sum of two separate alarms: **Tamper Alarm** and **Intruder Alarm** and it is triggered whenever one of them is raised. **General Alarm** can be indicated on the output line with function **[57]: General Alarm** while the signalling time can be adjusted by **General Alarm Timer**. This alarm ceases automatically when **General Alarm Timer** elapses or reader changes its arming mode.

5.12. EVENTS RECORDING

Reader is capable to record several types of events with their time stamps. Events are stored in cyclic (FIFO) buffer – when entire event memory is occupied reader removes oldest events to releases space for the new ones to come. The reader can record up to 1000 events.

List of events		
Code	Event Name	Description
100	Access granted	Access for the user (ID + name) has been granted
101	Access granted - Facility Code	Access has been granted for card with valid Facility Code

102	Access denied	Access for the user (ID + name) has been denied
103	Access denied - Facility Code	Access has been denied for card with valid Facility Code
200	Reader armed	Reader has been switched to Armed mode by user (ID + name)
201	Reader disarmed	Reader has been switched to Disarmed mode by user (ID + name)
104	Door unlocked	Door lock has been unlocked
105	Door relocked	Door lock has been re-locked
106	Door open	Door has been opened
107	Door closed	Door has been closed
108	Exit button	Input [22]: Exit Button has been triggered
202	Arming disabled	Arming has been disabled through input line [23]: Arming Disabled
203	Arming enabled	Arming has been re-enabled through input line [23]: Arming Disabled
204	Arming by input	Reader has been armed by input line [24]: Arming/Disarming Key Switch
205	Disarming by input	Reader has been disarmed by input line [24]: Arming/Disarming Key Switch
006	Summer time	Clock has been pushed backward by 1 hour
007	Winter time	Clock has been pushed forward by 1 hour
109	Door bell	Door bell indication triggered
300	Forced entry	Door opened in unauthorized way
304	Door ajar	Door open to long
301	Prealarm	Five consecutive attempts to enter wrong PIN or card within 5 minutes - Prealarm signaling started
112	Unknown card	The unknown card has been entered (card code)
113	Unknown PIN	The unknown PIN has been entered (PIN code)
003	User Programming	Reader switched to User Programming mode
004	Installer Programming	Reader switched to Installer Programming mode
005	Online mode	Reader switched to online communication mode with PC
000	Reader restarted	Reader passed through initialization procedure (the same as during power on)
001	Clock cleared	The internal clock of the reader has been cleared
002	Clock changed	The internal clock of the reader has been programmed
302	Tamper Alarm	Reader entered Tamper Alarm state
303	Intruder Alarm	Reader entered Intruder Alarm state

305	Duress Alarm	Reader entered Duress Alarm state
999	Unknown event	Event code doesn't fit any known event – error in data

5.13. REAL TIME CLOCK

The reader is equipped with Real Time Clock (RTC) predefined for 100 year. This clock is used to append a time stamp to every event recorded by the reader. The RTC clock has not battery back-up so it resets to 2000-01-01 00:00 whenever power is off. When required, the RTC can be configured to switch automatically to winter or summer time.

Note: When reader's Real Time Clock is unset (or lost due to lack of power supply) reader continues its operation however this can be changed. When option **Real Time Clock Control** is enabled then the reader will stop its operation till the clock is programmed again (see Installer Programming, function [78]).





5.14. TIMERS

Reader uses several timers, each timer is assigned to specific function and can be programmed in seconds or minutes.

ID	Timer	Default	Function
0	Door Unlock Time (00-99 sec./min.)	4 s	Defines time for which door lock will be released. This timer controls following outputs: [41]: Door Lock , [42]: Door Lock Exit , [43]: Door Lock Entry .
1	Door Open Timeout (00-99 sec./min.)	12 s	Determines time in which door should be closed. Door Open Timer starts from the moment when Door Lock Time has passed out.
2	AUX1 (00-99 sec./min.)	2 s	Defines duration time for output [50]: AUX1 Momentary . Programming timer to 00s makes that timer counts down for unlimited period till moment when reader changes it arming mode.
3	AUX2 (00-99 sec./min.)	2 s	Defines duration time for output [51]: AUX2 Momentary . Programming timer to 00s makes that timer counts down for unlimited period till moment when reader changes it arming mode.
4	Pulse on Arming (01-99 sec./min.)	2 s	Defines duration time for output [52]: Pulse on Arming .
5	Pulse on Disarming (01-99 sec./min.)	2 s	Defines duration time for output [53]: Pulse on Disarming .
6	Pulse on Arming/disarming (01-99 sec./min.)	2 s	Defines duration time for output [54]: Pulse on Arming/disarming output.
7	Tamper Alarm (00-99 sec./min.)	60 min	Defines duration time for Tamper Alarm . Programming timer to 00s makes that timer counts down for unlimited period till moment when reader changes it arming mode.
8	Intruder Alarm (00-99 sec./min.)	60 min	Defines duration time for Intruder Alarm . Programming timer to 00s makes that timer counts down for unlimited period till moment when reader changes it arming mode.
9	General Alarm	3 min	Defines duration time for General Alarm . Programming timer to 00s makes that timer

	(00-99 sec./min.)		counts down for unlimited period till moment when reader changes it arming mode.
10	Duress Alarm (00-99 sec./min.)	3 min	Defines duration time for Duress Alarm . Programming timer to 00s makes that timer counts down for unlimited period till moment when reader changes it arming mode.
11	LED STATUS Masking (01-99 sec./min.)	20 s	Defines duration time for LED STATUS before it will switch to neutral mode when it lights up in red and green alternatively.

5.15. OPTICAL AND ACOUSTIC SIGNALS

LED Signals			
LED STATUS	LED OPEN	LED SYSTEM	Description
			
Green	—	—	Reader is disarmed.
Red	—	—	Reader is armed.
Red	ON	—	Reader is in User Programming mode.
Green	ON	—	Reader is in Installer Programming mode.
—	—	Flashing	During programming: reader is waiting for the user to enter the next part of the command or programming function.
		Flashing	During normal operation: reader is waiting for a TOGGLE user to enter his identifier once again in order to change reader's arming mode.
—	—	Single flash	A user identifier (Card or PIN) has been entered.
—	ON	—	The door lock is activated, this LED remains on as long as a door is unlocked.
—	Flashing	—	Reader is waiting for the PIN (when Card and PIN mode is valid).
	ON		Door is being unlocked (lock released).
—	—	ON	When LED SYSTEM  is lit and accompanied with short beep periodically repeated it means that either configuration memory is corrupted or MASTER and INSTALLER identifiers are not programmed yet. In this case reader must be totally reprogrammed. When LED SYSTEM  is lit and no sound is generated it means that error in firmware was detected. To fix this problem the proper firmware must be uploaded into the reader.

Acoustic Signals		
Signal	Symbol	Description
One long signal	-	Error - unknown identifier, access denied.
Three short beeps	* * *	Command successfully completed (OK signal).
Two short beeps	* *	Prompt signal, the reader is waiting for the next part of the command to be entered. This signal is intended to encourage the programmer to proceed with next programming steps.
Long beep continuously repeated	- - - - - ...	Reader has detected problem (either configuration memory is corrupted and reader must be reconfigured anew). This signal is accompanied by the steady lit LED SYSTEM  .
Legend: - long beep, * beep		

5.16. OPERATION WITH XM-2 I/O EXPANDER

In **Full Standalone Mode**, reader can be connected with XM-2 I/O expander. Each input and output of the XM-2 can be programmed in the same way as internal inputs and outputs of the reader. The XM-2 should be connected to the reader's CLK and DTA lines and must have address set to ID=5. The maximum distance between the reader and XM-2 expander is limited to 150 m.

Note: The XM-2 expander has two red LED-s which are intended to indicate triggering of corresponding relay output (REL1 or REL2) and one green LED which lights continuously when communication with host reader is working and blinking when broken.

5.17. OPERATION WITH SECOND PRT SERIES READER

In **Full Standalone Mode**, the main PRTxxEM reader can operate with second PRT series reader, even if it works with another card standard (e.g. Mifare). The access system with two readers using different card technologies can be used for installations with two card technologies. The second PRT reader should be connected with main (primary) reader and configured with **RACS address ID=0** operating mode. The pair of two readers can be used for read-in/out door control or for manual programming when the main reader is not equipped with keypad. The maximum distance between primary and secondary PRT reader is limited to 150 m.

Note: The LED-s and buzzer on secondary reader copy (imitate) the LED-s/buzzer of primary reader.

6 . P R O G R A M M I N G

The reader can be programmed:

- From the PC with RARC program (RS232)
- From the keypad located on the main reader
- From the keypad located on the external (secondary) reader
- Through multiple reading of the so called **Programming Card**

Preparing the Reader for Terminal Mode (Online mode)

If the unit is dedicated for **Terminal Mode** (slave operation), then it is only necessary to program [000]..[003] operating mode. It can be done either manually during **Memory Reset** or remotely from PC.

Preparing the Reader for Standalone Mode (Offline mode)

If the unit is dedicated for **Standalone Mode** (autonomic operation) then proceed with programming procedure:

1. Configure the reader to either **Full** or **Simple Standalone Mode** operating mode and program MASTER and INSTALLER cards and/or PIN-s (**Memory Reset**)
2. Configure the reader for specific installation scenario (**Installer Programming**)
3. Program cards and PIN-s for users (**User Programming**)

Alternatively all three steps can be programmed entirely from the RARC program when reader is connected to PC.

6.1. PROGRAMMING OF READERS WITHOUT KEYPAD

6.1.1. Programming Through Multiple Readings of the Programming Card

Although some readers are not equipped with keypad they can still be programmed manually with the same programming procedures as readers with keypads. The difference in programming is such that instead of pressing certain keys (like you normally do when programming readers with keypad) you must emulate key pressing by multiple readings of **Programming Card**. For example in order to emulate key [9] you must read **Programming Card** 9-times (simply present it to the reader and take it back 9 times) and then wait approx. 3 seconds for the reader to generate a confirmation signal (two beeps) which means that series of card readings is accepted as an equivalent of key pressing and the reader is now waiting for the next step of the programming procedure.

Use following cards as **Programming Cards**:

- In the **Installer Programming** use INSTALLER card
- in the **User Programming** use MASTER card
- in the **Memory Reset** procedure use any EM125kHz proximity card

Key	Emulation Method
[1]..[9]	Read card [N]-times where [N] is equal to programmed digit
[0]	Read Programming Card 10-times
[*]	Read Programming Card 11-times
[#]	Read Programming Card 12-times
Note: Each time you complete the sequence of multiple readings of the programming card wait for the reader to generate signal (two beeps) which will confirm that reader has accepted series of card readings as the equivalent of key pressing.	

Example: In order to enter following programming sequence [][1][0][ID][#] where ID=113 do following:*

1. [*]: Read 11-times programming card and then wait for two beeps
2. [1]: Read 1-time programming card and then wait for two beeps
3. [0]: Read 10-times programming card and then wait for two beeps
4. [1]: Read 1-time programming card and then wait for two beeps
5. [1]: Read 1-time programming card and then wait for two beeps
6. [3]: Read 3-times programming card and then wait for two beeps
7. [#]: Read 12-times programming card and then wait for two beeps

Note: Reader which is not equipped with keypad can be configured with **Programming card** or from another external reader with keypad but the recommended method is to use RARC software.

6.1.2. Programming From The External Reader

In this case, the primary reader should be configured for **[031]: Offline Mode, Full Standalone** while secondary reader must be configured for **[000]: Online mode, RACS address ID=0** and connected via CLK and DTA lines to primary reader (for details see wiring diagram for **Full Standalone Mode**). Once two readers are connected all programming procedures are made on



keypad located on secondary (slave) reader. The LED/buzzer signals occur simultaneously on both readers (primary and secondary). Both readers must have the same supply minus. It is not required to disconnect the XM-2 expander from system being currently programmed.

6.2. MEMORY RESET

The **Memory Reset** is a procedure which erases reader's memory (all cards, all PIN-s including MASTER and INSTALLER users) and restores factory default settings. It also enables programming of operating mode and MASTER as well as INSTALLER identifiers (if required). Additionally it enables configuration of IN1 and IN2 inputs in Wiegand and Magstripe Terminal modes.







Note: Memory Reset procedure has several variants depending on selected operating mode in step 7. Steps 1-6 are the same for all variants.

Memory Reset procedure(variant 1 for standalone/offline operation):

1. Power down the unit (or place jumper on RST contacts).
2. Remove all connections from CLK, IN1 and RTS lines.
3. Make electrical bridge between CLK and IN1.
4. Restore power (or remove jumper from RST contacts).
5. While LED OPEN  (green) is flashing and is accompanied with continuous sound disconnect CLK from IN1.
6. Wait till LED SYSTEM  starts flashing.
7. Enter three digits which will configure the reader for required operating mode i.e. [030] or [031]. Reader generates two beeps with every entered digit.
8. Enter new MASTER PIN code (3-6 digits) followed by [#] key or skip this step and go to the next one.
9. Present any card to the reader — this card will become a new MASTER card or skip this step by pressing [#] and go to the next one.
10. Enter a new INSTALLER PIN code (3-6 digits) followed by [#] key or skip this step and go to the next one.
11. Present another (second) card to the reader — this card will become a new INSTALLER card, or skip this step by pressing [#] and go to the next one.
12. Once the previous step is completed reader automatically ends the **Memory Reset** and switches to normal operation.

Note: If you configure the reader for standalone operation mode but you don't program MASTER PIN/card you will not be able to enter User Programming. Also, if you configure the reader for standalone operation mode but you don't program INSTALLER PIN/card you will not be able to enter Installer Programming.



Memory Reset procedure(variant 2 for Wiegand and Magstripe formats):

1. Power down the unit (or place jumper on RST contacts).
2. Remove all connections from CLK, IN1 and RTS lines.
3. Make electrical bridge between CLK and IN1.
4. Restore power (or remove jumper from RST contacts).
5. While LED OPEN  (green) is flashing and is accompanied with continuous sound disconnect CLK from IN1.
6. Wait till LED SYSTEM  starts flashing.
7. Enter three digits which will configure the reader for required operating mode i.e. [020], [021] or [1xx]. Reader generates two beeps with every entered digit.
8. When LED SYSTEM  is on, enter two digits to define the function of IN1 input:
 - [11]: Line off
 - [25]: LED STATUS  control
 - [28]: Buzzer control
 - [29]: LED OPEN  control
 - [30]: LED SYSTEM  control.
9. Enter two digits to define the function of IN2 input in the same way as in case of IN1.

- Once the previous step is completed reader automatically ends the **Memory Reset** and switches to normal operation.

Note: If in the step 6 no function is selected within 9 s or both steps are skipped with # key then Memory Reset is completed with default settings i.e. IN1=[29] and IN2=[28]. It is forbidden to assign the same functions to both inputs except for the function [11].

Memory Reset procedure(variant 3 for RACS and RS232 formats):

- Power down the unit (or place jumper on RST contacts).
- Remove all connections from CLK, IN1 and RTS lines.
- Make electrical bridge between CLK and IN1.
- Restore power (or remove jumper from RST contacts).
- While LED OPEN  (green) is flashing and is accompanied with continuous sound disconnect CLK from IN1.
- Wait till LED SYSTEM  starts flashing.
- Enter three digits which will configure the reader for required operating mode i.e. [000].. [003], [01x] or [040]. Reader generates two beeps with every entered digit.
- Once the previous step is completed reader automatically ends the **Memory Reset** and switches to normal operation.

Note: When in step 7 an unknown operating mode is entered or no operating mode is entered for 20 s then reader will automatically exit the Memory Reset procedure.

7 . O P E R A T I N G M O D E S

The factory new reader is pre-configured with **[030]: Offline mode, Simple Standalone**. In order to change operating mode reader should be connected to PC (RARC software) or reprogrammed manually (**Memory Reset**).

Operating modes		
Code	Operating mode	Description
000	Online mode, RACS address ID=0	Reader operates as a slave unit connected to the Roger access controller.
001	Online mode, RACS address ID=1	
002	Online mode, RACS address ID=2	
003	Online mode, RACS address ID=3	
010	Online mode, RS232, PINs transmitted as separate digits	Reader is connected to the host through RS232 (9600,N,8,1) serial interface. Each key pressed is transmitted separately as HEX BCD digit. Key coding as below: Card output format: STX (02h) / Data (10 x hex digits coded ASCII) / CR (0Dh) / LF (0Ah) / ETX (03h) Key output format: STX (02h) / Data (2 x hex digits coded ASCII) / CR (0Dh) / LF (0Ah) / ETX (03h)

011	Online mode, RS232, PINs transmitted as whole numbers	<p>Reader is connected to the host through RS232 (9600,N,8,1) serial interface. Each key entry is buffered, once the [#] key is pressed reader transmits entire PIN code as a single number max 16 digits long. The [#] key is treated as the end of PIN entry and not transmitted. Special keys [*], [F1] and [F2] are transmitted in the same way as entire PINs.</p> <p>Card output format: STX (02h) / Data (10 x hex digits coded ASCII) / CR (0Dh) / LF (0Ah) / ETX (03h)</p> <p>PIN output format: STX (02h) / Data (up to 16 hex digits coded ASCII) / '#' / CR (0Dh) / LF (0Ah) / ETX (03h)</p> <p>Special keys: [*]: STX / 'A' / '#' / CR / LF / ETX [F1]: STX / 'C' / '#' / CR / LF / ETX [F2]: STX / 'D' / '#' / CR / LF / ETX</p>
020	Online mode, Magstripe (only card)	Reader operates as a slave unit connected to the host controller which requires Magstripe data transmission format, keys are not transmitted.
021	Online mode, Magstripe (card or PIN)	Reader operates as a slave unit connected to a host controller which requires Magstripe data transmission, keys transmitted as single digits, format is compatible with specification of UNITEK controllers (with transmission of PIN-s).
030	Offline mode, Simple Standalone	Reader operates in standalone mode, the CLK and DTA lines serve as ordinary I/O lines.
031	Offline mode, Full Standalone	Reader operates in standalone mode, the CLK and DTA lines are used for communication with remote XM-2 I/O and second (optional) PRT reader.
040	Online mode, RS232 EPSO protocol	Reader is connected to the host through RS232 serial interface. The host exchanges data with the reader using EPSO2 protocol .
10x	Online mode, 26 bit Wiegand	Reader operates as a slave unit connected to the host controller that requires specific Wiegand data transmission format.
11x	Online mode, 34 bit Wiegand	
12x	Online mode, 42 bit Wiegand	
13x	Online mode, 66 bit Wiegand	
14x	Online mode, 32 bit Wiegand, without priority	
15x	Online mode, 32 bit Wiegand, without parity, reverse order	
<p>Note: For Wiegand data formats the third digit of the operating mode code (marked by "x") specifies the method which reader uses when transmitting PIN-s or keys. For details regarding methods of PIN transmission refer to table below.</p>		



PIN/keys transmission options		
X	Description	Details
X=0	1-10 digits long PIN, transmitted in BCD format	Each key pressed is buffered in reader's memory; with a press of a [#] key reader transmits entire PIN code. The PIN code is transmitted as a BCD coded number.
X=1	1-12 digits PIN, transmitted in binary format	Each key pressed is buffered in reader's memory; with a press of a [#] key reader transmits entire PIN code. The PIN code is transmitted as a binary number.
X=2	Each key pressed is transmitted separately as 4-bit number plus 2 control bits	Each key pressed is immediately transmitted to the host controller as a sequence of 6 bits (EXXXXP) where XXXX represents the code of the pressed key supplemented by two control bits (E and P). The E represents the even bit calculated from the first half of a transmitted code where P represents the parity of a second half of the bit stream. This format is compatible with HID 5355 series readers, option "with parity". Key coding as in Table B (below).
X=3	Each key pressed is transmitted separately as 4-bit number	Each key pressed is immediately transmitted to the host controller as a sequence of 4 bits (XXXX) which represent the code of the pressed key, no control bits added. This format is compatible with HID 5355 series readers, option "without parity". Key coding as in Table B (below).
X=4	Each key pressed is transmitted separately as 8-bit number with parity	Each key pressed is immediately transmitted to the host controller as a sequence of 10 bits (EXXXXXXXXXP) where XXXXXXXX represents the code of the pressed key supplemented by two control bits (E and P). The E represents the even bit calculated from the first half of a transmitted code where P represents the parity of a second half of the bit stream. Key coding as in Table A (below).
X=5	Each key pressed is transmitted separately as a 8-bit number without parity bits	Each key pressed is immediately transmitted to the host controller as a sequence of 8 bits (XXXXXXXX) where XXXXXXXX represents the code of the pressed key supplemented by two control bits (E and P). The E represents the even bit calculated from the first half of a transmitted code where P represents the parity of a second half of the bit stream. Key coding as in Table A (below).
X=6	1-6 keys long PIN transmitted as Wiegand 26 bit stream with control bits	1-6 keys long PIN, each key represented by 4-bit long codes (key codes according to table B). Reader sends data after six keys are pressed or earlier when # key is pressed. Reader wait max ca. 15 seconds for each key press. Key's buffer is cleared if no keys have not been entered within ca. 15 seconds. Examples: Keys entered "1234#" - code transmitted "001234" Keys entered "123456" - code transmitted "123456"
X=7	1-4 keys long PIN transmitted as Wiegand 32 bit stream without control bits	1-4 keys long PIN, each key represented by 8-bit long codes (key codes according to table A). Reader sends data after four keys are pressed or earlier when # key is pressed. Reader wait max ca. 15 seconds for each key press. Key's buffer is cleared if no keys have not been entered within ca. 15 seconds. Examples: Keys entered "123#" - code transmitted "0123" Keys entered "123456" - code transmitted "123456"

Table A: 8-bit key coding		
Key	HEX	BIN
0	F0	11110000
1	E1	11100001
2	D2	11010010
3	C3	11000011
4	B4	10110100
5	A5	10100101
6	96	10010110
7	87	10000111
8	78	01111000
9	69	01101001
*	5A	01011010
#	4B	01001011
F1	3C	00111100
F2	2D	00101101

Table B: 4-bit key coding		
Key	ASCI	BIN
0	0	0000
1	1	0001
2	2	0010
3	3	0011
4	4	0100
5	5	0101
6	6	0110
7	7	0111
8	8	1000
9	9	1001
*	A	1010
#	B	1011

8 . I N S T A L L E R P R O G R A M M I N G

Use this mode to configure various functionalities of the reader. Alternatively all Installer Programming settings can be entered with RARC software after connection of reader to computer.

You can enter this mode by using INSTALLER card or entering INSTALLER PIN. Once in this mode the LED OPEN  (green) turns on and LED STATUS  lights in green.

8.1. PROGRAMMING COMMANDS

[53][EF] – Programming Function for CLK/REL1, EF=11, 21..27, 41..64, default: EF=41

This EF digits define the function for CLK line (when reader is configured for **Simple Standalone Mode**) or for REL1 output on XM-2 expander (when reader is configured for **Full Standalone Mode**). The CLK line can operate as input or output while REL1 always works as output. For I/O function codes see section **Input/Output Functions**.

Note: It is forbidden to program two or more inputs to the same function. This restriction is not valid for outputs. Reader indicates error when attempting to program two inputs to the same function.

[54][EF] – Programming function for DTA/REL2, EF=11, 21..27, 41..64, default: EF=44

This command sets the function for DTA line (when reader is configured for **Simple Standalone Mode**) or for REL2 output on XM-2 expander (when reader is configured for **Full Standalone Mode**). The DTA line can operate as input or output while REL2 always works as output.

[55][GH] – Programming function for IN1, GH=11, 21..27, default: GH=21

This command sets the function for IN1 input line located on the reader.

[56][GH] – Programming function for IN2, GH=11, 21..27, default: GH=11

This command sets the function for IN2 input line located on the reader.

[57][GH] – Programming function for IN1 on XM-2 expander, GH=11, 21..27, default: GH=22

This command sets the function for IN1 input located on the remote XM-2 expander.

[58][GH] – Programming function for IN2 on XM-2 expander, GH=11, 21..27, default GH=23

This command sets the function for IN2 input located on the remote XM-2 expander.

[59][J] – Programming Identification Mode for primary reader, J=0..1, default: J=0

This command sets the **Identification Mode** for the primary reader. Program J=0 for **Card or PIN** mode or J=1 for **Card and PIN** mode.

[60][J] – Programming Identification Mode for secondary reader, J=0..1, default: J=0

This command sets the **Identification Mode** for the secondary (external) reader. Program J=0 for **Card or PIN** mode or J=1 for **Card and PIN** mode.

[61][J] – Programming option “Door Alarm indication on internal buzzer”, J=0..1, default: J=0

When J=0 reader will not signal **Door Alarm** on internal buzzer, when J=1 **Door Alarm** will be signaled on output (if programmed) and buzzer as well.

[62][J] – Programming option “Access disabled when reader armed”, J=0..1, default: J=0

When J=0 reader will grant access both if it is in armed or disarmed mode, for J=1 access can be granted only in disarmed mode.

[63][S][KL] – Programming AUX1 Timer, S=0..1, KL=00..99, default: S=0, KL=02

The **AUX1 Timer** defines triggering time for **AUX1 Momentary** output. When S=0 and KL=00 then output will be triggered indefinitely until the reader's arming mode is switched. Program S=0 for seconds or S=1 for minutes. Setting S=1 and KL=00 is forbidden.

[64][S][KL] – Programming AUX2 Timer, S=0..1, KL=00..99, default: S=0, KL=02

The **AUX2 Timer** defines triggering time for **AUX2 Momentary** output. When S=0 and KL=00 then output will be triggered indefinitely until the reader's arming mode is switched. Program S=0 for seconds or S=1 for minutes. Setting S=1 and KL=00 is forbidden.

[65][J] – Programming option "Enable Card/PIN reading when Prealarm", J=0..1, default: J=0

When J=0 then the option is disabled and reader will not read cards nor PIN-s when it is in **Prealarm** state, when J=1 reader will allow to use cards/PIN-s during **Prealarm** state.

[66][J] – Programming option "Unlimited duration of Door Ajar alarm", J=0..1, default: J=0

When J=0 then **Door Ajar** alarm will be automatically cleared after 3 minutes or immediately with valid card/PIN entered. When J=1 then **Door Ajar** will last as long as door is opened.

[67][EF] – Programming function for built-in REL1 output, EF=11, 41..64, default: EF=46

This command sets the function for built-in REL1 output. The list of functions is give in section 8.1.

[68][S][KL] – Programming Tamper Timer, S=0..1, KL=00..99, default: S=1 KL=60

This timer defines duration time for **Tamper Alarm** which can be signalled with [55] function output. When S=0 and KL=00 then the alarm will be triggered indefinitely until the reader's arming mode is switched. Program S=0 for seconds or S=1 for minutes. Setting S=1 and KL=00 is forbidden.

[69][S][KL] – Programming Intruder Timer, S=0..1, KL=00..99, default: S=1 KL=60

This timer defines duration time for **Intruder Alarm** which can be signalled with [56] function output. When S=0 and KL=00 then the alarm will be triggered indefinitely until the reader's arming mode is switched. Program S=0 for seconds or S=1 for minutes. Setting S=1 and KL=00 is forbidden.

[70][S][KL] – Programming General Alarm Timer, S=0..1, KL=00..99, default: S=1 KL=03

This timer defines duration time for **General Alarm** which can be signalled with [57] function output. When S=0 and KL=00 then the alarm will be triggered indefinitely until the reader's arming mode is switched. Program S=0 for seconds or S=1 for minutes. Setting S=1 and KL=00 is forbidden.

[71][S][KL] – Programming Door Unlock Time, S=0..1, KL=00..99, default: S=0 KL= 04

The KL digits define time (in seconds when S=0 or in minutes when S=1) for which the reader will unlock a door when access is granted. When S=0 and KL=00 reader unlocks a door for unlimited time. If reader operates with door open sensor (input [21]: **Door Contact**) door is automatically re-locked when door sensor indicates corresponding door is closed again regardless of fact the **Door Unlock Time** did not pass by. Setting S=1 and KL=00 is forbidden.

[72][S][KL] – Programming Door Open Timeout, S=0..1, KL=00..99, default: S=0 KL=12

The KL digits define time (in seconds when S=0 or in minutes when S=1) for which door should be closed otherwise **Door Ajar** alarm will be raised. The **Door Open Timeout** starts immediately after **Door Unlock Time** is passed by. If the reader operates without door contact sensor then **Door Open Timeout** is ignored and has no effect on reader's operation. Setting S=1 and KL=00 is forbidden.

Note: Setting S=0 and KL=00 will set unlimited open time thus will disable indication of a **Door Ajar** alarm.

[73][S][KL] – Programming Duress Timer, S=0..1, KL=00..99, default: S=1 KL=03

This timer defines duration time for **Duress Alarm**. When S=0 and KL=00 then the alarm will be triggered indefinitely until the reader's arming mode is switched.. Program S=0 for seconds or S=1 for minutes. Setting S=1 and KL=00 is forbidden.

[74][S][KL] – Programming LED STATUS Timer, S=0..1, KL=00..99, default: S=0 KL=00

This timer defines time for which LED STATUS will be on after arming mode is changed. Program S=0 for seconds or S=1 for minutes. Setting S=0 and KL=00 or S=1 and KL=00 is forbidden.

Note: This timer has been used only when LED STATUS Masking function is activated.

[75][L] – Programming keypad backlight level, L=0..5, default: L=3

The L digit defines keypad backlight level. Program: L=0 for 0% (backlight is off), L=1 for 20%, L=2 for 40%, L=3 for 60%, L=4 for 80% or L=5 for 100% (maximum backlight).

[76][L] – Programming buzzer loudness level, L=0..5, default: L=3

The L digit defines buzzer loudness level. Program: L=0 for 0% (sound is off), L=1 for 20%, L=2 for 40%, L=3 for 60%, L=4 for 80% or L=5 for 100% (maximum sound).

[77][L] – Programming LED STATUS Masking function, L=0..1, default: L=0

When L=0 LED STATUS continuously indicates current arming mode of the unit. When L=1 LED STATUS is normally in neutral mode (sequentially switches from green to red and vice versa however whenever arming mode is changed or unit is restarted it lights up for time defined by LED STATUS timer and then switches to neutral mode again.

Note: Use this function in case you want to keep secret current arming mode of the unit.

[78][L] – Programming Real Time Clock Control option, L=0..1, default: L=0

When L=0 reader continues normal operation even when reader's clock is unset or lost. When L=1 reader stops its normal operation however user can use keypad to set clock and restore normal reader operation.

Note: When option is active and clock is unset or lost, all LED-s are pulsing and reader stops its normal operation. In order to restore normal operation set the clock either manually or from PC.

[79][D] – Programming Duress function, D=0..1, default: D=0

When D=0 reader will not either recognize nor signal entering of PIN under duress. When D=1 entering a valid PIN code with last digit modified by +/-1 will be treated as under duress and will cause signalling on output line (when programmed).

[80] [SSWW] – Programming Winter/Summer time change

SS: Day in March when time is changed from Winter to Summer (clock is moved from 2:00 to 3:00). Setting SS=00 deactivates automatic time change while programming SS=99 makes device will change Winter/Summer time on last Sunday of March.

WW: Day in October when time is changed from Summer to Winter (clock is moved from 3:00 to 2:00). Setting WW=00 deactivates automatic time change while programming WW=99 makes device will change time on last Sunday of October.

[81][PIN][#][Card] – Programming new MASTER user

Programs PIN and card for MASTER user. Optionally, program [81][PIN][#][#] to omit card programming or [81][Card] to omit PIN programming.

[82][PIN][#][Card] – Programming new INSTALLER PIN and/or card

Programs PIN and card for Installer user. Optionally, program [82][PIN][#][#] to omit card programming or [82][Card] to omit PIN programming.

[83][S][KL] – Programming “Pulse on Arming” timer, S=0..1, KL=01..99, default: S=0 KL=02

This timer defines duration time for pulse generated on [52] function output. Program S=0 for seconds or S=1 for minutes.

[84][S][KL] – Programming “Pulse on Disarming” timer, S=0..1, KL=01..99, default: S=0 KL=02

This timer defines duration time for pulse generated on [53] function output. Program S=0 for seconds or S=1 for minutes.

[85][S][KL] – Programming “Pulse on Arming/Disarming” timer, S=0..1, KL=01..99, default: S=0 KL=02



This timer defines duration time for pulse generated on [54] function output. Program S=0 for seconds or S=1 for minutes.

[#] - Exit from Installer Programming mode

Reader leaves **Installer Programming** mode and returns to normal operation (either Armed or Disarmed) depending on the state it was before.

Note: If you don't press any key for 1 min then reader will automatically leave the **Installer Programming** mode.

8.2. INPUT/OUTPUT FUNCTIONS



Input/output Functions		
Code	Name	Description
11	Line Off	Line is disabled and reader ignores electrical states on this line.
21	Door Contact	Input, when shorted with supply minus indicates that controlled door is closed.
22	Exit Button	Input, shorting this line with supply minus triggers [41]: Door Lock and [42]: Exit Door Lock outputs (when programmed) for time specified by Door Unlock Time . This input doesn't activate [43]: Entry Door Lock .
23	Arming Disabled	Input, as long as line is shorted with supply minus reader disables TOGGLE and TOGGLE LTD user from switching the reader into Armed mode.
24	Arming/Disarming Key Switch	Input, when line is shorted to supply minus reader switches <u>unconditionally</u> to Disarmed mode, when line is open reader returns and stay in Armed mode.
25	LED STATUS	Input, when programmed it controls LED STATUS  and this LED no longer presents current arming mode of the reader. When line is shorted to supply minus LED STATUS  lights in green, when open lights in red.
26	Tamper	Input, normally closed, opening this input (no matter in Armed mode or in Disarmed mode) will start Tamper Alarm and General Alarm .
27	Intruder	Input, normally closed to supply minus, opening this input during Armed mode will start Intruder Alarm and General Alarm .

28	Buzzer Control	Input, when shorted with supply minus activates buzzer.
29	LED OPEN Control	Input, when shorted with supply minus activates LED OPEN.
41	Door Lock	Output, whenever access is granted (no matter from primary or secondary or through exit button), this output is triggered for time specified by Door Unlock Time .
42	Exit Door Lock	Output, triggered whenever access is granted from primary (main) reader or by triggering of the [22]: Exit Button input, once triggered it goes on for time specified by Door Unlock Time . It is not activated when access is granted from secondary reader. This output is dedicated for rotary gates when two opening outputs (for clockwise and anticlockwise movement) are necessary
43	Entry Door Lock	Output, triggered whenever access is granted from secondary (external) reader, this output goes on for time specified by Door Unlock Time . It is not activated when access is granted from primary reader or from exit button input. This output is dedicated for rotary gates when two opening outputs (for clockwise and anticlockwise movement) are necessary.
44	Disarmed Mode	Output, line remains active as long as reader is disarmed.
45	Armed Mode	Output, line remains active as long as reader is armed.
46	Door Alarm	Output, line is used to indicate Door Alarm and is modulated according to detected type of alarm, when more than one alarm exists output signals alarm with the highest priority.
47	Door Bell	Output, signals door bell for approx. 5 seconds.
48	AUX1 Toggle	Output, whenever F1 is pressed this output switches to opposite state regardless of the setting of AUX1 Timer .
49	AUX2 Toggle	Output, whenever F2 is pressed this output switches to opposite state regardless of the setting of AUX2 Timer .
50	AUX1 Momentary	Output, line is activated for predefined time when F1 key is pressed. The activation time is specified by AUX1 Timer . When AUX1 Timer is set to 00s output it activated for unlimited time - till moment when reader changes its arming mode again.
51	AUX2 Momentary	Output, line is activated for predefined time when F2 key is pressed. The activation time is specified by AUX2 Timer . When AUX2 Timer is set to 00s output it activated for unlimited time - till moment when reader changes its arming mode again.
52	Pulse on Arming	Output, line is activated for predefined time whenever reader is switched to armed mode. Activation time is defined by Pulse on Arming Timer .
53	Pulse on Disarming	Output, line is activated for predefined time whenever reader is switched to disarmed mode. Activation time is defined by Pulse on Disarming Timer .
54	Pulse on Arming and Disarming	Output, line is activated for predefined time whenever reader changes its arming mode. Activation time is defined by Pulse on Arming/Disarming Timer .
55	Tamper Alarm	Output, line is triggered in the moment when Tamper Alarm is raised. Output remains active for time defined by Tamper

		Timer however whenever reader changes its arming mode this output is immediately cleared. When corresponding timer is set to 00s output it activated for unlimited time - till moment when reader changes its arming mode again.
56	Intruder Alarm	Output, line is triggered in the moment when Intruder Alarm is raised. Output remains active for time defined by Intruder Timer however whenever reader changes its arming mode this output is immediately cleared. When corresponding timer is set to 00s output it activated for unlimited time - till moment when reader changes its arming mode again.
57	General Alarm	Output, line is triggered in the moment when Tamper Alarm or Intruder Alarm is raised. Output remain active for a time defined by General Alarm Timer however whenever reader changes its arming mode this output is immediately cleared. When corresponding timer is set to 00s output it activated for unlimited time - till moment when reader changes its arming mode again.
58	Door Unlock Time	Output, line is triggered in the moment when access is granted and remains active for the entire time when door lock is released (same as Door Unlock Time).
59	Door Open Timeout	Output, line is active for the entire time when reader waits for a door to become closed (same as Door Open Timeout).
60	Duress Alarm	Output, line is triggered in the moment when Duress Alarm is raised. Output remains active for time defined by Duress Alarm Timer however whenever reader changes its arming mode this output is immediately cleared.
61	LED STATUS Timer	Output, line is triggered in the moment when reader changes its arming mode and remains active as long as LED STATUS presents actual arming mode.
64	Door Lock Inverted	Output, same as [41]: Door Lock but inverted (normally this output is on, when triggered it goes off).

9 . U S E R P R O G R A M M I N G M O D E

User Programming mode enables management of users registered in the reader (add and delete cards and PIN-s). Alternatively users can be managed with RARC software after connection of reader to computer.

To enter this mode, read one time your MASTER card or enter your MASTER PIN. When in **User Programming** mode, LED OPEN  (green) is on and LED STATUS  lights in red. In **User Programming** mode you have set of programming commands. When you begin to enter any of them, LED SYSTEM  starts flashing and it keeps flashing until this command has been correctly completed. If reader receives no valid input (entries) for more than 10 sec (between the successive steps of the command sequence), it automatically ends the command sequence, however it still remains in **User Programming** mode so that you may return to any user programming command or you may press [#] to exit this programming mode. Alternatively you may wait ~1 min for the reader to leave **User Programming** mode automatically.

Note: Each user ID index consists always of three digits to form ID numbers ranging 000–119. In case you assign a new user the ID that is already occupied by some other user, this will remove the older one from the memory.

9.1.1. User Programming Commands

Note: Any attempt to program an already registered card or PIN will be indicated as a programming error.

[11][PIN][#] – Add NORMAL user with PIN

The new NORMAL user added with this function is stored in unoccupied (free) location of the memory i.e. with unknown ID.

[12][Card 1][Card 2]...[Card N][#] – Add multiple NORMAL users with cards

The reader indicates each successful card reading with an acoustic prompt signal (two beep-s) for the next one to follow. This function is ended automatically if no card is presented within 10 sec from the previous card reading or you can end it earlier by pressing the [#] key. The new users added with this function are stored in unoccupied (free) location of the memory i.e. with unknown IDs.

[13][ID][PIN][#][Card] – Add NORMAL user with ID, PIN and card

The new NORMAL user is registered in the memory at the location indicated by his ID number (ID=000–119). Both, the entered PIN code and presented proximity card are assigned to programmed user. When you want to program only PIN enter: [13][ID][PIN][#][#], when you want to program only card enter: [13][ID][#][Card].

[14][PIN][#] – Add TOGGLE user with PIN

The new TOGGLE user added with this function is stored in unoccupied (free) location of the memory i.e. with unknown ID.

[15][Card 1][Card 2]...[Card N][#] – Add multiple TOGGLE users with cards

The reader indicates each successful reading of the presented card with an acoustic prompt for the next one to follow. This function will be ended automatically if no card is presented within 10 sec from the previous card reading or you can end it manually by pressing [#]. Note, that the new card users added with this function are stored in unoccupied (free) locations of the memory i.e. with unknown IDs.

[16][ID][PIN][#][Card] – Add TOGGLE user with ID, PIN and card

The new TOGGLE user is registered in the memory at the location indicated by the ID number (ID = 000–119). Both, the entered PIN and card are assigned to the user. When you want to program only PIN enter: [16][ID][PIN][#][#], when you want to program only card enter: [16][ID][Card].

[17][PIN][#] – Add TOGGLE LTD user with PIN

The new TOGGLE LTD user is stored in a first unoccupied memory location with entered PIN i.e. with unknown ID.

[18][Card 1][Card 2]...[Card N][#] – Add multiple TOGGLE LTD users with cards

The reader indicates each successful reading of the presented card with an acoustic prompt for the next one to follow. This function will be ended automatically if no card is presented within 10 sec from the previous card reading or you can end it manually by pressing [#]. Note, that the new users added with this function are stored in unoccupied (free) locations of the memory i.e. with unknown IDs.

[19][ID][PIN][#][Card] – Add TOGGLE LTD user with ID, PIN and card

The new TOGGLE LTD user is registered in the memory at the location indicated by ID number (ID=000–119). Both, the entered PIN and the presented proximity card are assigned to the user. When you want to program only PIN enter: [19][ID][PIN][#][#], when you want to program only card enter: [19][ID][Card].

[20] – Delete all users

Reader deletes all users (cards and PIN-s) so that all user IDs are released and can be programmed anew. The MASTER and INSTALLER users are not deleted with this function.

[21][PIN][#] – Delete a PIN

The reader searches its memory for the entered PIN. Once successful it removes the PIN from its memory and the record previously occupied by this PIN is released. This command removes only PIN, if the user has card then it still can be used.

[22][Card] – Delete a card

The reader searches its memory for the presented card. Once successful it removes it from the memory and the record previously occupied by this card is released. This command removes only card, if the user has PIN then it still can be used.

[23][ID] – Delete a user with given ID

A user with entered ID is deleted (both his card and his PIN are removed), a new user can be programmed to use this ID index.

[24][YYMMDDhhmm] – Setting date and time



Where: YY – two last digits of year (00-99), MM – month (01-12), DD – day (01-31), hh – hour (00-23), mm – minute (00-59)

[#] – Exit from User Programming Mode

After exiting from the User Programming mode reader returns to either armed or disarmed mode depending on which one was set prior to User Programming Mode.



Programming Examples

Example 1: Add a new TOGGLE LTD user with a card; programming sequence: [1][8][Card][#] or [1][8][Card][Wait ~10s or press [#]]

- Read your MASTER card or enter MASTER PIN
- The reader enters User Programming mode (LED OPEN  is on and LED STATUS  is on and red)
- Press [1][8]
- LED SYSTEM  starts flashing
- Present a card which you want assign for a new TOGGLE LTD user
- Press [#], command is completed

The reader has completed programming function, however, it has not left User Programming mode so now you can enter another programming command.

Example 2: Delete a user with ID=45; programming sequence: [2][3][0][4][5]

- Read your MASTER card or enter MASTER PIN if you are not in User Programming mode
- The reader enters User Programming mode (LED OPEN  is on and its LED STATUS  is on and red)
- Press [2][3]
- LED SYSTEM  starts flashing
- Press [0]
- Press [4]
- Press [5]
- Press [#], command is completed

The user with ID=45 has been deleted, reader still remains in User Programming mode, so now you can enter another programming command.

10. PROGRAMMING FROM PC

The reader can be fully programmed from the PC through standard COM port (RS232) or via dedicated RUD-1 interface (USB port). In both cases the RARC program is required. In order to establish the connection, select *Options->Port* command in RARC software, then *Connection->Connect...*, the option *RS232* and then the button *Start*.

10.1. PROGRAMMING VIA RS232 COM PORT

In this scenario connection between programmed reader and PC requires four wires: GND, RXD, TXD and RTS as presented on the drawing below. The reader must be supplied from the external source of power.

Note: For programming purpose CLK, DTA and RTS lines must be disconnected from host devices if they were earlier connected.

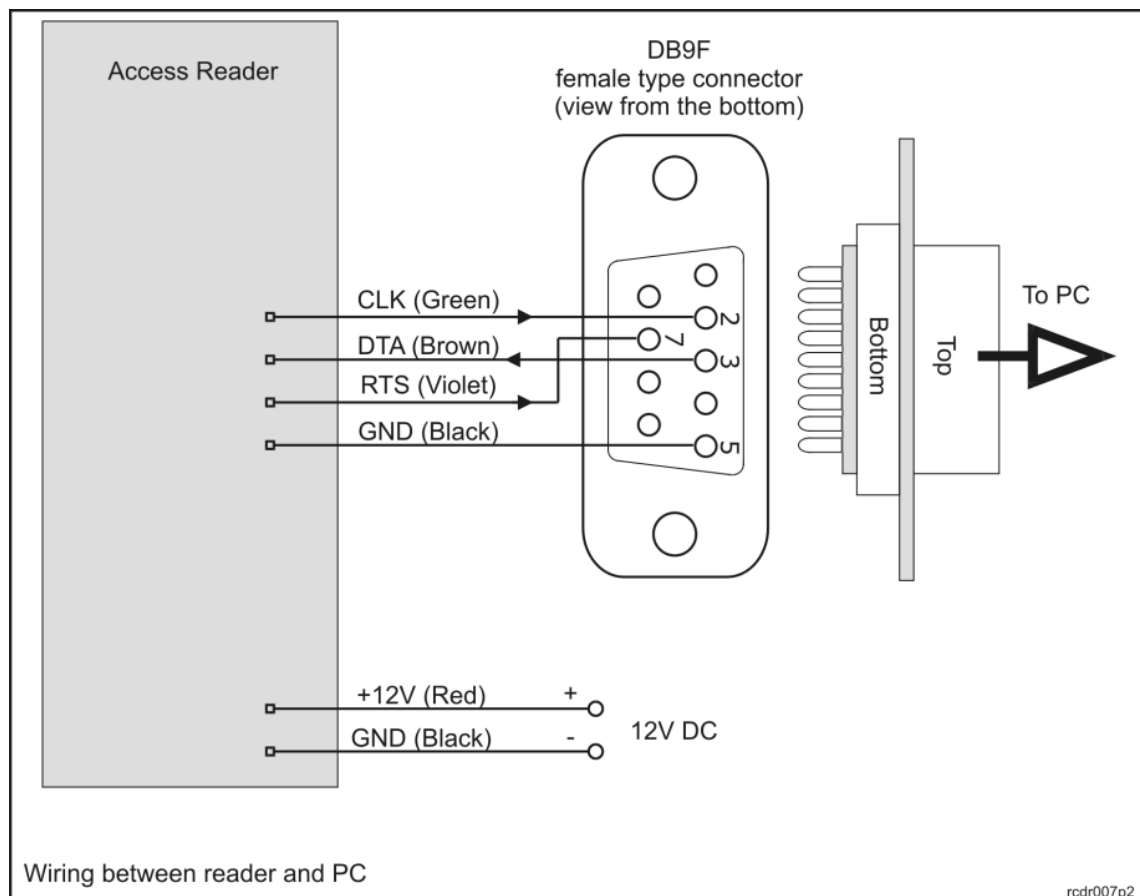

10.2. PROGRAMMING VIA RUD-1 INTERFACE

In this scenario connection between programmed reader and the PC is made through dedicated RUD-1 interface which is also used to power supply programmed reader (no extra source of power is required).

Note: RUD-1 interface can be used for both reader programming and firmware upgrade.

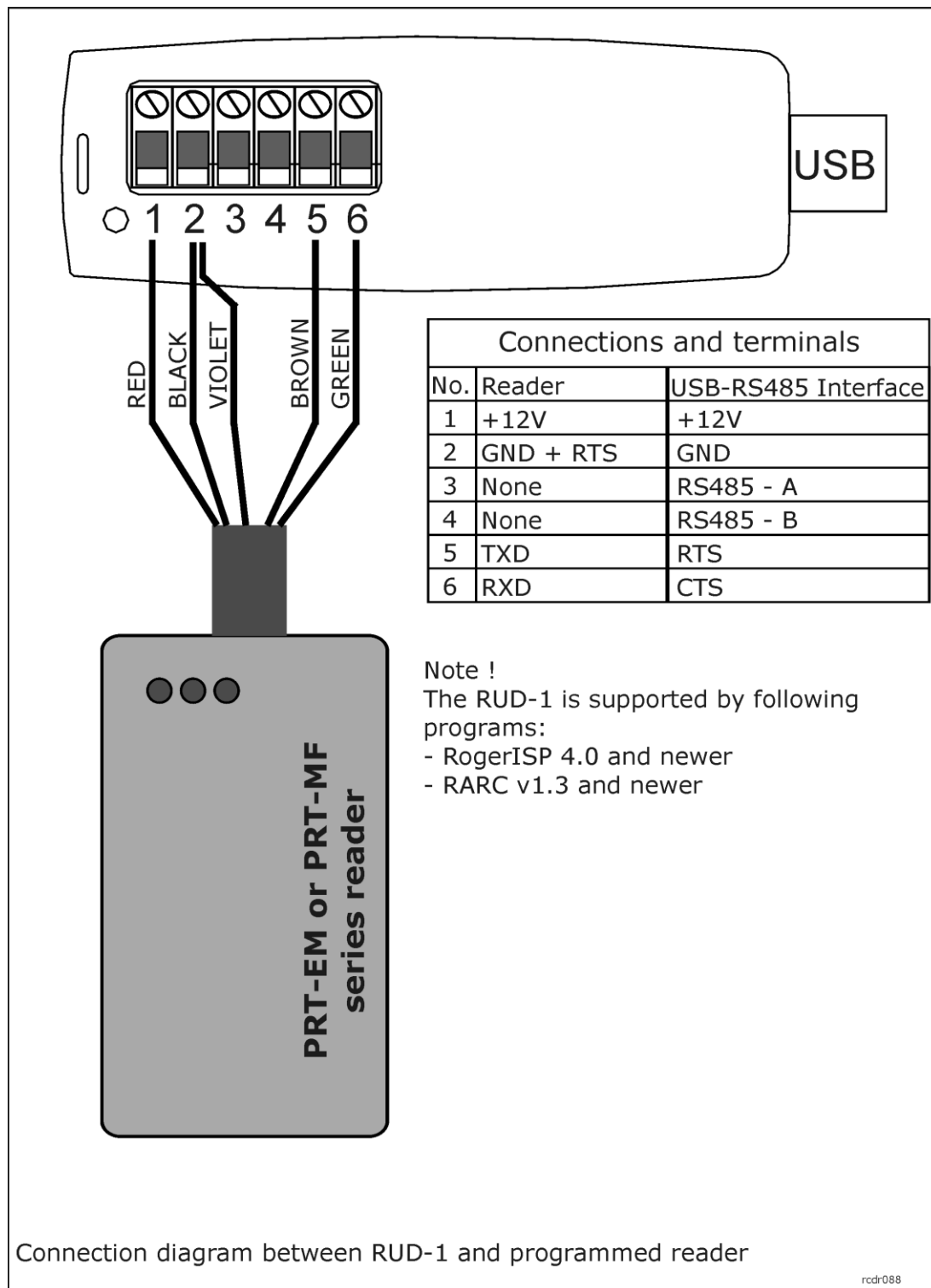

10.3. FIRMWARE UPGRADE

Although the factory new reader is programmed with the latest firmware version available, it can be later upgraded with a newer one. Roger design team continuously develops functionality enhancements for the products allowing new firmware versions to be released periodically (for every new firmware version available check our www.roger.pl website). Customers are kindly advised to register at the website so that Roger can send information as soon as new firmware versions is ready for download.

Firmware can be uploaded to reader via ordinary RS232 COM port or RUD-1 (USB) interface. In both cases RogerISP 4 program is required.

Note: Once the firmware upgrade is accomplished but programmed device doesn't work then it may be necessary to start Memory Reset procedure and/or upload the firmware once more.

10.3.1. Firmware upgrade via RS232 COM port

- Connect reader to PC's COM port as explained in section 10.1
- Power up the reader (device must be supplied from external source of power)
- Place jumper on FDM contacts
- Restart the reader (short RST contacts for while)
- Start RogerISP program and select COM port you have connected the reader
- Optionally click *Erase* button, RARC program will detect device type, select proper communication protocol (you should see *P89 series duplex, 19200* in the bottom of the RogerISP program) and erase current firmware
- In *Firmware* text window select file with the new firmware (file extension: HEX) then click *Program*
- Once the new firmware is uploaded, remove jumper from FDM contacts and restart the reader (disconnect power for while or short RST contacts for a moment)
- Configure the reader manually or from PC

10.3.2. Firmware upgrade via RUD-1 interface

- Connect reader to RUD-1 interface as explained in section 10.2
- Place jumper on FDM contacts
- Start RogerISP program and select COM port with the RUD-1
- Optionally click on *Erase* command, RARC program will detect device type, select proper communication protocol (you should see *P89 series duplex, 19200* in the bottom of the RogerISP program) and will erase current firmware
- In *Firmware* text window select file with the new firmware (file extension: HEX) then click *Program*
- Once the new firmware is uploaded, remove jumper from FDM contacts and restart the reader
- Configure the reader manually or from PC

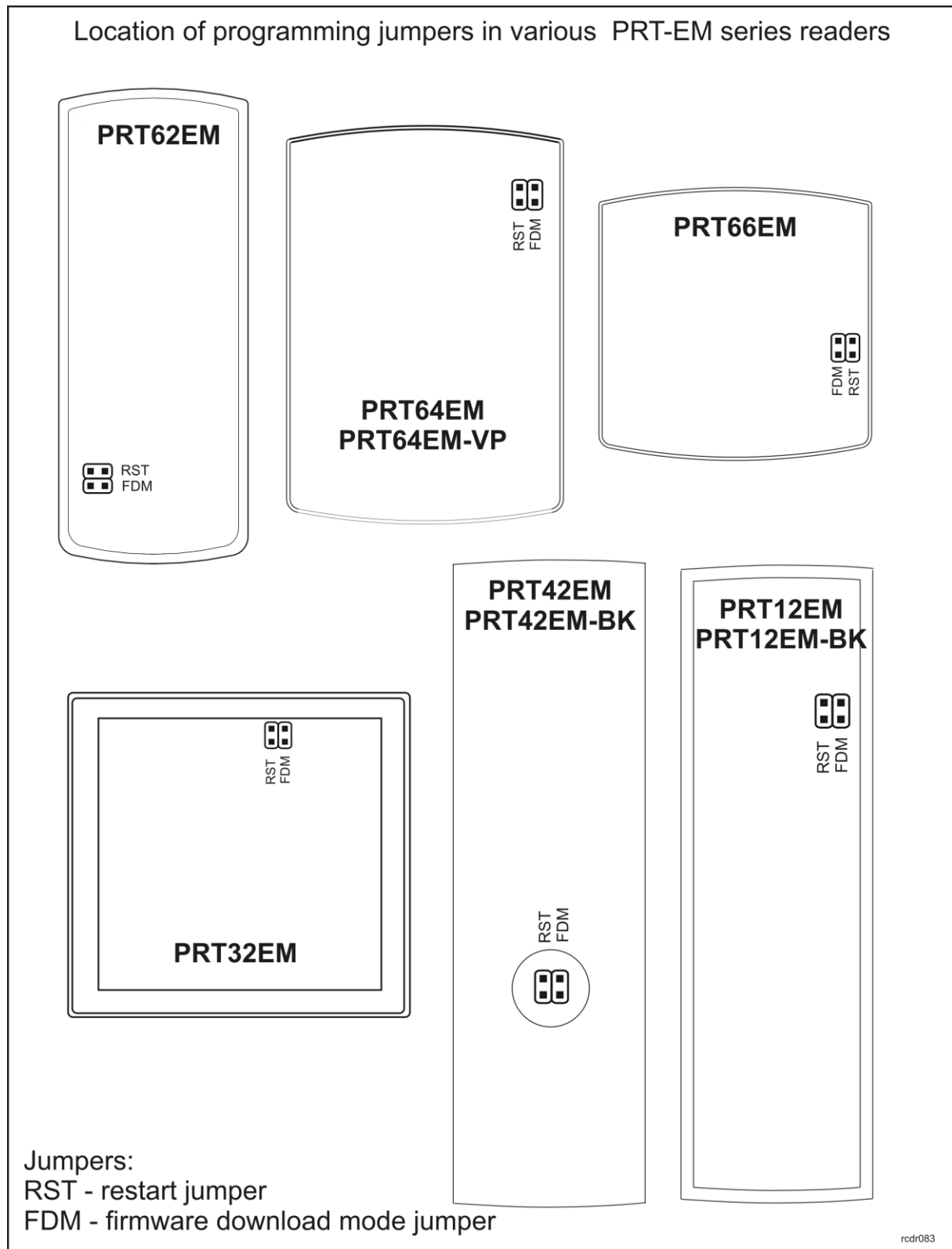

11. INSTALLATION GUIDELINES

- Reader should be installed in such way as to ensure physical access to the connection cable, screw terminals and programming jumpers.
- Before the reader will be mounted in desired location it is recommended to configure its operating mode and if required to program the MASTER and INSTALLER users.
- Any EM125kHz proximity card can be programmed as MASTER or INSTALLER card.

- When lost or stolen a new MASTER and INSTALLER cards (PIN-s) can be reprogrammed in the reader.
- When the reader has been set for **Terminal Mode** (online unit connected to the host controller), programming of MASTER and INSTALLER users can be skipped.
- A new factory delivered unit is configured with **[030] Offline mode, Simple Standalone.**
- The reader should be mounted near the supervised door on a vertical piece of supporting structure.
- Disconnect power supply before making any electrical connections.
- Be aware that the installation of reader directly on the metal type surface will reduce card reading distance.
- For installations on a metal surface you can place a non-metallic 10 mm thick spacer (a plastic/plaster plate etc.) between the reader and the supporting structure.
- For installations with two readers to be mounted on the opposite sides of the same wall and aligned along the same geometrical axis, place a metal plate between them and make sure none of two readers has direct contact with it (allow min. 10 mm space). Be aware that the reading distance will be reduced.
- For best results mount the proximity readers at least 0.5 m apart.
- When using separate power supply sources, short all power supply negatives (ground).
- It is recommended to ground the negative power supply line (only at one point).
- With its relatively weak electromagnetic field generation, reader should not cause any harmful interference to operation of other equipment. However, its card reading performance can be affected by other interference generating devices, especially radio waves emitting equipment or CRT computer monitors.
- If card reading performance of the reader deteriorates (e.g. reduced reading range or incorrect readings) consider relocation.
- In standalone mode, always connect a general purpose diode (e.g. 1N4007) in parallel to a door lock and place the diode as close as possible to the lock.

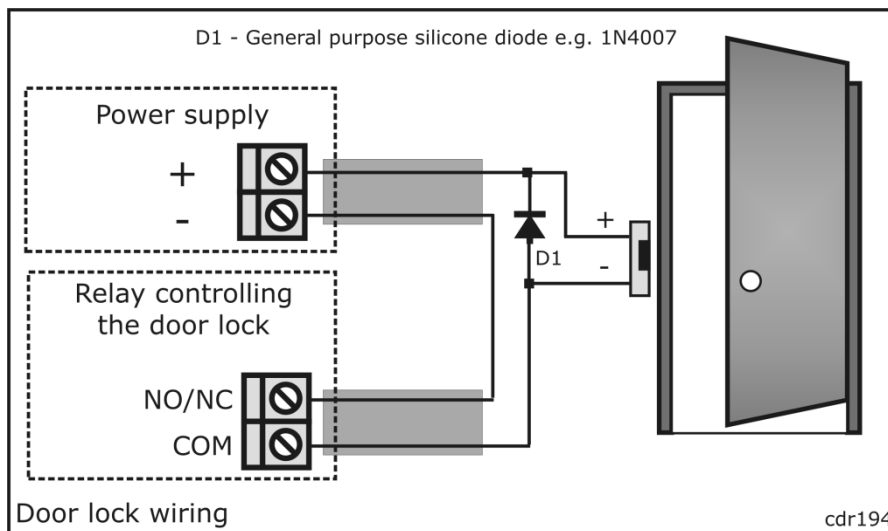

Screw terminals and wires				
Wire Color	Label	Standalone Modes (Offline Modes)		Terminal Modes (Online Modes)
		Simple Standalone Mode	Full Standalone Mode	
Green	CLK	Configured as input or output, programmable function	CLOCK communication line	DATA 0 line for Wiegand, CLOCK for Magstripe and RACS, TXD for RS232

Brown	DTA	Configured as input or output, programmable function	DATA communication line	DATA 1 line for Wiegand, DATA for Magstripe and RACS, RXD for RS232
Yellow	IN1	Input line, programmable function		In Wiegand and Magstripe this line by default controls LED OPEN  . In RACS format the line can block card reading and PIN entering. Line is active when shorted to ground
Blue	IN2	Input line, programmable function		In Wiegand and Magstripe this line by default controls internal buzzer of the reader. Line is active when shorted to ground
Gray-Pink	Relay NC	Relay output 1.5A 24V DC/AC, programmable function		not used
Red-Blue	Relay COM			
Pink	Relay NO			
Violet	RTS	RTS line for RS232		
Red	+12V	Supply input plus		
Black	GND	Supply input minus, also reference ground for RS232		
Grey	TAMP	Tamper switch contacts, normally closed, isolated, 24V/50mA. Contacts becomes open when unit is detached from the place of installation or upper part of enclosure is open.		
White				

Technical Specification	
Nominal supply voltage	12VDC
Nominal current consumption	PRT12EM: 65mA PRT12EM-BK: 45mA PRT62EM: 45mA PRT64EM: 65mA PRT64EM-VP: 85mA PRT66EM: 45 mA
Reading distance	PRT62EM: up to 12 cm, PRT64EM-VP: up to 8 cm, other: up to 15 cm Note: Reading distance is defined for good quality proximity cards placed in optimal position against the reader. For all PRTxxEM readers except PRT64EM-VP the optimal card position is in the front of the reader (card surface parallel to front of the reader). For PRT64EM-VP the optimal position for card reading is from the left and right side of the reader's enclosure.
Anti-sabotage protection (Tamper)	NC contact, 50mA/24V
Proximity cards	EM 125KHz (EM4100/4102 compatible)
Communication distance	Between access controller and PRT reader: max. 150 m Between main PRT reader and external PRT reader: max. 150 m Between main PRT reader and XM-2 expander: max. 150 m

IP Code	PRT12EM/PRT12EM-BK: IP65 PRT62EM: IP65 PRT64EM: IP65 PRT66EM: IP65 Note 1: The IP65 rating is guaranteed if the bottom of the housing is tightly adhered to the surface on which the device is installed. It is the installer's responsibility to seal the space between the bottom of the housing and the surface on which the device is mounted.
Operating environment	Outdoor-general, temperature: -25°C- +60°C, relative humidity: 10 to 95% (non condensing)
Dimensions H x W x D	PRT12EM/PRT12EM-BK: 150.5 X 46 X 23 mm PRT62EM: 100 X 45 X 25 mm PRT64EM/PRT64EM-VP: 115 X 80 X 35 mm PRT66EM: 85 X 85 X 27 mm
Weight	PRT12EM/PRT12EM-BK: 150g PRT62EM: 100g PRT64EM: 120g PRT64EM-VP: 470g PRT66EM: 120g
Compliance	CE, RoHS

Ordering Codes	
PRT12EM	Outdoor proximity reader with keypad, laser engraved long durability silicon rubber keypad, two function keys, dark grey ABS enclosure, pig-tail cable
PRT12EM-BK	The same as PRT12EM but without keypad
PRT62EM	Outdoor, miniature proximity reader without keypad, dark gray ABS enclosure, pig-tail cable
PRT64EM	Outdoor proximity reader with keypad, laser engraved long durability silicon rubber keypad, two function keys, dark grey ABS enclosure, screw terminals, pig-tail cable as option
PRT64EM-VP	Outdoor proximity reader with keypad, laser engraved long durability silicon rubber keypad, two function keys, silver metal enclosure including key-tops, pig-tail cable
PRT66EM	Outdoor proximity reader without keypad, dark gray ABS enclosure, screws terminals, pig-tail cable as option
XM-2	Input/output addressable expander in plastic enclosure, digital communication with reader, two NO/NC inputs and two relay outputs, each relay offers single NO/NC contact 1.5A/24V rated
XM-2-BRD	XM-2 electronic module (board) only
PE-1	Plastic enclosure for XM-2/RM-2 modules

Product History			
Electronic module	Firmware	Date	Description

v1.0	fv1.20	11/12/07	The initial product version
v1.0	fv1.23	11/02/08	No change
v1.0	fv1.24	17/03/08	Time range for Door Unlock Time and Door Open Timeout extended to 99 minutes. Programming functions [51] and [52] removed and replaced by functions [71] and [72]
v1.0	fv1.25	19/05/08	CLK line operation in Simple Standalone Mode corrected; Door Bell indication on internal buzzer and output corrected
v1.0	Fv1.29	16/02/2010	Extended functions in standalone mode and EPSO protocol. Adjustment of keypad backlight and buzzer loudness level available.
v2.0	Fv 2.29	16/02/2010	Extended functions in standalone mode and EPSO protocol. Adjustment of keypad backlight and buzzer loudness level available.

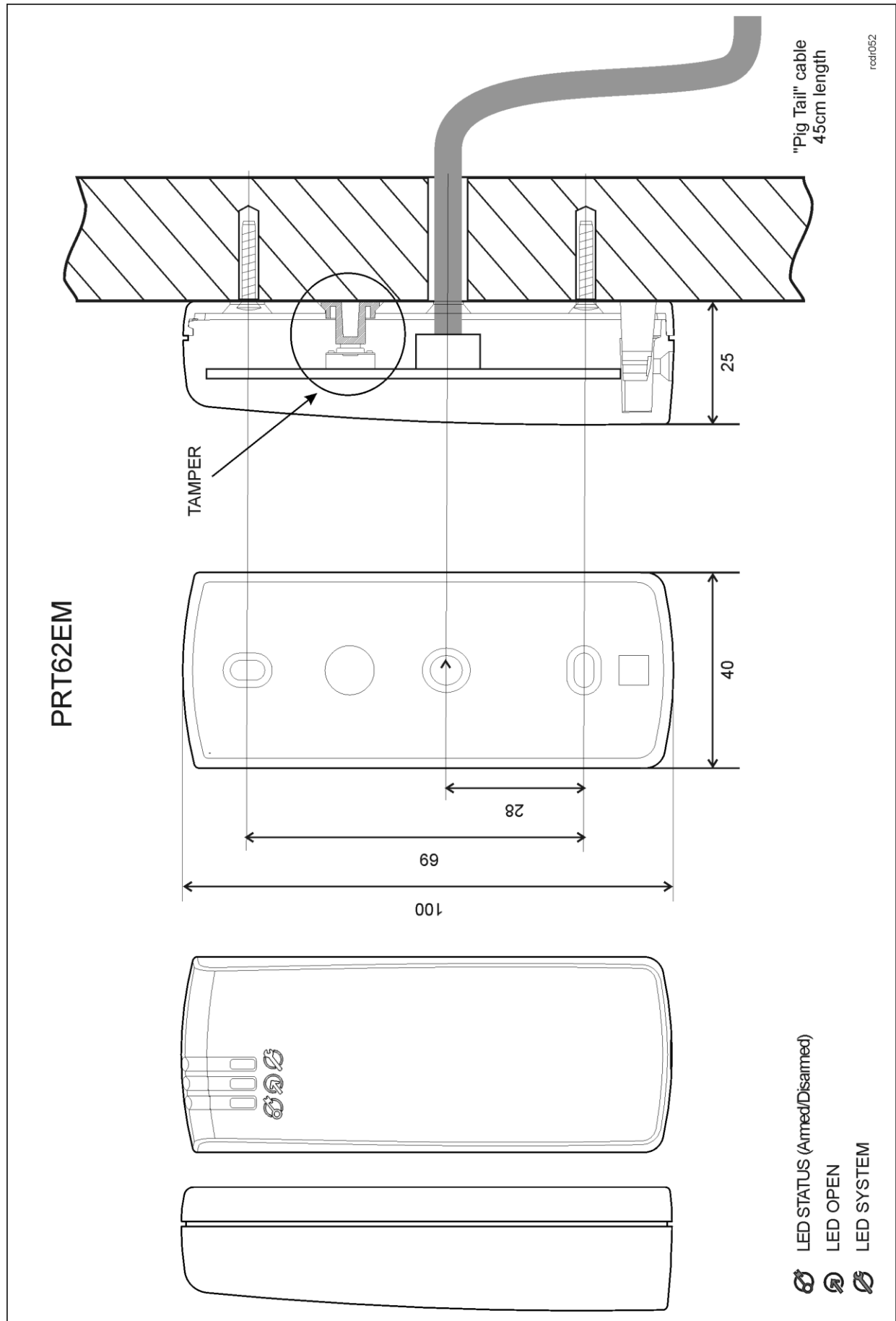

PRT66EM

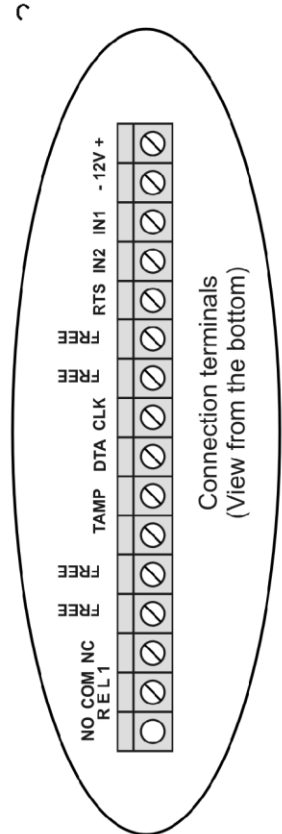
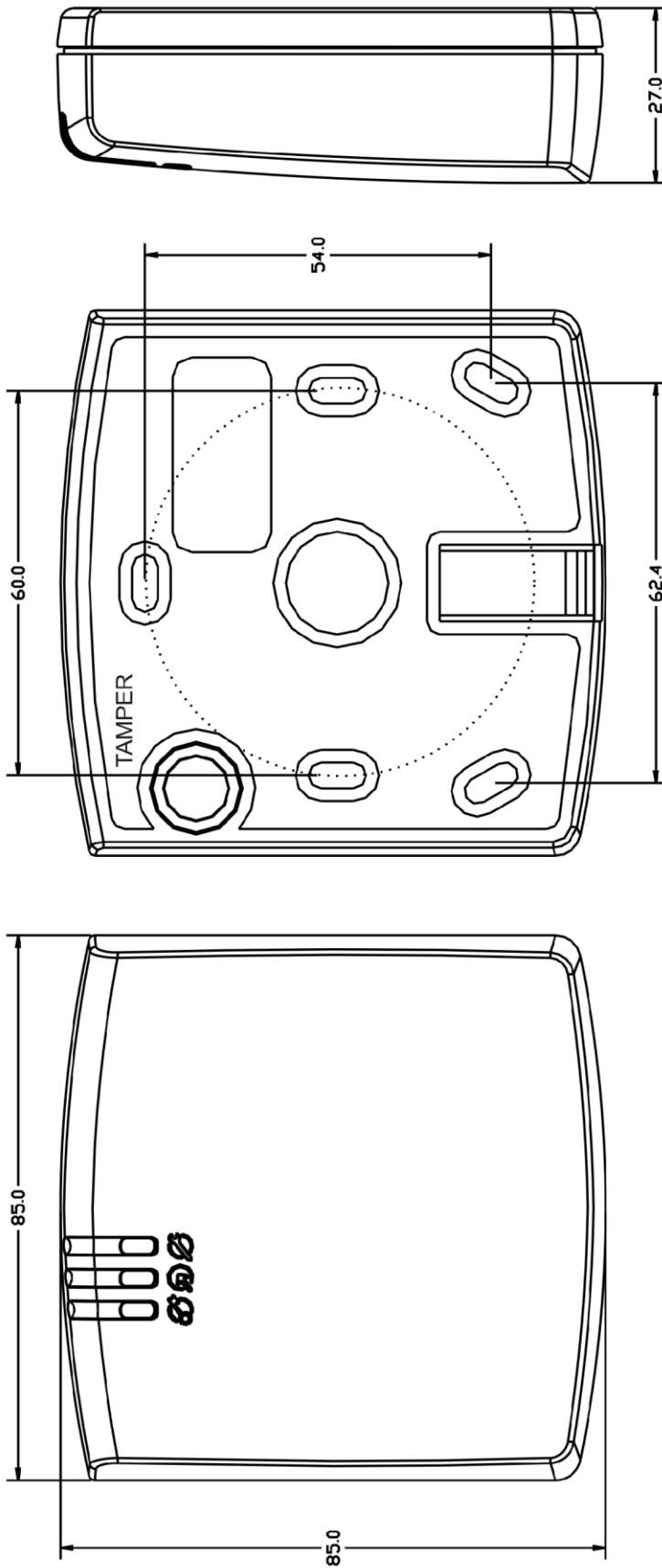

- LED STATUS (Armed/Disarmed)
- LED OPEN
- LED SYSTEM

rod054

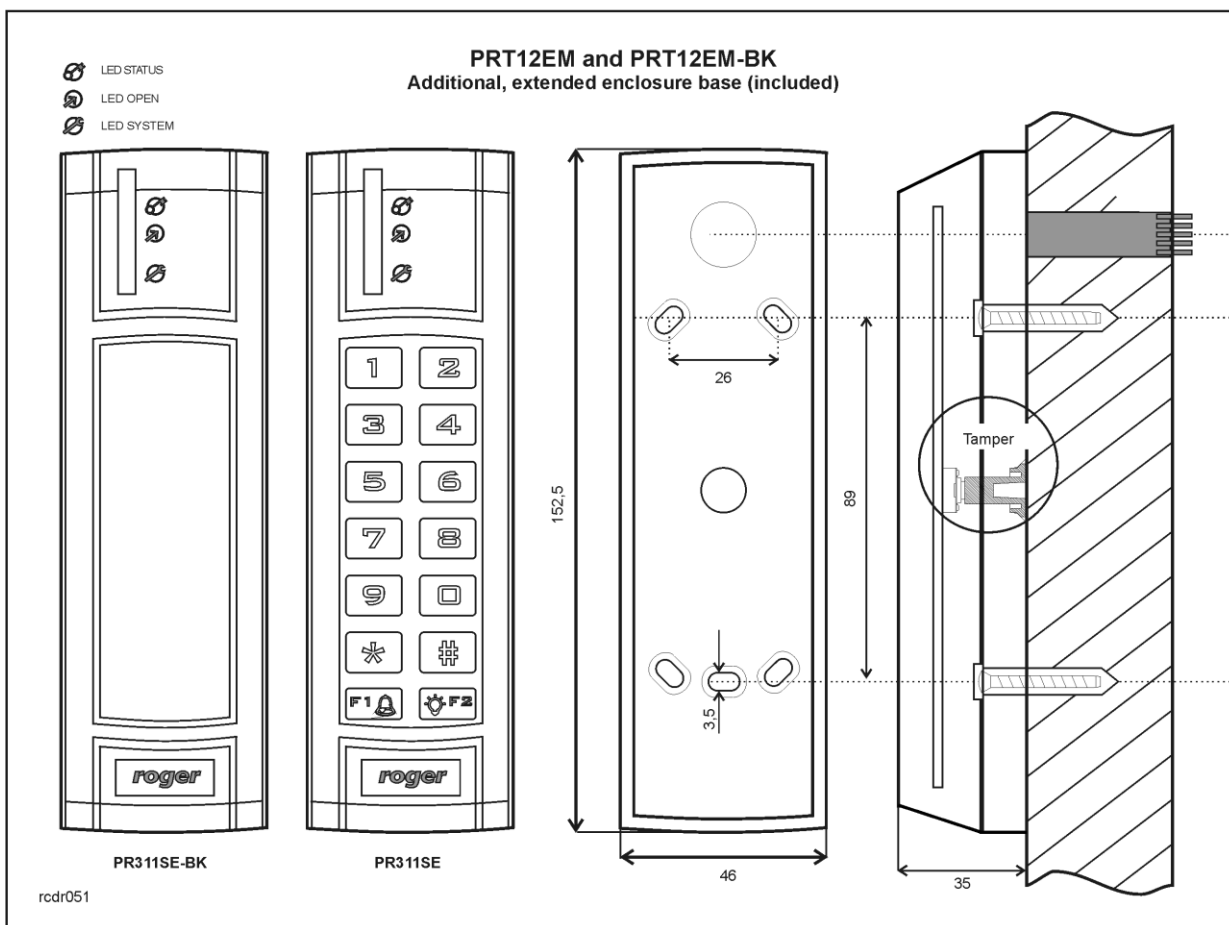
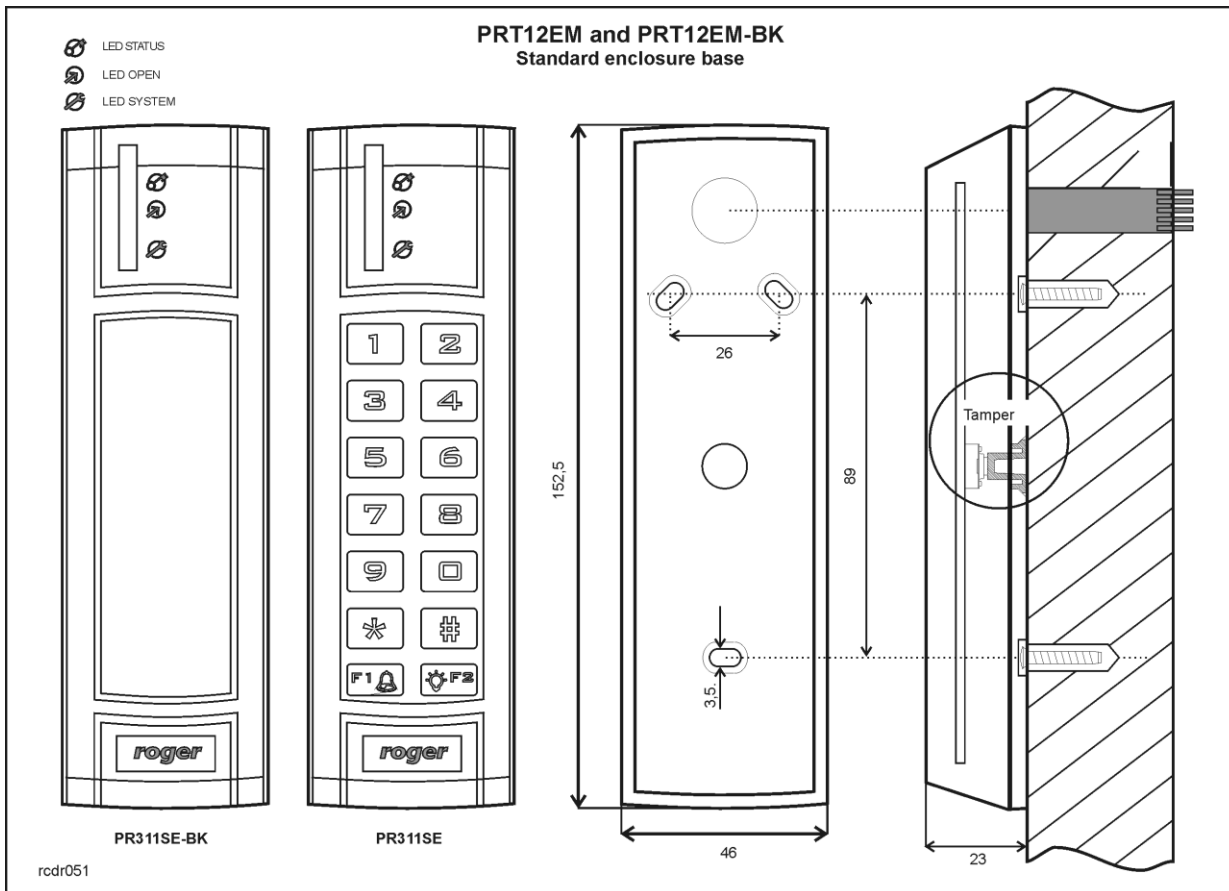

PRT-EM and PRT-MF series readers operation in Online Mode

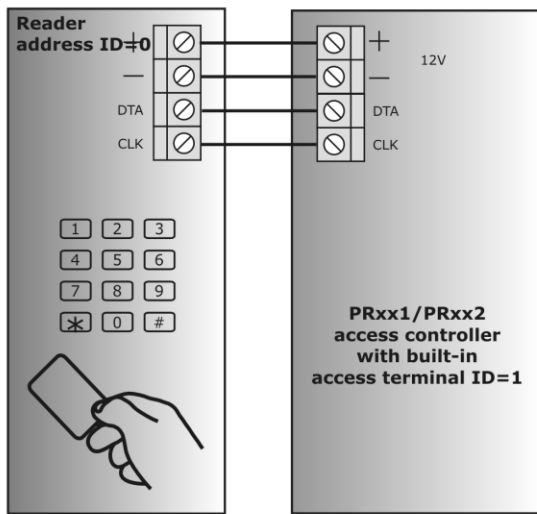

Connection to PRxx1/PRxx2 series access controller with built-in ID1 terminal

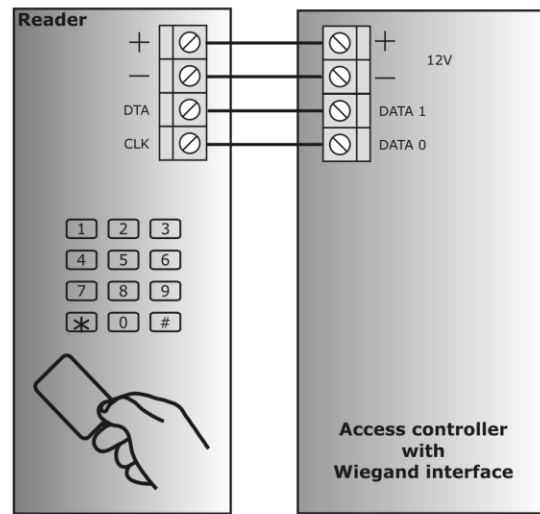

Connection to access control unit with Wiegand interface

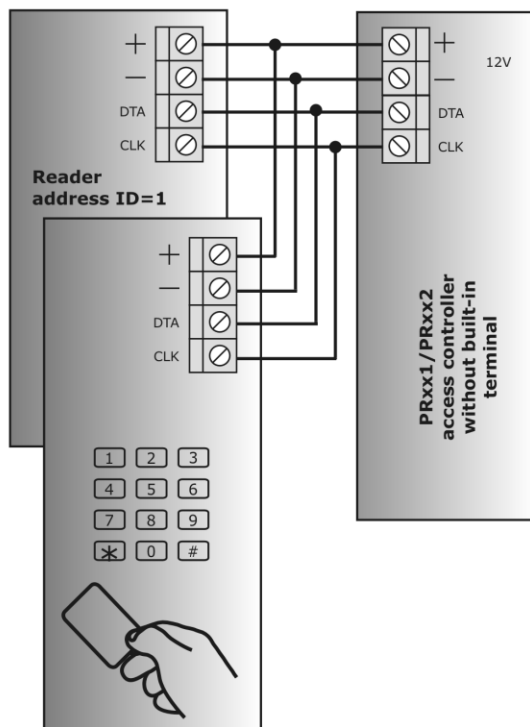

Connection to PRxx1/PRxx2 series access controllers (two-way door control)

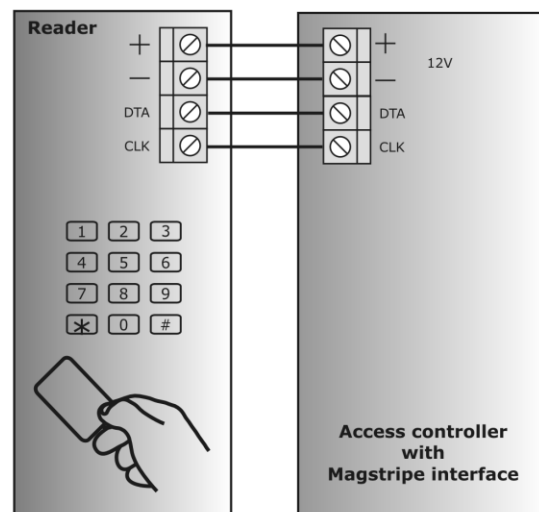

Connection to access control unit with Magstripe interface

rcdr060

PRT-EM and PRT-MF series readers in Simple Standalone Mode
(sample only)

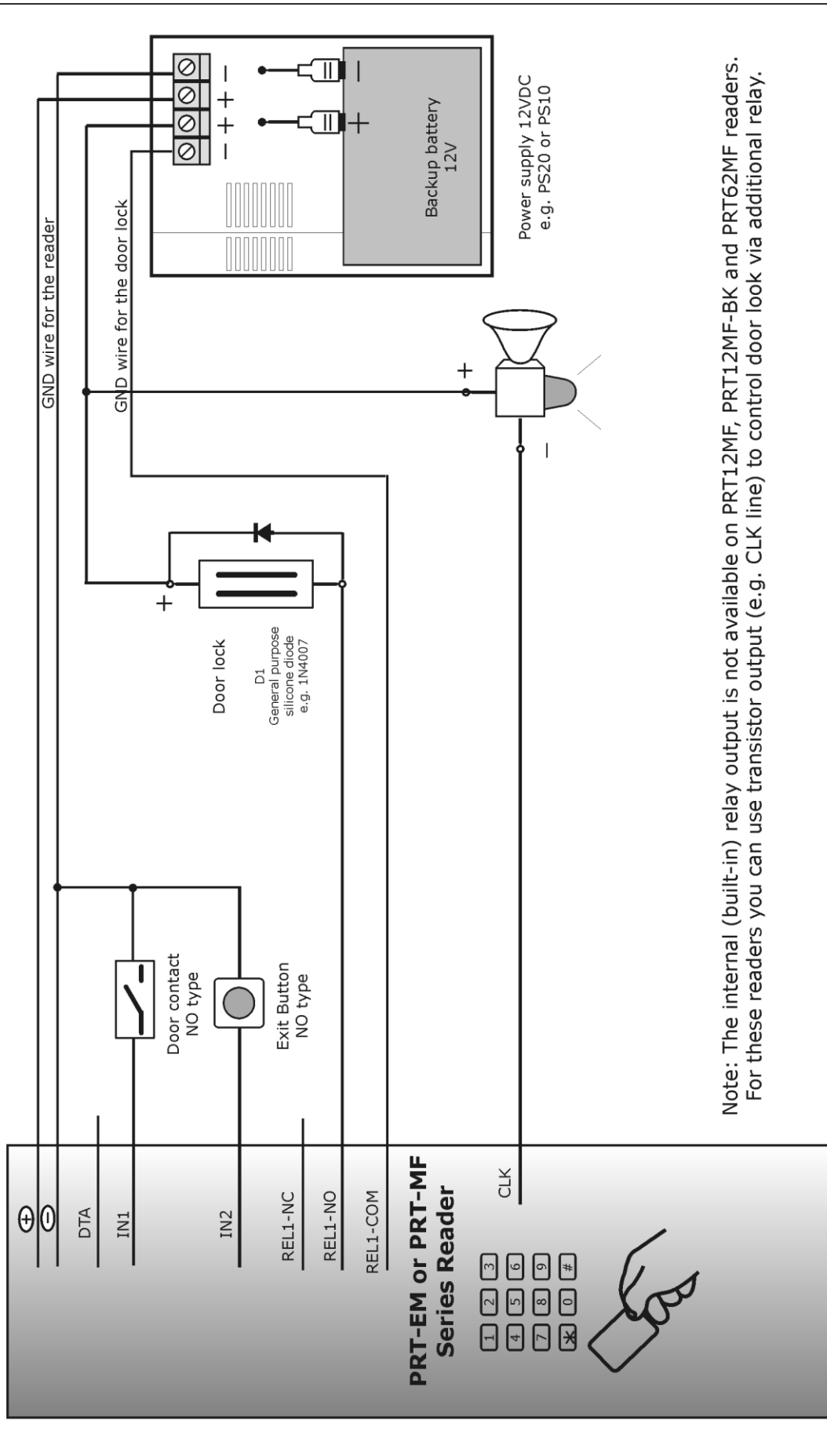

Note: The internal (built-in) relay output is not available on PRT12MF, PRT12MF-BK and PRT62MF readers. For these readers you can use transistor output (e.g. CLK line) to control door lock via additional relay.

rcdr055

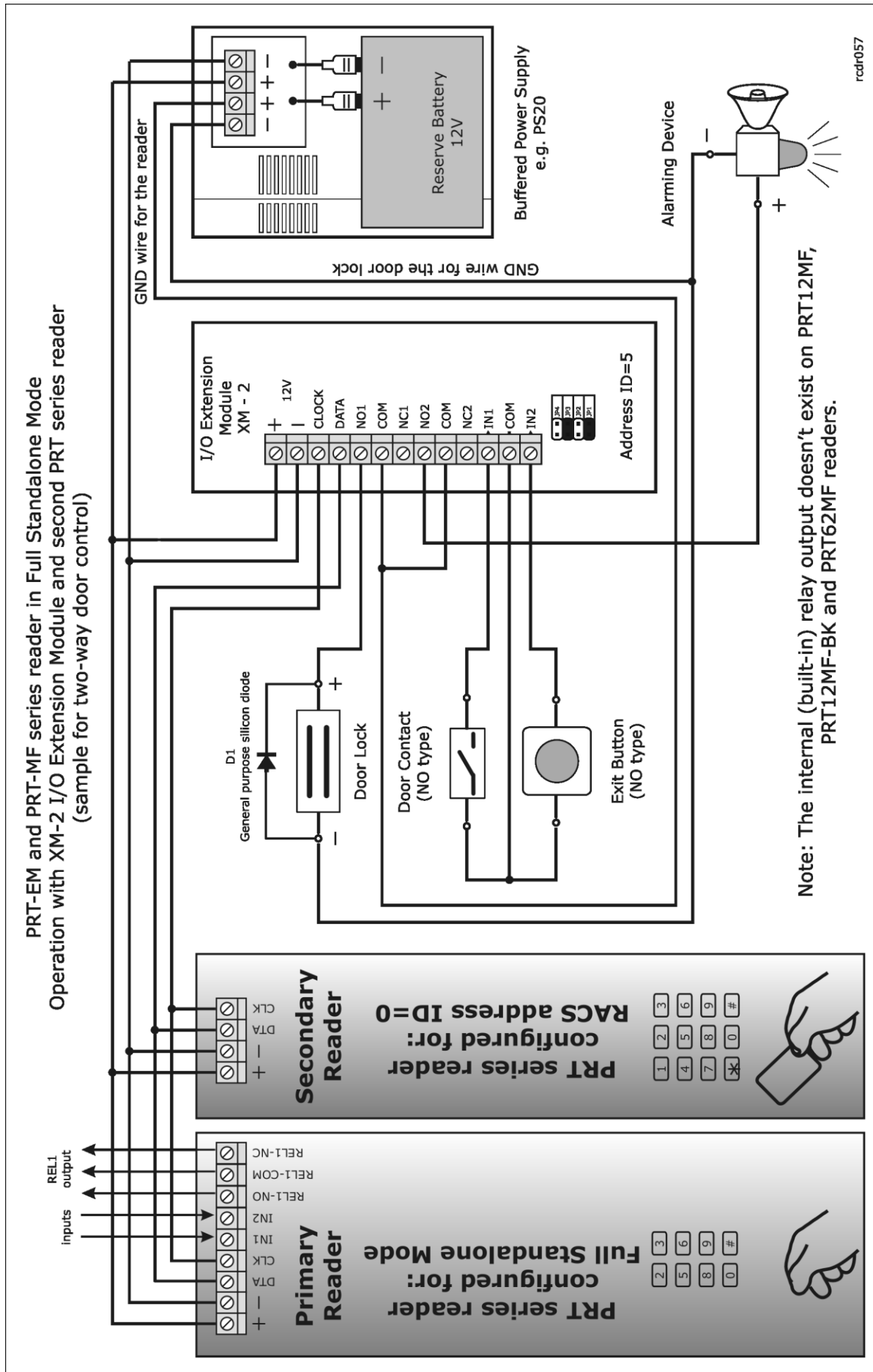

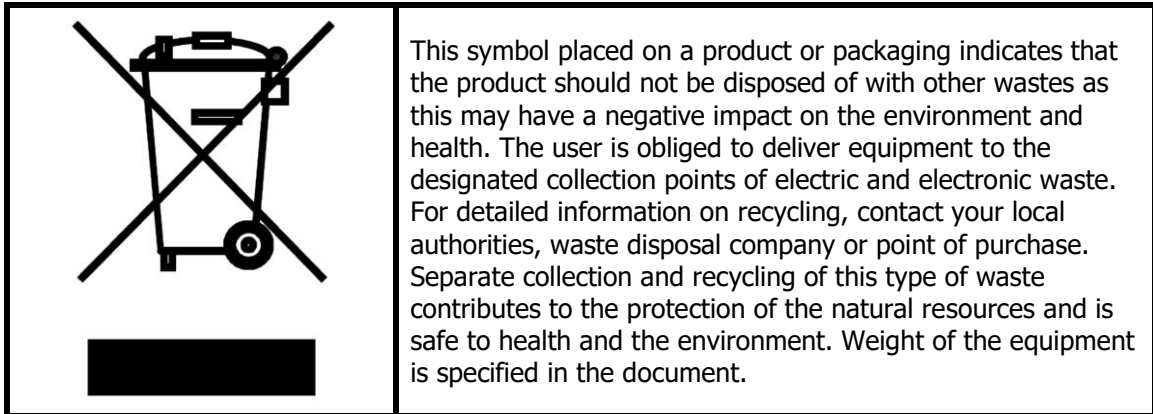
**Contact:****Roger sp. z o.o. sp.k.****82-400 Sztum****Gościszewo 59****Tel.: +48 55 272 0132****Fax: +48 55 272 0133****Tech. support: +48 55 267 0126****E-mail: support@roger.pl****Web: www.roger.pl**