

Installation guide for
PR302 v2.1
Rev. H

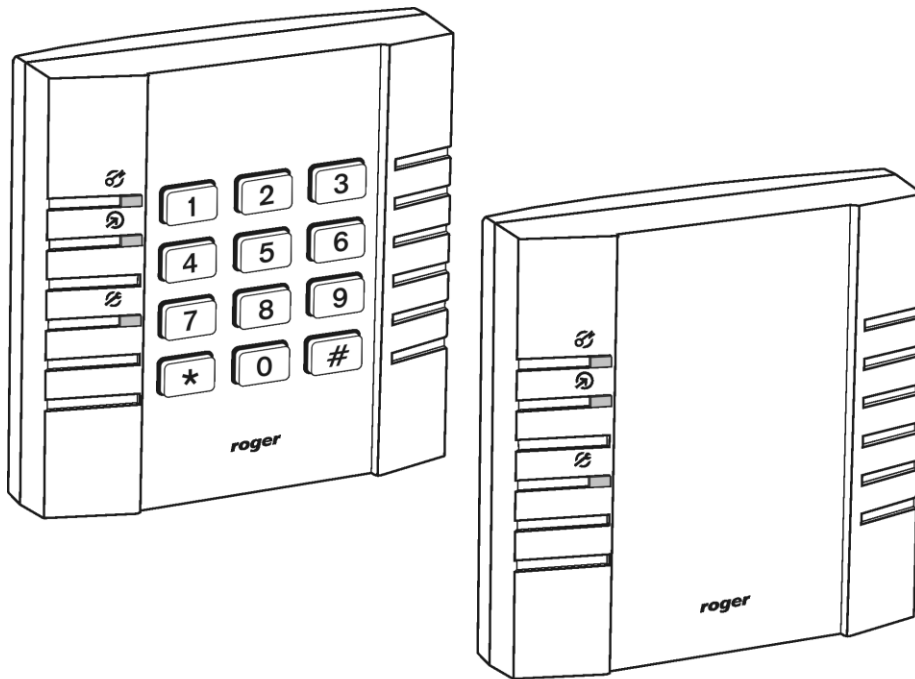

rchr065

Introduction

This document contains minimum information required for electrical installation of PR302 access controller.

Installation

The PR302 can be installed in indoor location only. In particular, it is not allowed to install the reader in places with high humidity such as saunas, swimming pools, car washes, etc. All electrical connections must be made before power supply will be applied. Factory new unit is configured for address ID=00 and has programmed MASTER PIN (1234) and MASTER card (delivered with the new device).

The MASTER card/PIN can be used for initial testing of the controller - the single use of MASTER card/PIN activates momentarily REL1 output (for approx. 4s); double, consecutive use of MASTER card/PIN changes controller's arming mode and switches IO1 output to reverse state.

All devices working in one access system and connected to the same RS485 communication bus should have common minus (common GND). This can be achieved by connecting all supply minuses using additional (separate) wire or connecting each supply minus with earth, however the second method might create problems when electrical potentials of the earth are not the same in different parts of the electric installation.

Note: It is forbidden to short positive outputs (DC+) from various sources of power and/or other DC outputs available in the system.

Setting address

Before controller will be connected to communications bus it should be configured to individual address (ID number=00..99). The controller's address can be set manually using **Memory Reset** procedure or from PC computer. In order to set/change controller's address from PC connect it to any free COM port and then using PR Master program enrol it to database. Once the unit is found by PR Master use relevant command to change its address and then disconnect it from PC and connect to designated access installation.

Note: Connecting two or more controllers with the same address will cause communications conflict on the communication bus.

Power supply

Controller requires 10-15VDC supply and consumes 100mA average current. The power source should provide DC voltage free of interferences. Using poor quality switched mode power sources can cause reduction of card reading distance. Always carefully calculate wire gauge used to supply access controller, note that amount of current required by controller can rise momentarily up to 200mA. The GND input to controller is also reference ground for RS485 com. bus and for all signal lines used in controller.

Door Lock

In most cases door locks are inductive type loads and generate strong voltage surges when switching to off state. This phenomenon can corrupt electronic circuits and change its behaviour. In order to protect access controller from these effects, every inductive load (like door lock or any other coil) should be protected with silicon diode (e.g. 1N4007) connected as close as possible to the switched device. Also, door locks should be wired using separate pair of wires connected directly to the source of power.

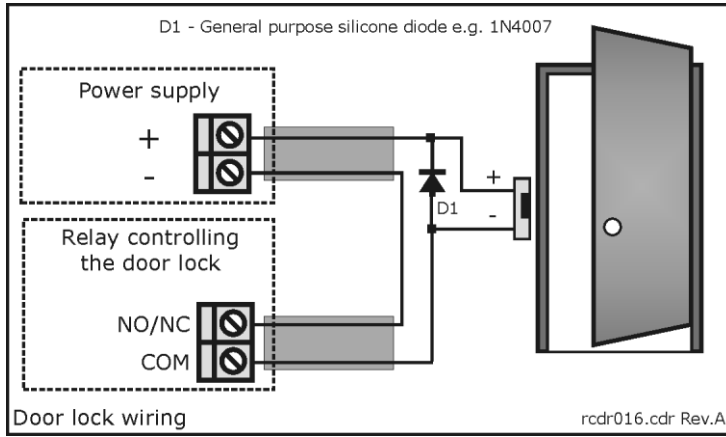

Inputs

The PR302 offers three programmable inputs (IN1, IN2 and IN3). All of them have the same electrical structure and can be configured as NO or NC line. Each input is internally biased to supply plus (+12V) through 15kΩ resistor what makes that supply plus is observed on the free (not connected) input. The NO type input goes active when shorted to supply minus (GND). The NC line in normal state should be connected to GND, it became triggered when connection with GND is discontinued.

Relay output

The PR302 has one programmable relay output (REL1) which offers single NO/NC/COM contact 24V/1.5A rated. In normal state NC contact is shorted to COM while NO remains isolated. When active, NO is shorted to COM while NC remains isolated. When controller is not supplied or supplied with voltage below its minimum level, relay output remains not active.

Transistor outputs

There are two transistor outputs (IO1 and IO2) available on the PR302 controller, both have identical electrical structure. When not active (normal state) transistor outputs represent high impedance, when active (triggered state) outputs short to supply minus (GND). Each output can switch max. 1A DC while voltage connected to it must not exceed 15VDC. The IO1 and IO2 have internal over-current protection which switches them off for currents above 1A.

Communication bus

The communications bus consist of three lines: A, B and cable’s shield (SHLD). Electrically, it represents RS485 standard however neither the daisy chain structure nor terminating resistors are required. Instead of this free topology of communication bus is allowed, the A/B wires can be laid down using “three”, “star” or any combination of them. It is recommended to use UTP cable for A and B lines however other types of signal cables are accepted as well. The use of shielded cables should be limited to these installation were strong electromagnetic interferences are expected.

The max. cable distances:

- between communication interface and any controller on the bus: 1200m
- between communication interface and CPR network controller (if installed): 1200m
- between any access controller and CPR network controller (if installed): 1200m

When longer cable lengths are required the UT-3 (RS485/RS422 repeater) or UT-4 interfaces can be used. Using link built from two UT-3 units communication distance can be extended by 1200m while using UT-4 serial-to-ethernet converter distance is limited to area covered with computer network.

Connecting readers and extension modules

Access terminals (readers) and extension modules (e.g. XM-2, XM-8) can be connected to controller through CLK and DTA lines. Controller can operate either with Roger access terminals (using RACS data output format) or with any other type of readers which are equipped with Wiegand or Magstripe interfaces. Any type of signal cable can be used for CLK and DTA lines. Each device connected to controller through CLK/DTA line must have its individual address (0..15) however this rule is valid for devices using RACS format but not for Wiegand or Magstripe interfaces.

Note: Normally, the maximum guaranteed cable length between controller and any other device connected to CLK/DTA line is limited to 150m nevertheless when using RACS interface communication will run satisfactory for up to 500m distances, however it is not guaranteed in every case.

For best card reading results controller should be installed on non metal surface. When installed on metal structure the reading range can be reduced up to 50%. This effect can be reduced by placing non metal spacer (min. 10mm thick) between controller and metal surface where controller is installed. Readers should be installed on at least 0.5m distance from each other, also two readers should not be aligned along the same geometrical axes.

Connecting Wiegand and Magstripe readers

Follow schematic drawing below when connecting Wiegand or Magstripe readers to controller. Note, that to prepare the controller for operation with those type of readers you must make adequate settings in PR Master program.

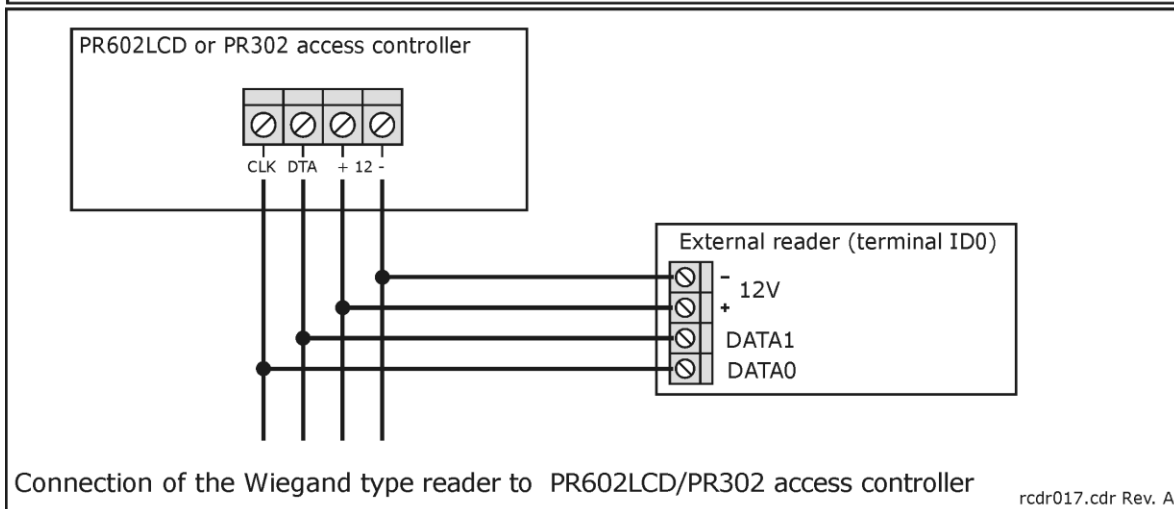
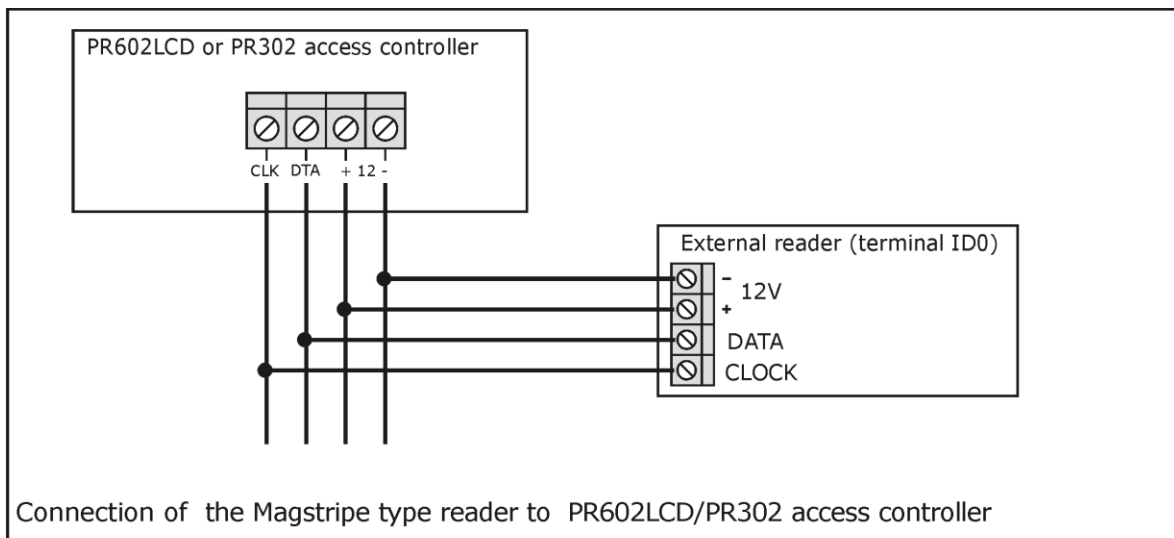

rcdr017.cdr Rev. A

Memory Reset

Memory Reset procedure enables erasing of current settings and returning to default factory settings. Full procedure also allows to program new MASTER card/PIN as well as new address of the controller. After Memory Reset procedure, the controller automatically enters normal working mode.

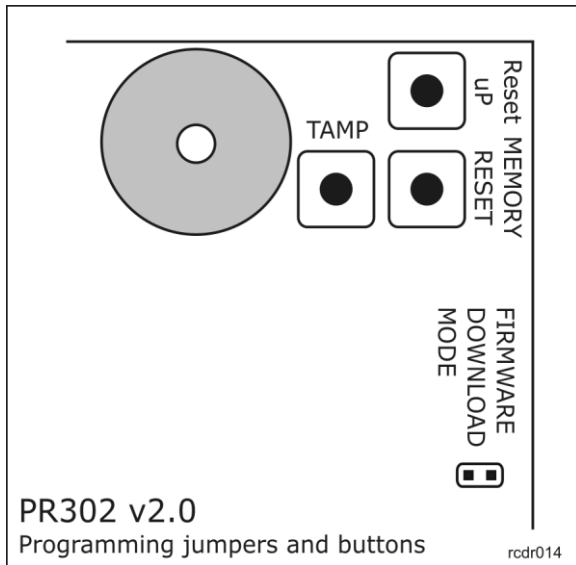

Simplified Memory Reset procedure (firmware 2.18.6 or newer)

Simplified Memory Reset restores default settings and automatically sets controller address ID=00. MASTER card and PIN cannot be configured.

- Remove connections to CLK and DTA terminals of the controller
- Connect CLK terminal with DTA terminal
- Press and hold MEMORY RESET button until LED OPEN  (green) pulsates
- Release MEMORY RESET button
- Disconnect CLK and DTA terminals
- After a few seconds the controller shall restart automatically and switch to normal mode

Simplified Memory Reset procedure (firmware older than 2.18.6)



Simplified Memory Reset restores default settings and enables programming of new MASTER card while controller address is automatically configured as ID=00.

- Press and hold MEMORY RESET button until LED OPEN  (green) pulsates
- Release MEMORY RESET button
- Read any card at the controller — this will be a new MASTER card
- After a few seconds the controller shall restart automatically and switch to normal mode

Full Memory Reset procedure

Full Memory Reset restores default settings and enables programming of new MASTER card, MASTER PIN and controller ID address.

- Press and hold MEMORY RESET button until LED OPEN  (green) pulsates
- Release MEMORY RESET button
- Enter new MASTER PIN (3-6 digits) followed with the [#] key or skip this step and press only the [#] key
- Read any card at the reader — this will be a new MASTER card or skip this step and press only the [#] key
- Enter two digits (in range of 00 to 99) by means of keypad – this will be new ID address or skip this step and press only the [#] key so the default ID=00 could be assigned
- After a few seconds the controller shall restart automatically and switch to normal mode

After Memory Reset, controller resumes its work with default factory settings and entered address. You can then initially test its operation using the MASTER card or PIN (if available). Using the MASTER card/PIN once activates the REL1 output for 4 seconds (LED OPEN  is on for the time when REL1 is active). Using of MASTER card/PIN twice switches the IO1 output to the opposite state and changes arming mode (LED STATUS  changes its colour).

Note: If current address of the controller is hardware type (FixedID) then address entered within Memory Reset procedure is ignored.

Firmware upgrade

During manufacturing process controller is programmed with latest version of firmware, nevertheless it can be later upgraded with newer versions. Roger design team continuously work on enhancements so the new firmware versions are released quite often (every new firmware version is published on www.roger.pl). Our customers are advised to register at web site so Roger will let inform when new versions are ready for download. The new firmware can be downloaded without removal of the controller from live installation. The detailed description of firmware upgrade procedure can be found in *Firmware upgrade.pdf* on www.roger.pl.

The new firmware is programmed into the controller by means of communication bus and doesn't require de-installation of the unit from its original location. For firmware upgrade the RogerISP program is required. Once the controller is upgraded it should be fully reconfigured, also it is necessary to update the RACS database which must be aligned with current version of controller's firmware (command **...Networks/Controllers/Commands/Restart controller and verify version..**).

Note: Whenever new firmware is uploaded into the unit the PR Master program should be also upgraded to latest available version.

Connection terminals	
Name	Function
+12V	Power supply plus
0V (GND)	Power supply minus, also reference ground for inputs, RS485 and CLK/DTA lines
IN1	IN1 input, internally pulled to supply plus through 15kΩ resistor
IN2	IN2 input, internally pulled to supply plus through 15kΩ resistor
IN3	IN3 input, internally pulled to supply plus through 15kΩ resistor
SHLD	RS485 cable's shield
RS485 A	RS485 communication bus, line A
RS485 B	RS485 communication bus, line B
CLK	RACS Clock & Data interface, line CLOCK
DTA	RACS Clock & Data interface, line DATA
TAMPER	Tamper switch, line A, 24V/50mA rated
TAMPER	Tamper switch, line B, 24V/50mA rated
IO2	IO2 transistor output 15VDC/1.0A
IO1	IO1 transistor output 15VDC/1.0A
REL1-NC	REL1 output, normally closed contact, 24V/1.5A rated
REL1-COM	REL1 output, common contact, 24V/1.5A rated
REL1-NO	REL1 output, normally open contact, 24V/1.5A rated

Technical specification	
Supply voltage	Nominal 12VDC, min./max. range 10-15VDC
Current consumption	average 80 mA
Anti-sabotage	Isolated contact, NC type, 24V/50mA rated, IP67
Reading distance	UP to 12 cm for ISO card (depends on card type)
Cards	EM 125 KHz (EM4100/4102 compatible)
Environmental class (according to EN50131-1)	Class I, Indoor, temperature: +5°C- +40°C, relative humidity: 10 to 95% (non-condensing)
Ingress protection	IP 30
Dimensions	105 X 105 X 31 mm
Weight	~ 140g
Approvals	CE, RoHs

Ordering information	
PR302	PR302 access controller
RM-2	Relay module with plastic enclosure, the RM-2 offers two relays with one NO/NC contact 24V/1.5A rated, relay contacts are protected by over-voltage components, each relay can be triggered by applying supply plus or minus, the maximum amount of current required to trigger relay is less than 5mA, two LEDs to indicate triggering of relevant relay
RM-2 PCB	RM-2 PCB module without enclosure
XM-2	Input/output addressable extension module with plastic enclosure, digital communication according to RACS Clock and Data protocol, two NO/NC inputs and two relay outputs, each relay offers one NO/NC contact 24V/1.5A rated, relay contacts protected by over-voltage components, two LEDs to indicate triggering of relevant relay
XM-2 PCB	RM-2 PCB module without enclosure
UT-2	RS232-RS485 communication interface
UT-2USB	USB-RS485 communication interface
UT-4	Ethernet-RS485/RS232 communication interface
UT-4DR	Ethernet-RS485 communication interface

Contact:
Roger sp. z o.o. sp.k.
82-400 Sztum
Gościszewo 59
Tel.: +48 55 272 0132
Fax: +48 55 272 0133
Tech. support: +48 55 267 0126
E-mail: support@roger.pl
Web: www.roger.pl

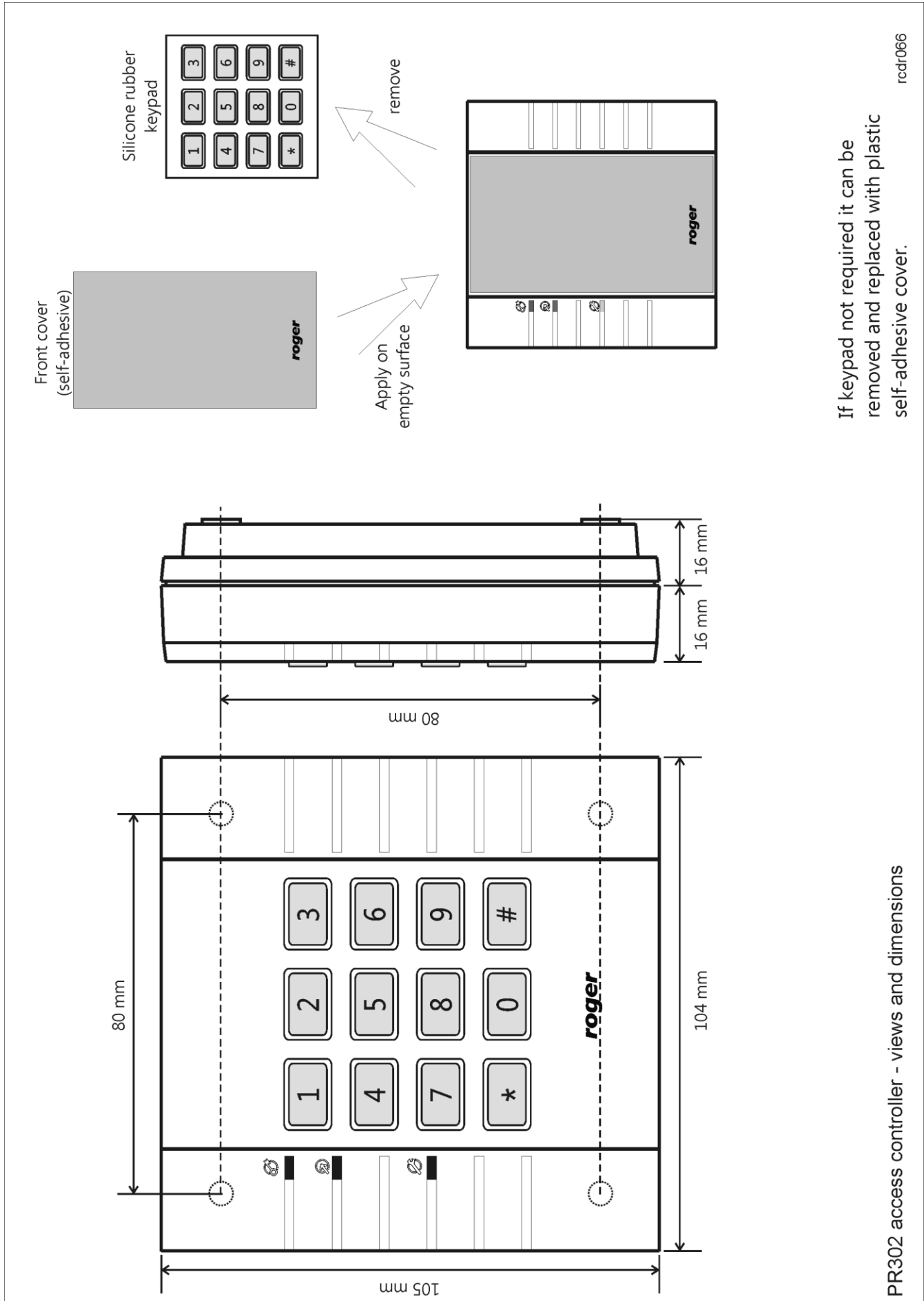

If keypad not required it can be removed and replaced with plastic self-adhesive cover.

PR302 access controller - views and dimensions

rcdr066

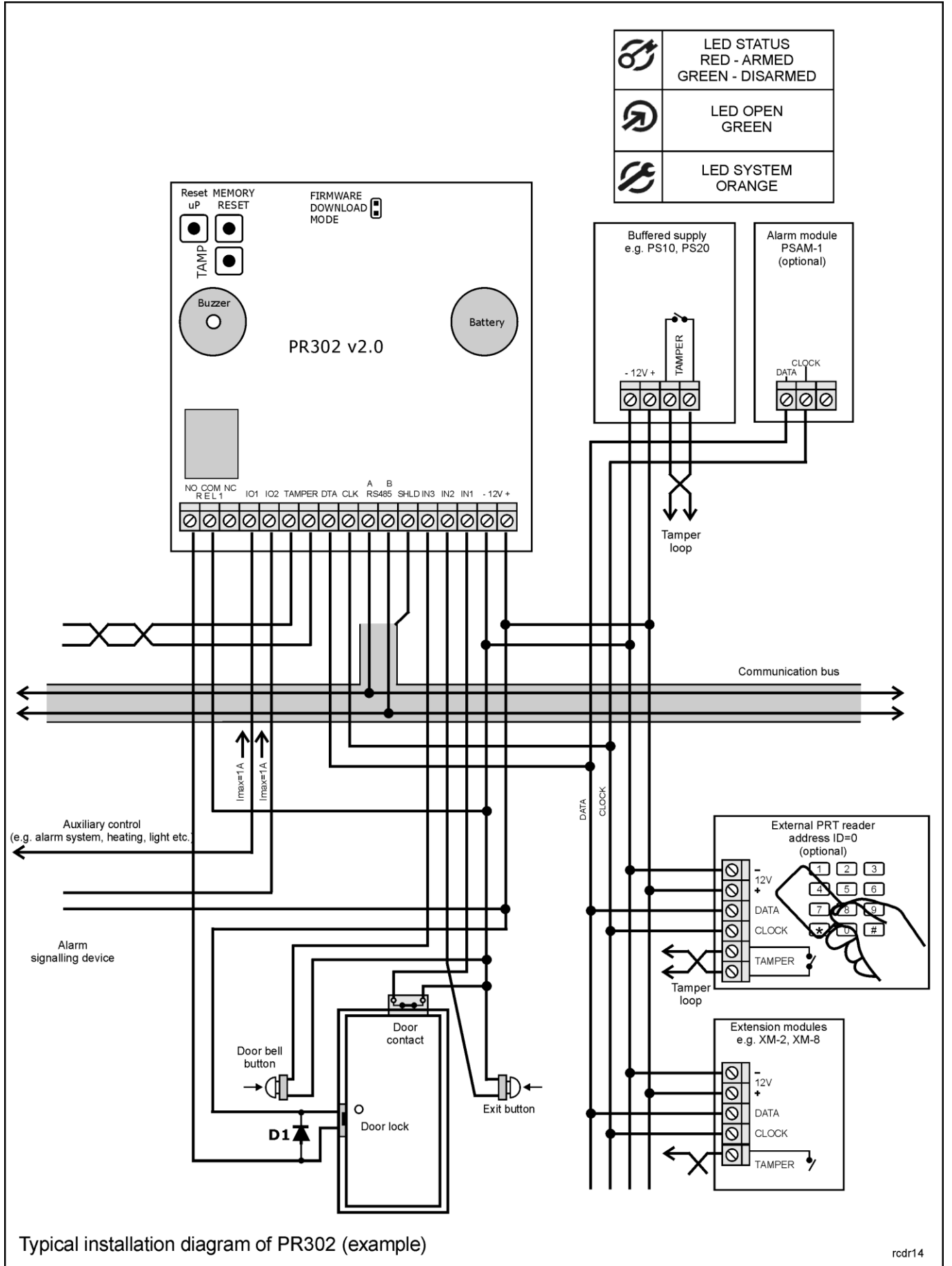

Typical installation diagram of PR302 (example)

rcdr14