

# Roger Access Control System

## Installation guide for PR402DR/PR402DR-BRD Access Controllers

Firmware version: 2.10.1612

Document version: Rev. A

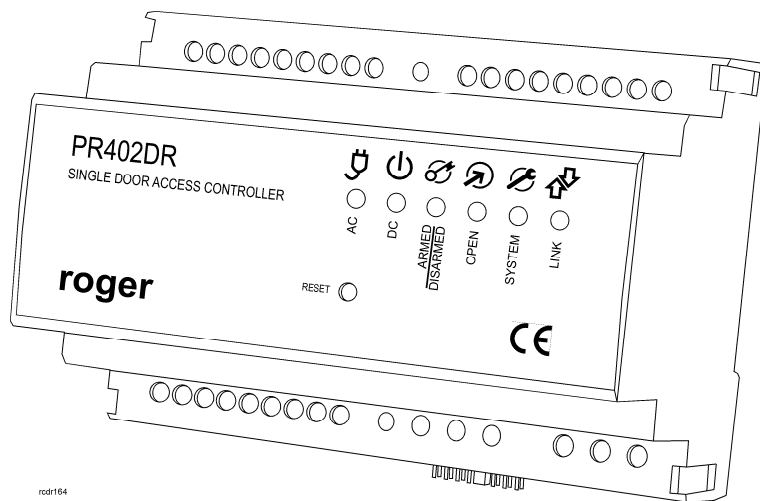

rcdr164

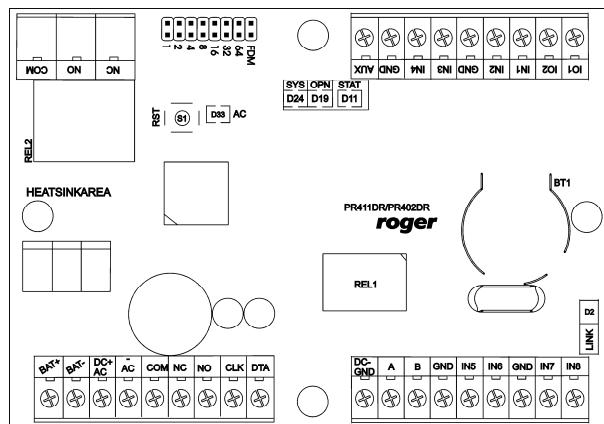

# Contents

<b>1. Introduction</b> .....	<b>3</b>
1.1 This manual .....	3
1.2 Typing conventions.....	3
<b>2. Description and Specification</b> .....	<b>4</b>
<b>3. Installation</b> .....	<b>5</b>
3.1 Terminals and connection diagram.....	5
3.2 Front panel .....	8
3.2.1 PR402DR controller .....	8
3.2.2 PR402DR-BRD controller.....	8
3.3 Power supply .....	9
3.4 Connection of door lock .....	10
3.5 Connection of readers and modules .....	11
3.5.1 PRT series readers and extension modules.....	11
3.5.2 Wiegand readers .....	12
3.6 Input and output lines .....	13
3.6.1 Inputs.....	13
3.6.2 Relay outputs .....	13
3.6.3 General purpose outputs .....	13
3.7 RS-485 communication bus .....	13
3.8 Installation guidelines .....	14
3.9 PR402DR-BRD template in 1:1 scale.....	14
<b>4. Configuration</b> .....	<b>16</b>
4.1 Controller address .....	16
4.2 Memory Reset procedure .....	17
4.3 Controller programming .....	18
4.4 Firmware update .....	18
<b>5. Ordering information</b> .....	<b>19</b>

# 1. INTRODUCTION

## 1.1 This manual

This manual contains minimum information that is necessary to properly install the devices and to perform initial tests. Full functional description of the controllers has been included in the document - PRxx2 series controllers, Functional description and programming guide. Whereas PR Master software, which is used for access control system management is described in detail within the manual for that software. Both documents are available at [www.roger.pl](http://www.roger.pl).

If PR402DR and PR402DR-BRD controllers are not clearly distinguished in particular paragraph, then information specified for PR402DR are also valid for PR402DR-BRD. But if PR402DR-BRD name is used in particular paragraph then the information concerns only that specific type of controller.

## 1.2 Typing conventions

*Examples*

italics letters

Specific names related to RACS 4 system

with first capital letter

---

Notes

---

separated with two lines (upper, lower) from the standard text

## 2. DESCRIPTION AND SPECIFICATION

Both controllers, PR402DR and PR402DR-BRD are identical in regard of their functions, but differ mechanically. PR402DR is installed inside plastic enclosure fitted to mounting on DIN 35 mm rail, while PR402DR-BRD is just a PCB module without enclosure. Both controllers replace discontinued PR402-BRD, which is the same as PR402DR and PR402DR-BRD in regard of their functions.

The new, factory-made controller has the address ID=00 and is equipped with the MASTER card which can be used for the initial tests after installation of the controller and connection of external reader. In case of PR402DR, the section of 35mm DIN rail is included and it can be used to fix controller in the box, which is not equipped with DIN 35mm rail.

PR402DR is not equipped with built-in reader and it requires connection of external reader operating in RACS Clock&Data standard (PRT series terminals), Wiegand 26...66bit standard or Magstripe standard.

The controller can be programmed by means of PC with PR Master software. It is not possible to program the controller manually but certain command are available and they can entered by means of keypad at external reader. The commands are used for controlling/setting and not programming. The PR402DR can be connected to PC by means of communication interface i.e. UT-2, UT-2USB, UT-4DR or RUD-1.

---

Note: The PR402DR requires PR Master 4.4.2.xxx or higher.

---

<b>Table 1. Specification</b>	
Supply voltage	18 VAC; 12VDC; 24VDC
Backup battery	13.8V/7Ah, charging current app. 300mA
Current consumption	Average: 100 mA (only PR402DR, excluding readers and other load points connected to AUX terminal)
Input lines IN1..IN8	NO/NC inputs, electrically biased to +12V via 15 kΩ resistor, triggering level app. 3.5V
REL1 output	Relay output with single NO/NC contact, 30V/1.5A max. load
REL2 output	Relay output with single NO/NC contact, 230VAC/5A max. load
Output lines IO1/IO2	Open collector transistor outputs, internally biased to +12V via 15 kΩ resistor, when active short to ground, 15VDC/1A max. load
Distances	Between controllers (RS485 comm. Bus): up to 1200m Between the reader and controller: max. 150 m Between controller and XM-2/XM-8 expansion modules: max. 150 m
Environmental class (according to EN 50131-1)	Class I, indoor general conditions, temperature: +5°C to +40°C, relative humidity: 10 to 95% (no condensation)
Dimensions HxWxD	PR402DR: 85x124x73mm PR402DR-BRD: 80x115mm
Weight	PR402DR: approx.. 200g PR402DR-BRD: approx. 100g
Certificates	CE

### 3. INSTALLATION

#### 3.1 Terminals and connection diagram

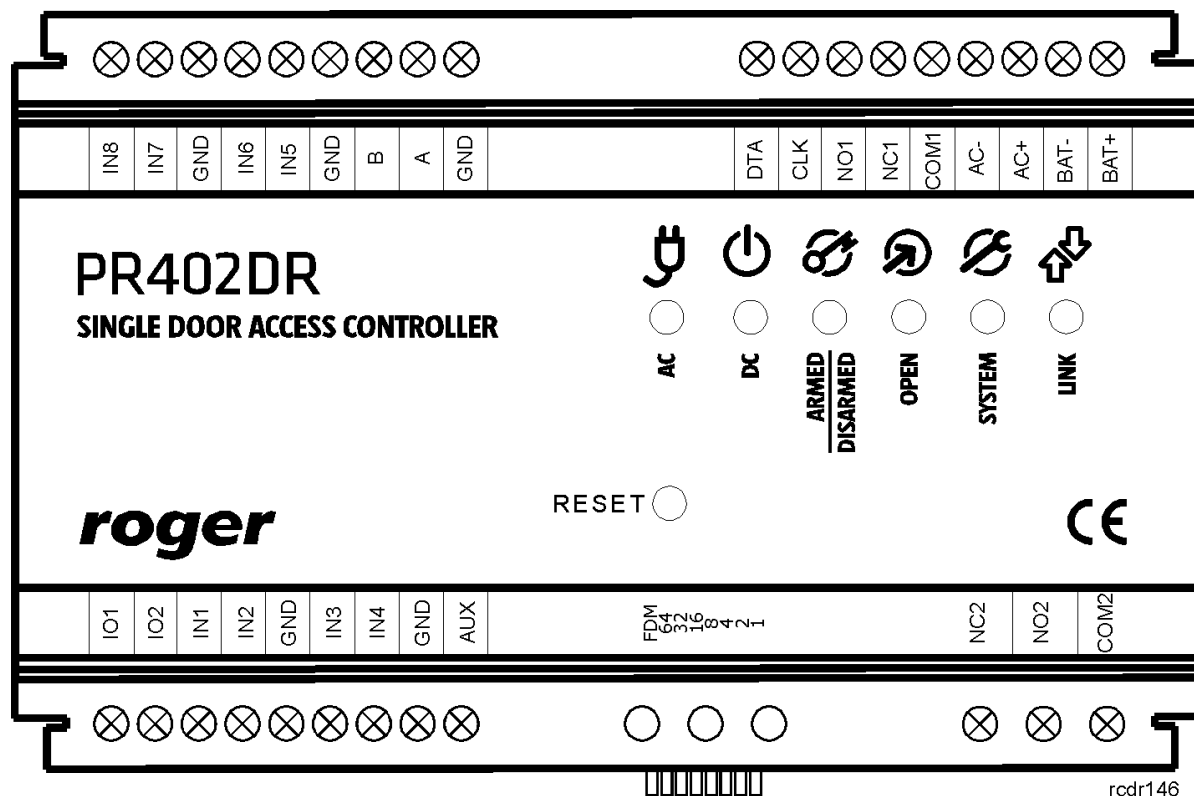
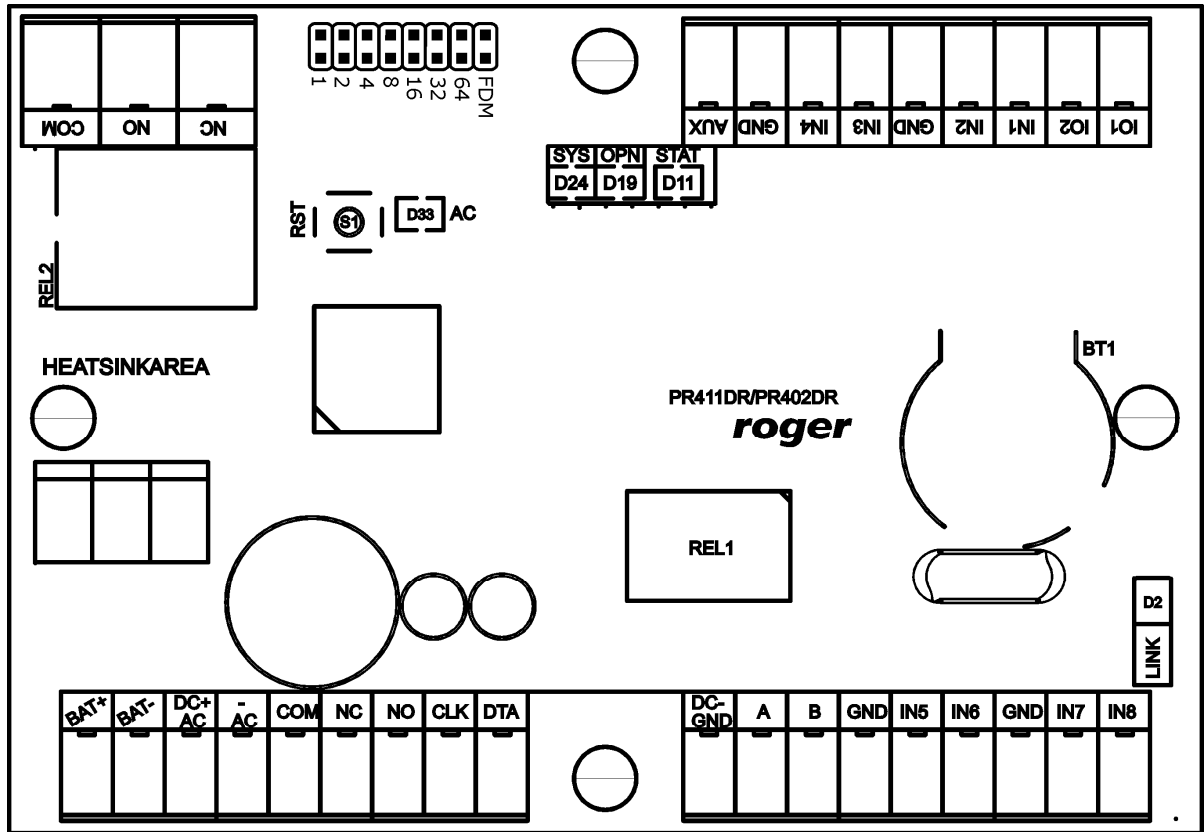

Fig. 1 PR402DR controller

Terminal	Description	Terminal	Description
IN8	IN8 input line	AC+	18VAC supply from transformer
IN7	IN7 input line	BAT-	Backup battery
GND	Ground	BAT+	Backup battery
IN6	IN6 input line	IO1	IO1 output line
IN5	IN5 input line	IO2	IO2 output line
GND	Ground	IN1	IN1 input line
B	RS485 communication bus	IN2	IN2 input line
A	RS485 communication bus	GND	Ground
GND	Ground	IN3	IN3 input line
DTA	RACS Clock&Data comm. bus	IN4	IN4 input line
CLK	RACS Clock&Data comm. bus	GND	Ground
NO1	REL1 relay output (NO)	AUX	Built-in feeder output (13,8V)
NC1	REL1 relay output (NC)	NC2	REL2 relay output (NO)
COM1	REL1 relay common terminal	NO2	REL2 relay output (NC)
AC-	18VAC supply from transformer	COM2	REL2 relay common terminal



rcdr148

Fig. 2 PR402DR-BRD controller

Table 2. PR402DR-BRD terminals			
Terminal	Description	Terminal	Description
BAT+	Backup battery	GND	Ground
BAT-	Backup battery	IN7	IN7 input line
DC+AC	18VAC supply from transformer	IN8	IN8 input line
-AC	18VAC supply from transformer	IO1	IO1 output line
COM	REL1 relay common terminal	IO2	IO2 output line
NC	REL1 relay output (NC)	IN1	IN1 input line
NO	REL1 relay output (NO)	IN2	IN2 input line
CLK	RACS Clock&Data comm. bus	GND	Ground
DTA	RACS Clock&Data comm. bus	IN3	IN3 input line
DC-GND	Ground	IN4	IN4 input line
A	RS485 communication bus	GND	Ground
B	RS485 communication bus	AUX	Built-in feeder output (13,8V)
GND	Ground	NC	REL2 relay output (NO)
IN5	IN5 input line	NO	REL2 relay output (NC)
IN6	IN6 input line	COM	REL2 relay common terminal

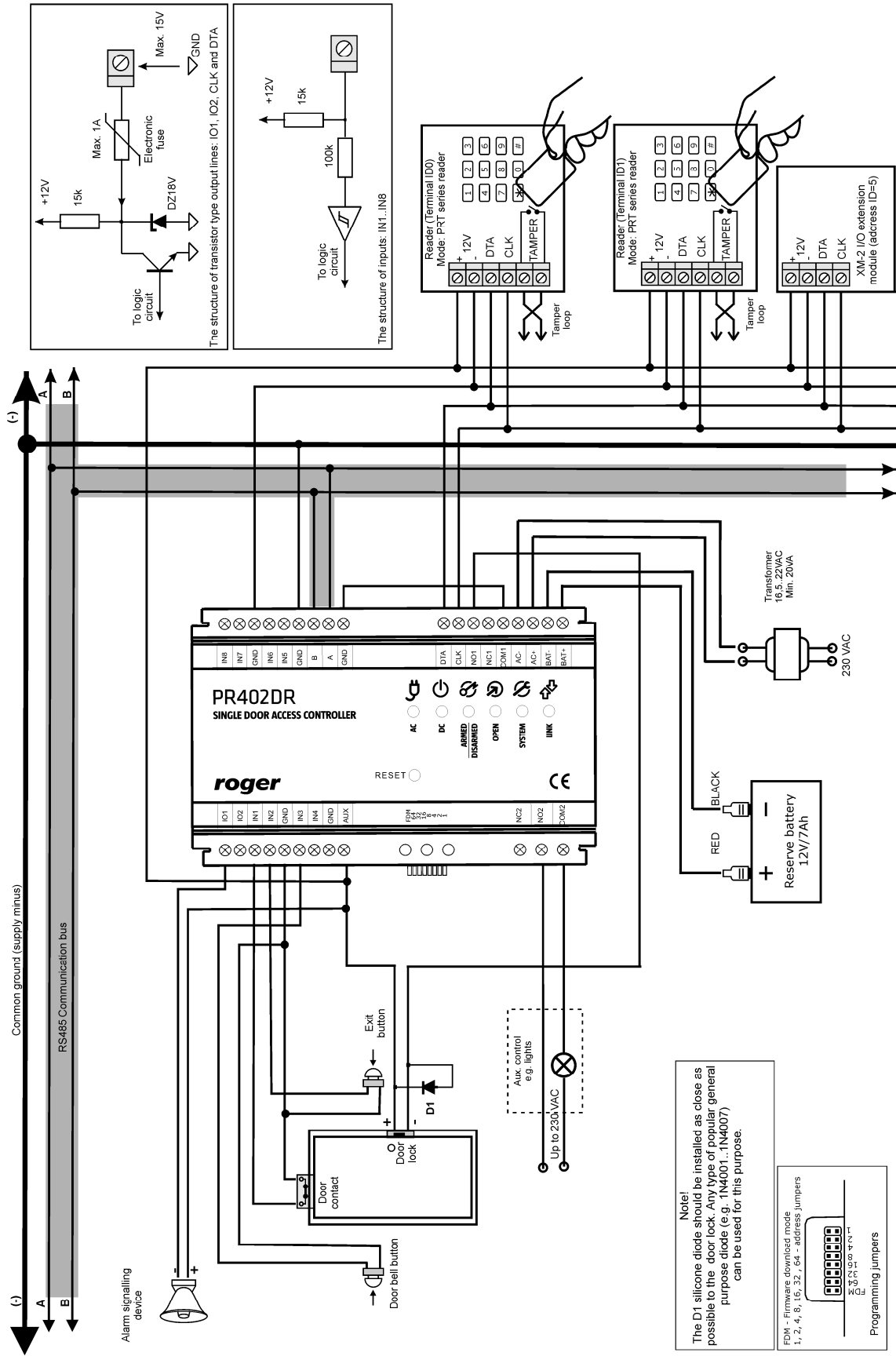

Fig. 3 PR402DR connection diagram

## 3.2 Front panel

### 3.2.1 PR402DR controller

According to fig. 4, the PR402DR controller is equipped with front panel to indicate various states of the device. RESET button is available at the front panel and it can be used to restart the controller in the same way as in case of powering device off and then on. The RESET button can also be used during Memory Reset procedure and during firmware update procedure.

<b>Table 4. PR402DR front panel</b>	
AC	AC supply
DC	DC supply
ARMED/DISARMED	Current arming mode
OPEN	Door unlocked
SYSTEM	Various signalling functions
LINK	Data transmission by means of RS485 bus

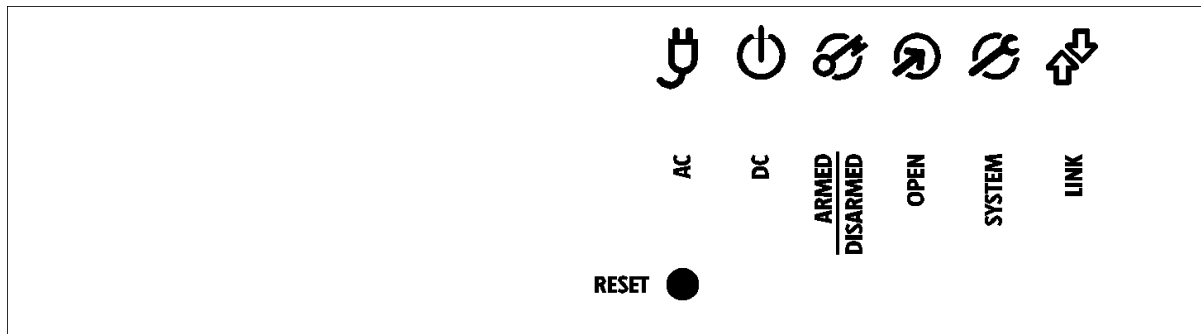

rcdr140

Fig. 4 PR402DR front panel

### 3.2.2 PR402DR-BRD controller

According to fig. 5, PR402DR-BRD is equipped with 5 LEDs and RESET button (S1) on its PCB. RESET button can be used to restart the controller in the same way as in case of powering device off and then on. The RESET button can also be used during Memory Reset procedure and during firmware update procedure.

<b>Table 5. LEDs at PR402DR-BRD controller</b>	
AC (D33)	AC supply
SYS (D24)	Various signalling functions
OPN (D19)	Door unlocked
STAT (D11)	Current arming mode
LINK (D2)	Data transmission by means of RS485 bus

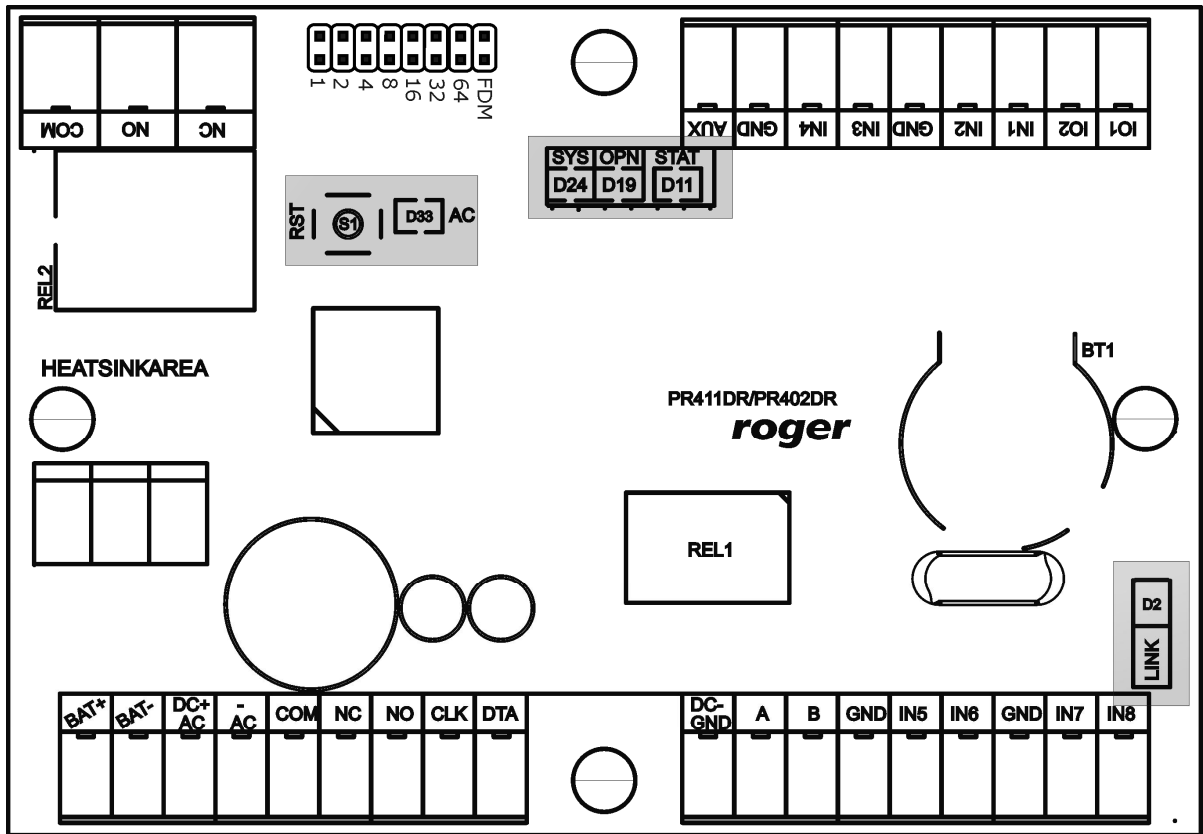

rcdr148

Fig. 5 LEDs at PR402DR-BRD controller PCB

### 3.3 Power supply

The controller can be supplied from 230VAC/18VAC transformer with minimal power output 20VA and connected to AC+ and AC- terminals ("+" and "-" polarity does not have to be observed). Alternatively, controller can be supplied with 12VDC (see fig. 6) or 24VDC (see fig. 7).

---

Note: It is recommended to equip 12 VDC or 24VDC power supply unit with UPS or backup battery.

---

When controller is supplied from DC voltage, it is forbidden to connect it either to AC transformer or backup battery. In such case, backup supply can be provided by connection of battery to the power supply unit, which provides 12VDC or 24VDC to the controller. It must be anticipated that controller and its auxiliary devices might require up to 1.5A of DC, which means that wires with adequate cross section must be used to ensure proper current supply.

---

Note: The controller cannot be operated if it is supplied only from backup battery. In such case, AC power supply must be also connected.

---

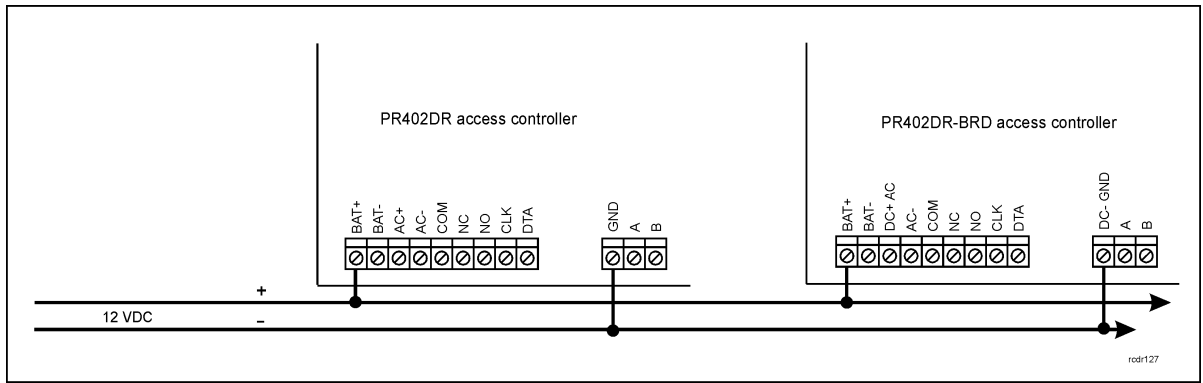

Fig. 6 Connection of 12VDC Power supply

Note: In case of 12VDC supply it is irrelevant which GND terminal is used

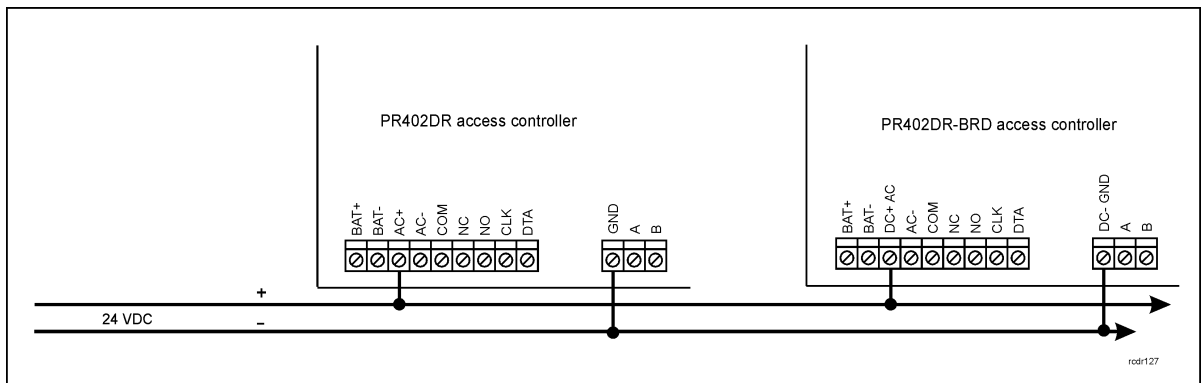

Fig. 7 Connection of 24VDC Power supply

Note: In case of 24VDC supply it is strongly recommended to use GND terminal near RS485 A terminal (according to fig. 7).

### 3.4 Connection of door lock

In majority of cases, door locking devices are inductive type. It means that turning off the current flow through the device causes the over voltage condition (voltage surges) which can interfere with the controller electronic components. In extreme cases it may result in improper operation of the controller or even freeze of the unit. Moreover, overvoltage condition causes quicker wear of the relay contacts. In order to limit this negative condition, it is necessary to utilize a general use semiconductor diode e.g. 1N4007 (one piece of such diode is delivered with the controller). It should be connected as close as possible to the inductive element (electric strike or magnetic lock). The door locking device can be supplied directly from the controller via AUX/GND terminals or by means of separate wires from the same power supply unit as controller. The latter solution is recommended.

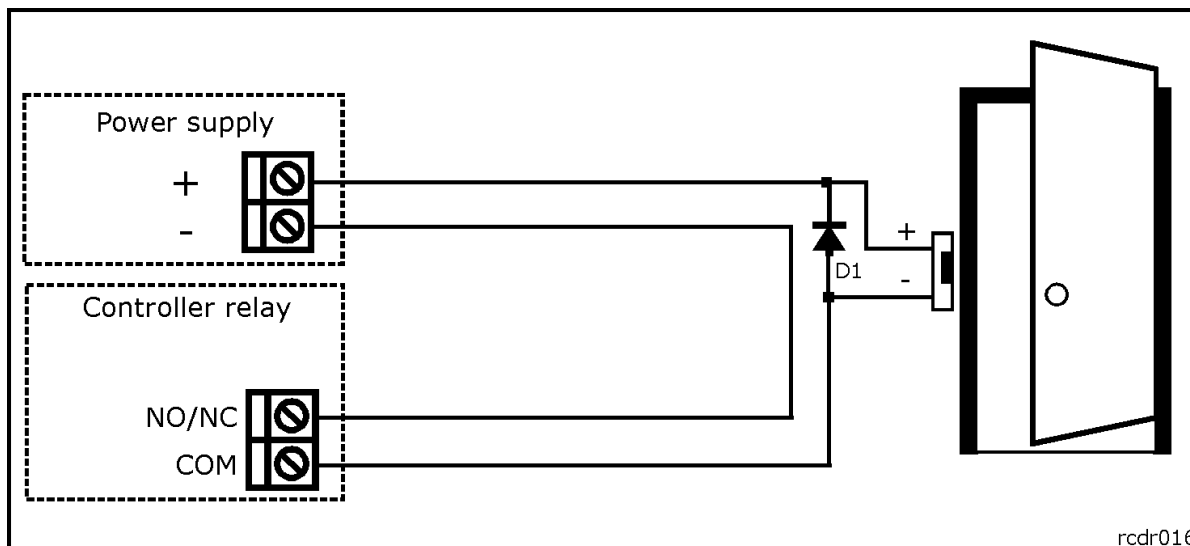

Fig. 8 Connection of door lock

### 3.5 Connection of readers and modules

Logically, PR402DR controller can operate with two access points (readers) which can provide two-way door control and are called Terminal ID0 and Terminal ID1. Terminal ID0 can be any PRT series reader configured to RACS Clock&Data mode with address ID=0 and connected to CLK/DTA lines or, any Wiegand type reader connected to IN1 and IN2 inputs. Data transmitted by any of these two readers is interpreted as transmission from Terminal ID0. Terminal ID1 can be any PRT series reader configured to RACS Clock&Data mode with address ID=1 and connected to CLK/DTA lines or any Wiegand type reader connected to IN3 and IN4 inputs. Data transmitted by any of these two readers is interpreted as transmission from Terminal ID1.

Up to four readers can be connected to the controller however logically they will be treated as two access terminals: Terminal ID0 and Terminal ID1. All readers can be activated or deactivated in within configuration software (PR Master).

---

Note: When working with Wiegand readers it is necessary to select adequate Wiegand data format, otherwise controller will not recognize transmissions from the reader. Data format can be selected by means of PR Master software.

---

#### 3.5.1 PRT series readers and extension modules

PR402DR controller can operate with two PRT series readers, single XM-2 extension module and up to four XM-8 extension modules (access to elevators), which are connected via CLK and DTA lines – see fig. 9. The PRT series readers can operate in various operating modes including Wiegand, Magstripe and RACS Clock&Data (Roger) however in case of operation via CLK and DTA lines they must be configured either to RACS Clock&Data mode with address ID=0 or RACS Clock&Data mode with address ID=1. Any type of cables (e.g. unshielded twisted pair) can be used for CLK and DTA lines. The guaranteed communication distance is 150 meters.

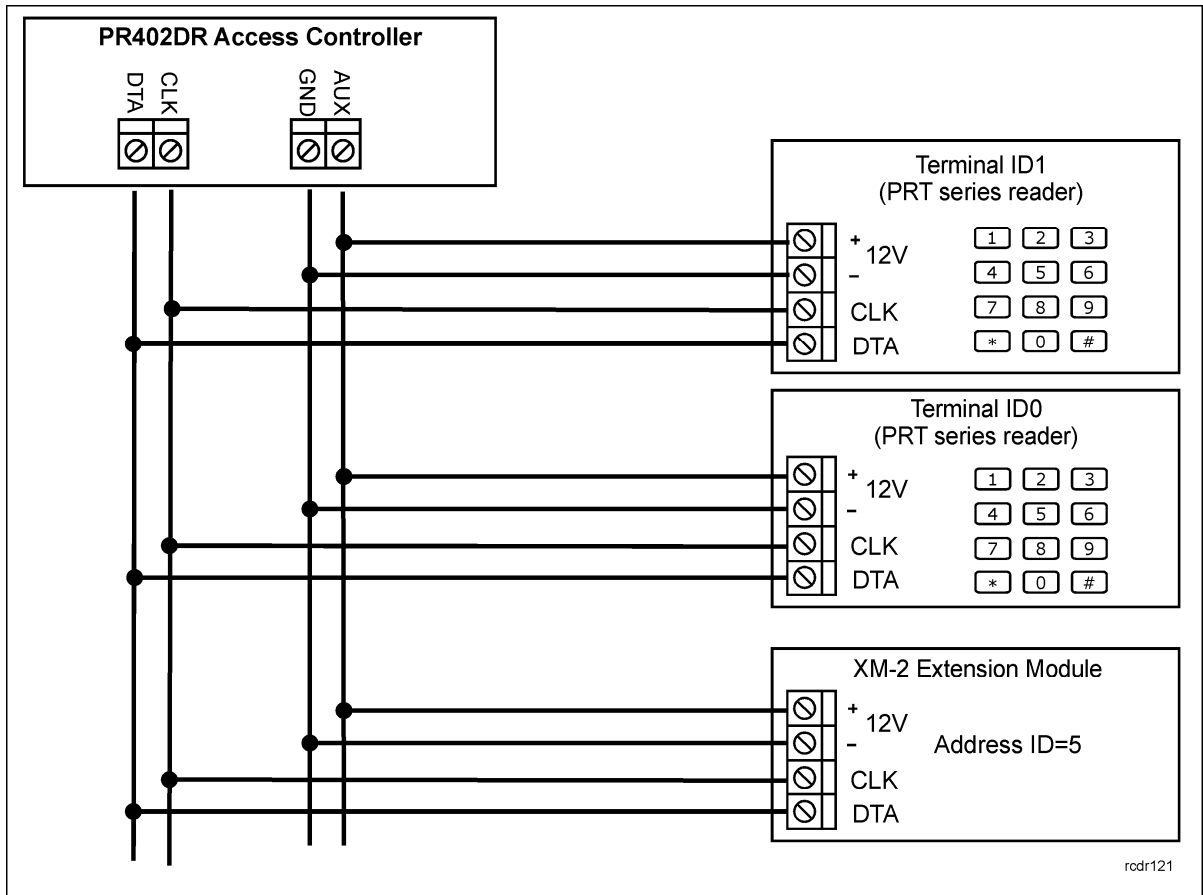

Fig. 9 Connection of PRT series readers and XM-2 module via CLK/DTA lines

Note: Practically, devices communicating in RACS Clock & Data standard (e.g. PRT readers) can be connected to the controller for significantly greater distances than 150m (even up to 500m), but the communication in such distance is not guaranteed by the manufacturer.

### 3.5.2 Wiegand readers

PR402DR controller can operate with various Wiegand type readers which transmit 26 to 66 bits of data in different data formats. The Wiegand readers should be connected to PR402DR controller in accordance with diagram shown in figure 10. Logically, data transmitted from the Wiegand reader connected to IN1 and IN2 lines are interpreted by controller as data received from Terminal ID0 while data transmitted from the Wiegand reader connected to IN3 and IN4 lines are interpreted as data received from Terminal ID1.

Note: If particular Wiegand reader does not work properly with controller, it might be necessary to use PR-GP module. The PR-GP works as electrical interface between reader and controller. In order to determine if PR-GP might be useful, please contact Roger technical support.

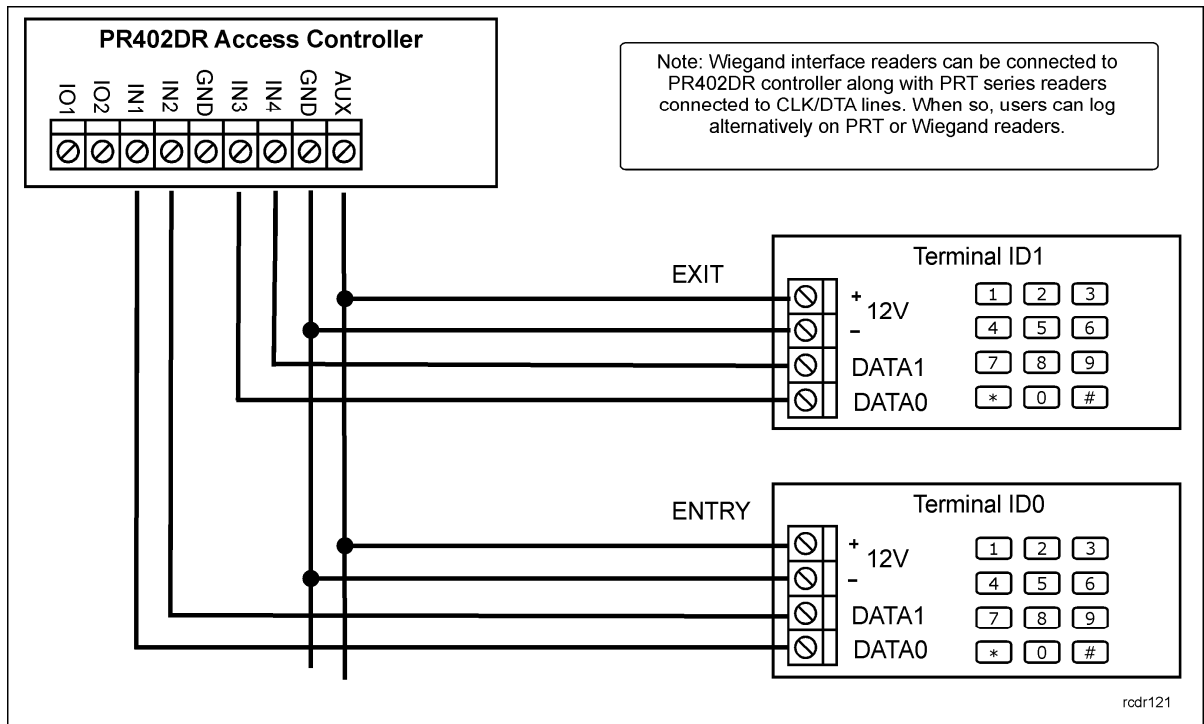

Fig. 10 Connection of Wiegand readers to PR402DR controller

### 3.6 Input and output lines

The functions are assigned to input and outputs by means of PR Master software. Default function for REL1 relay output is door unlock.

#### 3.6.1 Inputs

All inputs (IN1-IN8) of PR402DR controller have identical electric structure and can be configured as NO or NC lines. The NO input is triggered by shorting it to supply minus (GND) while the NC input must be normally shorted to supply minus (GND) and it becomes triggered when connection with ground is discontinued. Every input is internally connected (pulled up) to the power supply plus (+12V) through a 15kΩ resistor.

#### 3.6.2 Relay outputs

PR402DR controller provides two relay type outputs: REL1 and REL2. REL1 output offers one switched contact rated 30V/1.5A while REL2 output can be used to switch 230VAC and up to 5A. In the normal state (relay is off) the NC-COM contacts are shorted. In the triggering state (relay is on) the NO-COM contacts are shorted. In case of power outage, both outputs remain in the off state.

#### 3.6.3 General purpose outputs

Four transistor outputs (IO1, IO2, CLK and DTA) are available in PR402DR controller. All these lines are open collector type, i.e. in the normal (off) state are pulled to supply plus via 15kΩ resistor and when on, they short to supply minus. The IO1/IO2/CLK/DTA lines can switch current up to 1A DC while voltage connected to the output must not exceed 15VDC. In case of overcurrent state, transistor outputs are automatically switched off and the controller automatically restarts.

Note: The CLK/DTA lines can be used as general purpose outputs only if they are not used for connection with PRT series reader(-s) and/or XM-2 extension module.

### 3.7 RS-485 communication bus

The RS485 bus consists of two signal lines A and B. In the RACS 4 system any topology can be used (star, tree or any combination of them, except for loop) in order to connect controllers in network (subsystem) and to establish access control system. The matching resistors (terminators) connected at the ends of transmitting lines are not required. In most cases communication works

with any cable type (standard telephone cable, shielded or unshielded twisted pair etc.) but the recommended cable is unshielded, twisted pair (UTP). Shielded cables should be limited to installations subject to strong electromagnetic interferences. The RS485 communication standard used in the RACS 4 system guarantees proper communication in a distance of up to 1200 meters as well as high resistance to interferences. For the communication in longer distances it is required to use UT-3 or UT-4DR interface. A pair of UT-3 interfaces increases communication distance by another 1200 m while UT-4DR enables communication through a computer network (LAN or WAN).

### 3.8 Installation guidelines

- Install devices in such way as to ensure easy access to terminals and jumpers.
- Prior to controller installation it is recommended to set its address (ID number) – see 4.1 Controller address.
- The controller is delivered with MASTER proximity card, however any proximity card in EM 125kHz (UNIQUE) standard can be programmed as MASTER card.
- All electric cables must be connected to devices with disconnected power supply.
- All devices within RACS 4 system (controllers, readers, extension modules) should have common supply minus (GND). In order to ensure this, all the GND terminals from various power supply units used in the system (including access controllers with built-in power modules) should be connected with each other using separate wire. Alternatively, the common supply minus (GND) of the entire system can be earthed however in one, arbitrary selected, point only.
- A silicone diode of general use e.g. 1N4007 should be always connected in parallel to the door locking device (magnetic lock, electric strike, relay coil) — one piece of such diode is delivered with the controller. It should be connected as close as possible to the inductive element.
- It is recommended to supply door locking device by means of separate wires, directly connected to power supply unit.
- If door locking device is supplied directly from controller then some interference may occur and affect device operation.
- Readers can be installed on metal surfaces but in such case reduction of reading distance should be expected. The reading distance reduction effect can be minimized by installing readers on non-metal spacer with minimal thickness of 10 mm (e.g. PVC). The distance between two proximity readers should be min. 0.5 m. If two readers have to be installed on opposite sides of the same wall, it is recommended that they are not directly opposite (in the same axis). If this is not possible, a metal plate beneath each of them should be installed and additionally, an extra non-metallic spacer between reader and metal plate can be installed to improve reading distance.

### 3.9 PR402DR-BRD template in 1:1 scale

PCB template of PR402DR-BRD in 1:1 scale is presented in fig. 11, in order to specify mounting holes. All four holes are marked in grey. The module dimensions are 80mm x 115mm.

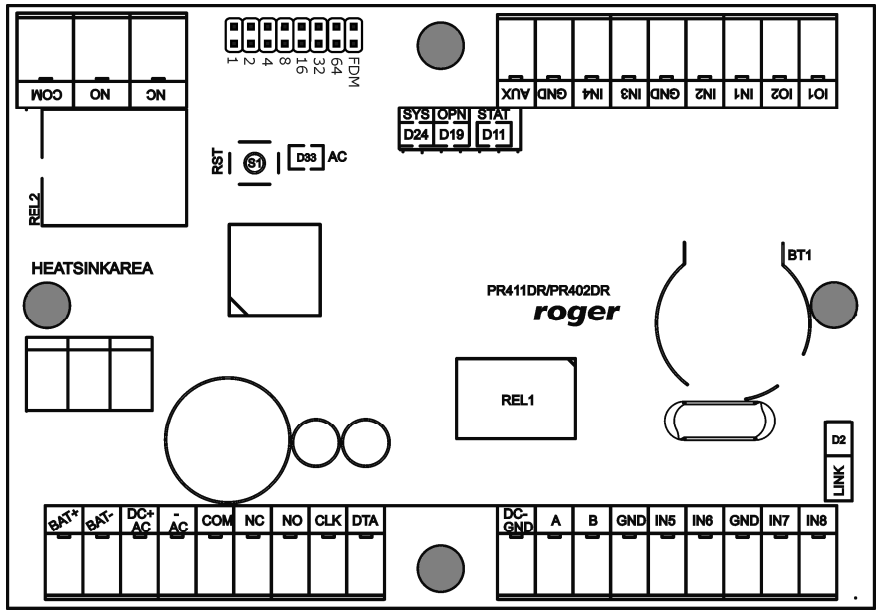

rcdr148

Fig. 11 PCB template of PR402DR-BRD in 1:1 scale

## 4. CONFIGURATION

### 4.1 Controller address

If the controller works as standalone device, then address setting can be skipped (default address ID =00) but if the controller is to be connected with other controllers by means of RS485 bus and operate in network system, then it is necessary to assign unique address to particular controllers (ID number from range 00..99). Two or more devices with the same address cause communication conflict and make a proper communication with these devices impossible.

There are four methods of setting controller address:

- During update of controller firmware by means of Roger ISP software (so called Fixed ID)
- By means of jumpers
- Manually, during Memory Reset procedure
- By means of PR Master software

The first two methods are called hardware addresses while the remaining two are called software addresses. The main difference between these two addressing methods is that software addresses can be changed either from the PR Master software or during Memory Reset procedure whilst hardware address cannot be changed in such way. Fixed ID has the highest priority, hardware address set with jumpers has lower priority and software addresses have the lowest priority.

---

Note: A new controller can be connected to the existing system without the necessity to change its address, but only if no other controller operates with default address ID=00. Once the controller is connected to the RS485 communication bus, it should be detected by means of PR Master software and required address can be set. It is recommended to assign addresses to all controllers as to make default address ID=00 unoccupied.

---

#### 4.1.1 Setting the address during firmware update (Fixed ID)

The so called FixedID can be set during update of the controller firmware by means of Roger ISP software. Prior to firmware upload, Roger ISP software offers the possibility to set Fixed ID address in range of 00..99. Once the FixedID is selected and uploaded to the controller it is not possible to change it until the next firmware update. If FixedID address is not required operator should select FixedID=None.

---

Note: When using FixedID address no other method except firmware update can be used to change controller address again. The FixedID address is maintained even in case of controller configuration error. Thanks to this feature controller can be always detected on the communication bus by means of PR Master software with the same address as it was assigned during firmware update.

---

#### 4.1.2 Setting the address by means of jumpers

If the controller has no FixedID then the address can be set by means of jumpers – see fig. 12. Each time the new address is set, controller must be restarted (via RESET button or powering device off and on) to make new settings active. The address range is 00..127 and if the address is in range 100..127 then the controller ignores such setting and software address can be used. If the address is in range of 00..99 then it has higher priority than software address and it cannot be changed by PR Master software nor manually during Memory Reset procedure.

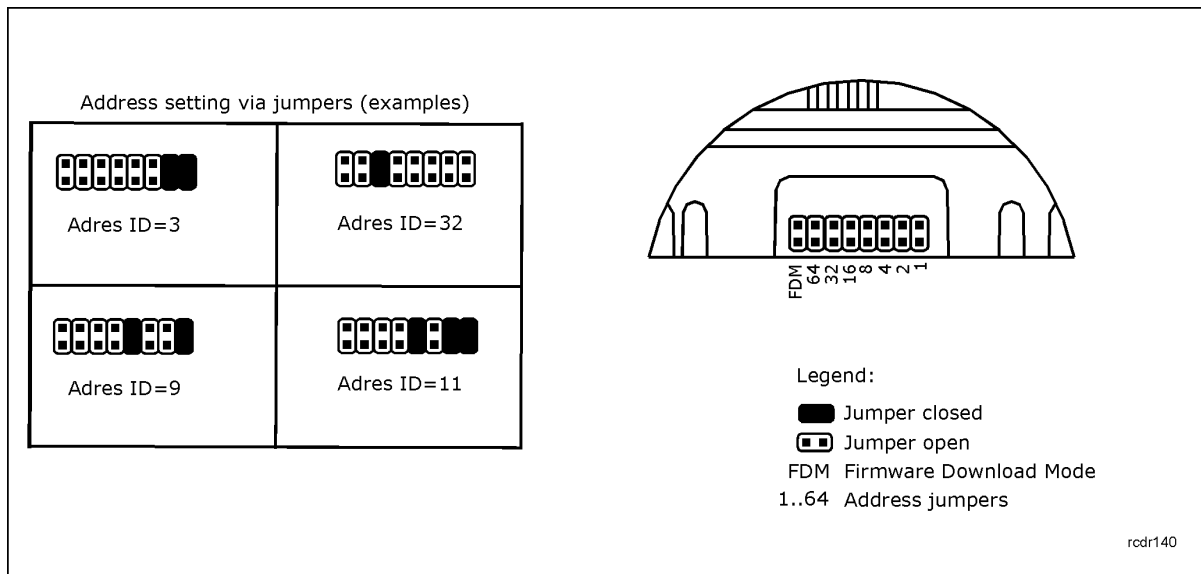

Fig. 12 Setting of controller address by means of jumpers

#### 4.1.3 Manual address setting during Memory Reset procedure

When hardware address is not used (i.e. FixedID=None and jumper address is set in range of 100..127) then the address can be set manually during Memory Reset procedure – see 4.2 Memory Reset.

Note: If controller works with Fixed ID or address is set by means of jumpers then Memory Reset procedure can be executed but still the software address shall be ignored.

#### 4.1.4 Setting the address by means of PR Master software

In order to set or change the address by means of PR Master software, the controller must be connected to PC via communication interface (UT-2, UT-2USB, UT4 or RUD-1) and detected by the software. Once, it is detected you can use Change ID command. In order to change controller address effectively by means of PR Master, the address set with jumpers at the controller must be in range of 100-127 – see 4.1.2 Setting the address by means of jumpers.

Note: The address, which is set manually during Memory Reset procedure can be changed by means of PR Master software and vice versa if the address set by means of jumpers at the controller is in range of 100-127.

## 4.2 Memory Reset procedure

Memory Reset procedure enables erasing of current settings and returning to default factory settings. It also allows to program new Master card/PIN as well as new address of the controller. After Memory Reset procedure, the controller automatically enters normal working mode and is set in Armed Mode (LED STATUS is red).

#### 4.2.1 Simplified Memory Reset Procedure

This method erases controller memory and allows for programming of MASTER card however does not allow to program the controller address (address is automatically set to ID=00) nor MASTER PIN. This procedure requires any PRT series reader connected to controller via CLK/DTA lines and the reader does not have to be equipped with keypad.



- Remove CLK and DTA wires from terminals
- Connect CLK and DTA terminals
- Restart the controller (press RESET button or switch power supply off/on) – all LED indicators shall be on
- Disconnect CLK and DTA terminals— the LEDs shall be off, and then LED OPEN (green) shall pulsate

- Connect any PRT series reader to CLK and DTA lines and execute further steps by means of that reader.
- While the LED OPEN  is pulsing, read any card at the reader — this will be a new MASTER card
- The controller restarts automatically and switches to normal mode with address ID=00

#### 4.4.2 Full Memory Reset procedure

This procedure requires PRT series reader equipped with keypad and connected to the controller through CLK and DTA lines. Full Memory Reset allows for programming of new MASTER identifier (card and/or PIN) and setting of controller ID address.

- Remove CLK and DTA wires from terminals
- Connect CLK and DTA terminals
- Restart the controller (press RESET button or switch power supply off/on) – all LED indicators become active
- Disconnect CLK and DTA terminals— the LEDs shall be off, and then LED OPEN  (green) shall pulsate
- Connect PRT series reader with keypad to CLK and DTA lines and execute further steps by means of that reader.
- Enter new MASTER PIN (3-6 digits) followed with the [#] key or skip this step just pressing the [#] key
- Read any card at the reader — this will be a new MASTER card or skip this step just pressing the [#] key
- Enter two digits (in range of 00 to 99) by means of keypad – this will be new ID address or skip this step just pressing the [#] key and then default ID=00 shall be set
- The controller restarts automatically and switches to normal mode

After Memory Reset, controller resumes its work with default factory settings and entered address. You can then initially test its operation using the MASTER card or PIN (if available). Using the MASTER card/PIN once activates the REL1 output for 4 seconds (LED OPEN  lights up for the time when REL1 is active). Using MASTER card/PIN twice switches the IO1 output to the opposite state and changes arming mode (LED STATUS  changes its colour).

---

Note: If the controller address is hardware type (see 4.1 Controller address) then address set during Memory Reset procedure is ignored.

---

### 4.3 Controller programming

PR402DR settings can be entered based on following methods:

- By means of PR Master software, which has to be installed on computer. The computer must be connected to the controller by means of communication interface (e.g. UT-2USB, RUD-1, UT-4DR). PR Master software is available at [www.roger.pl](http://www.roger.pl).
- By means of command entered with keypad. In such case PRT series reader with keypad is required and it must be connected to the controller (not all settings).

More information on controller programming can be found in the document – PRxx2 series access controllers, Functional description and programming guide and the document – PR Master User Manual, which are available at [www.roger.pl](http://www.roger.pl).

### 4.4 Firmware update

The latest version of firmware is available at [www.roger.pl](http://www.roger.pl). In order to update firmware it is necessary to connect the device by means of RS485 bus to communication interface (UT-2, UT-2USB, UT4 or RUD-1) and then connect the interface to PC with installed Roger ISP software. Roger ISP is available free of charge at [www.roger.pl](http://www.roger.pl).

#### Firmware update procedure

- Connect power supply to the device
- Place jumper on FDM contacts
- Reset the device (press RESET button or switch power off/on)

- Start RogerISP software and select communication port (in case of RUD-1 select RS-485).
- In Firmware window select firmware file (can be downloaded from [www.roger.pl](http://www.roger.pl)) and then select Program option.
- After firmware upload, remove jumper from FDM contacts and reset the device.

In case of network system, it is required to restart controller within PR Master software by right clicking particular controller and selecting the option – Restart controller and verify version.

## 5. ORDERING INFORMATION

<b>Table 6. Ordering information</b>	
PR402DR	PR402 advanced series controller in plastic enclosure adapted to installation on DIN 35mm rail
PR402DR-BRD	PR402 controller without enclosure – PCB module
XM-2-BRD	Input/output addressable extension module, which provides two NO/NC inputs and two relay outputs with single switched contact NO/NC rated 30V/1.5A. Communication with host device can be performed using CLK/DTA lines. The module can be located in a distance of 150 m from the host device (controller).
RM-2-BRD	Module with two relay outputs, rated 30V/1.5A each with single switched contact NO/NC. Relays can be triggered by applying low or high voltage signal. Triggering of relay is indicated by LED on the module's board.
XM-8-BRD	Input/output addressable extension module., which provides eight NO/NC inputs (disabled) and eight relay outputs. The module is dedicated for operations with PRxx2 series controllers as elevator access control module.
UT-4DR	Communication interface: Ethernet-RS485.
UT-2USB	Communication interface: USB-RS485.
UT-2	Communication interface: RS232-RS485.
RUD-1	Portable communication interface USB-RS485 with 12VDC output, which can supply connected controller.

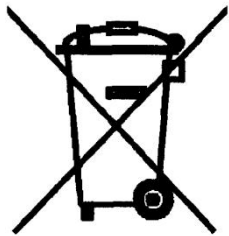
	<p>This symbol placed on a product or packaging indicates that the product should not be disposed of with other wastes as this may have a negative impact on the environment and health. The user is obliged to deliver equipment to the designated collection points of electric and electronic waste. For detailed information on recycling, contact your local authorities, waste disposal company or point of purchase. Separate collection and recycling of this type of waste contributes to the protection of the natural resources and is safe to health and the environment. Weight of the equipment is specified in the document.</p>
---	---

**Contact:**  
**Roger sp.j.**  
**82-400 Sztum**  
**Gościszewo 59**  
**Tel.: +48 55 272 0132**  
**Fax: +48 55 272 0133**  
**Tech. support: +48 55 267 0126**  
**E-mail: [biuro@roger.pl](mailto:biuro@roger.pl)**  
**Web: [www.roger.pl](http://www.roger.pl)**