

Voice and Digital
Telephone Alarm Dialer
DIAL 09 v4.0

Rev. A

INSTALLATION MANUAL

INTRODUCTION

Dialer construction and use

The dialer is a device used for automatic transmission of alarm messages (a fire, burglary, medical etc.). The dialer is capable of sending digitally coded messages to an alarm monitoring station, a text type message to pager system and a voice type message to telephone subscribers. Dialer can be fully programmed from keypad or, which is much more convenient, using a PC computer connected with the dialer through RS232C type serial interface. All the dialer configuration parameters and the voice messages are stored in non-volatile memories, which provide that the stored data is not lost in case the power is off. The dialer offer three inputs and two outputs, inputs and outputs can be configured for different options. The dialer can be configured for operation as a mini alarm control panel with digital and voice alarm transmissions.

The dialer enables you the following:

- sending information to two digital alarm monitoring stations
- sending information to two pager system subscribers
- sending information up to eight subscribers notified with an voice announcement
- remote, coded access to voice information on the dialer armed/disarmed condition
- remote and local control of the programmable outputs
- remote acknowledgment of the receipt of the announcement
- remote canceling of the alarm action and rearming of the dialer

The dialer is provided with the following features:

- a set of control codes of different authorization
- three universal NO/NC type inputs
- two programmable "open collector" type outputs
- RS232 communication interface
- PC software for easy device programming

The dialer monitors the following parameters:

- external line power supply voltage
- telephone line supply voltage
- the actual setting of real clock
- connection with a telephone network
- connection with alarm monitoring station(s)
- the contents of dialer's memory

DIALER INSTALLATION

You should hang the dialer on a vertical part of a structure element (walls), far from sources of heat and moisture. All electrical connections should be made prior to connecting the power supply voltage. After the full programming of the dialer, you are recommended to perform a simulation of the alarm action, possibly along with transmission of the codes to an alarm monitoring station.

Power supply connection

You should connect the dialer power supply cables to the terminals marked as +/- 12Vdc. The dialer requires DC power supply within 11 - 15 Vdc. The dialer is protected with polymer fuse which does not need replacement after fault condition. When you connect power supply to the unit for the first time, the dialer starts with the default (factory) values of the configuration parameters, default codes, without any pre-recorded announcements or pre-programmed message to a pager system station.

Telephone line connection

A telephone line should be connected to the dialer terminals marked with the caption "LINE". Other devices, which use the telephone line, should be connected to the terminals "TEL". Such a connection guarantees that the devices connected to the terminals "TEL" cannot disturb the dialer when operating with telephone line. The other devices (fax, modem etc.) using the telephone line can be also connected parallel with the dialer, i.e. to the terminals "LINE", but in this case they can disturb or even stop the dialing and alarm notification process.

Input line connection

There are three inputs of the dialer: A1, A2 and A3. All the dialer inputs have identical electric structure. Each of them can be configured as NO or NC. The alarm inputs are usually triggered with a contact, but it can be also triggered through applying a suitable voltage level. The line programmed as NO can be triggered by supply "minus" or by NO switch. Line configured as NC can be triggered by NC switch or by supply "plus", however when triggering by supply "plus" input should be previously connected with ground ("supply minus") by a resistor within the range from 0.5 to 2K Ω . For each of the inputs, during the dialer configuration process, the installer can set up the operating speed by defining the minimum duration time of the input triggering pulse (2s or 200ms) and assign a specific function (one of four available) for a certain output (see PI [43],[44],[45]).

NOTE!

You can assign the A2 and A3 inputs with some special functions, not available for the A1 input. The A2 input can perform a function of monitoring the AC voltage, whereas the A3 input can rearm dialer.

Connection of A2 line to monitor power supply AC voltage

You can configure the A2 line to monitor the power supply AC voltage in the network in which the dialer operates. In order to use the function, you should supply the A2 input with AC voltage from the secondary winding of the system supply transformer, as shown in Fig. 3 and perform necessary settings in the dialer configuration.

Connection of A3 line to control rearming of the dialer

You can configure the A3 line to operate as "Rearming input" function. In this case, you should supply the A3 input with a signal coming from the appropriate output of an alarm panel or coded lock.

Note: Rearming input is used to switch dialer between Armed/Disarmed modes. Only one input line can be defined to this function, when A3 line is configured as Rearming input no other method of Arming/Disarming of dialer is enabled.

Connection of PGM1 and PGM2 outputs

The dialer is provided with two programmable outputs: PGM1 and PGM2. The outputs are universal outputs of the open drain type of N-MOS transistor (1A dc continuous load capacity). Normally, the outputs are off (which corresponds the condition of high impedance). When switched on, the outputs deliver supply minus. The programmable output can be activated by different function. The maximum voltage which can be connected to PGM output may not exceed 16V level. The programmable outputs are protected against overvoltage and can control direct switching most of the available types of alarm signaling devices.

Headphone output

You can connect stereo headphones, equipped with a mini-jack stereo type plug of 3.5 mm diameter, to the dialer. Using the headphone, you can listen to the dialer voice messages which are recorded in dialer.

Switching on the power supply – dialer restart

After the power supply has been switched on the dialer resets real time clock and if jumper is located on Memory Reset it restores Factory (Default) settings.

The dialer do restart if:

- switching on the dialer power supply
- a momentary drop of the supply voltage below about 9 Vdc
- activation of the internal microprocessor WatchDog system
- after downloading from PC is completed

Default settings

The dialer is provided with a set of configuration parameters and codes, which are entered into the dialer's memory in the dialer manufacturing process. The settings are called default settings or factory setting. Default settings can be restored by performing the "Memory reset" procedure. The memory reset is usually preformed in case you do not know or remember the pre-programmed dialer codes or when you recognize the technical problem "Memory error".

Memory Reset – Return to default settings

When the memory is reset, the current dialer configuration is cleared and default settings are restored. After you have reset the memory, you should configure the dialer again, record the voice messages and program the text message to a pager station. You may reset the memory in the following two ways:

Memory reset – hardware method

1. Switch the dialer power supply off.
2. Place jumper on Memory Reset contacts.
3. Switch the dialer power supply on.
4. The dialer will generate a continuous tone, LED indicators will be pulsing.
5. Wait about 5 sec., dialer starts operation and move to ARMED or DISARMED mode
6. Remove the jumper from Memory Reset contacts.

Memory Reset – software method

1. Go to the INSTALLER PROGRAMMING mode.
2. Enter the [93][*][#] command.
3. The dialer will reset the entire memory.

DIALER PROGRAMMING

You can program the dialer using the dialer keypad or by performing a transmission from a PC computer. Programming can be divided into the following modes: USER PROGRAMMING and INSTALLER PROGRAMMING. You can enter the USER PROGRAMMING mode from both the ARMED and DISARMED mode and you need to know the user code [KU0]. You can enter the INSTALLER PROGRAMMING mode only from the USER PROGRAMMING mode and you need to know the installer code [KI]. During the dialer configuration process, the installer can disable access to many of the functions available in the USER PROGRAMMING mode and thus secure device against any problems resulting from the incompetent use or user's understanding of the available features of the dialer programming. Similarly, by changing the user code [KU0], the user of the dialer can secure himself/herself against uncontrolled access not to the USER PROGRAMMING and INSTALLER PROGRAMMING.

Acoustic Signals

During the dialer operation, the following acoustic signals may appear, which are generated by the internal electro-acoustic transducer of the dialer.

Error signal - symbol (-)

It is one long continuous tone of about 2-sec duration. The presence of the tone informs about a programming error or performing an forbidden operation. The tone is also transmitted when you enter the wrong code.

Encourage signal – symbol (** **)

These are two series of two short tones each. The encourage tone informs that the dialer awaits the next part of a command or code.

Operation end signal – symbol (*** ***)

These are two series of three short tones each. The operation end tone informs that the dialer has understood and performed the entered commands.

Note !

The above-described tones may also be heard in the telephone speaker, with which the dialer is communicating, and you should interpret them with the same principles as the tones generated by the dialer internal electro-acoustic transducer.

Abbreviations and terms used in the operating manual

AMS	A company providing alarm monitoring services by telephone.
AMS1	Alarm monitoring station #1.
AMS2	Alarm monitoring station #2.
RCT	Returned Call Tone. A tone, which you can hear in the speaker on the side of the subscriber who makes the connection. The tone informs that the connection has been established and the system awaits the answer of the called subscriber.

- Ring** Signal which is generated by a telephone exchange at the called subscriber to call him/her (telephone ringer).
- BT** Busy tone. A tone which is heard on the side of the subscriber who makes the connection. The tone informs that the dialed number is busy.
- TRC** Tone remote control. The function enables entering remote commands or instructions using DTMF tones.
- DC** Double call function. The function give priority to handle an external telephone call to other devices which use the telephone line together with dialer.
- DT** Dial tone. The tone can be heard after picking up the phone and means that telephone connection with a telephone exchange exists.
- PI[MN]-[K]** Installer programming function 'MN' option 'K'.
- PI[MN]** Installer programming function 'MN'.
- PU[N]** Installer programming function 'N'.

Hexadecimal notation system

With reference to some functions of the device, the HEXADECEIMAL notation system (HEX in short) is used. In the system, a number can be represented as a digit from the range 0,1...9 or a letter A, B, C, D, E and F. The digits 0, 1...9 have the identical meaning as in the decimal system, while the letters A, B, C, D, E and F correspond to the following numbers in the decimal system:

Character	Value	Programming method
A	10	[*][0][*]
B	11	[*][1][*]
C	12	[*][2][*]
D	13	[*][3][*]
E	14	[*][4][*]
F	15	[*][5][*]

LED indicators

The dialer is equipped with four LED indicators whose basic purpose is to signalize the current operating status of the dialer. In the programming mode the indicators are additionally used for visualization of the values of the programmed parameters. The LED indicators are assigned with the numbers 1, 2, 4 and 8. The read-out of the HEX number indicated by the LED's is performed by adding up the numbers next to the lit indicators. The digit zero is signalized by pulsing of all the LED's.

Example reading of the value of a number displayed in the HEX system.

The SYSTEM and PROGRAM LED's are on. The SYSTEM indicator corresponds to the number 8 and the PROGRAM indicator to the number 4, the presented number equals 8+4=12, which should be interpreted as the number "C" in the hexadecimal code.

TEL  LED INDICATOR

In addition to the mentioned LED indicators, the dialer is also provided with another (fifth) LED indicator, marked with a symbol of the telephone. When the indicator is on, it means that the dialer occupy telephone line.

DIALER OPERATION

The dialer is provided with two main operating modes: PROGRAMMING and READY. In READY mode, the dialer monitors the input lines, controls the PGM outputs and can communicate with monitoring stations and answer external calls. In the READY mode, there are two operating modes: ARMED and DISARMED. The difference between the two modes is that in the DISARMED mode the dialer does not monitor the inputs, which have been designated with the "Alarm input" function, and because of that it cannot enter the alarm condition. When the dialer enters the programming mode, it suspends telephone communication and does not monitor its inputs. Programming is divided into the following modes: USER PROGRAMMING , INSTALLER PROGRAMMING. Each of the dialer operating modes is signalized in a specific manner on the LED's.

Note: The transitions from ARMED into DISARMED mode or vice versa is defined as a "Rearming" of the dialer.

The methods of the dialer rearming is presented on the diagrams at the end of this manual.

Armed Mode

When dialer recognize that one or more Alarm Inputs are triggered it starts counting the delay before alarm (PI[46]) and when the delay time has elapsed it switches to the alarm condition. When dialer enters Alarm condition the ARMED LED starts blinks and continue this behavior until the dialer is disarmed. If dialer is disarmed before "delay before alarm" has elapsed, it will not enter alarm condition.

Disarmed Mode

In this mode dialer monitors all inputs except those which are configured as Alarm Inputs.

Alarm Signalization

Alarm may cause:

- alarm signalization at the output line,
- transmission of the alarm code to the proper AMS
- voice and/or text notification to preprogrammed subscribers.

Alarm Canceling

The alarm can be terminated by disarming. Disarming can be performed through any available method. After alarm is canceled the alarm signalization on PGM output is switched off and voice and pager notification is discontinued. Disarming the dialer does not stop communication with an alarm monitoring stations (ASM), the communication with ASM is continued until all codes are sent or the telephone call limit is reached.

Note: Any operations on the dialer keypad in Armed or Disarmed mode doesn't interrupt or even suspend the telephone communication process and dialer's input monitoring. The telephone communication with AMS stations is only interrupted after entering the dialer programming mode.

Arming/Disarming

Arming/Disarming of the dialer can be performed manually from keypad, remotely from telephone or through A3 input line if the line is configured as Arming/Disarming Control Input.

Arming/Disarming Through A3 Input

In order to control dialer's Armed/Disarmed mode through A3 lint the input must be configured as Arming/Disarming Control Input. When Arming/Disarming is controlled by input line the manual and remote Arming/Disarming methods are disabled. In such a case the dialer's codes [KU0],[KU1],[KU4],[KU5],[KU6] and [KU7] can be used only to clear alarm action (to stop an alarm action).

Depending on configuration of the A3 line as NO or NC, the following rules are valid:

When the A3 line is NC type:

- high voltage or open contact on A3 line sets dialer to ARMED mode
- low voltage or closed contact on A3 line sets dialer to DISARMED mode

When the A3 line is NO type:

- low voltage or close contact on A3 line sets dialer to ARMED mode
- high voltage or open contact on A3 line sets dialer to DISARMED mode

Manually Arming and Disarming

If the A3 input line is not programmed as Arming/Disarming Control Input you can Arm/Disarm dialer using codes entered from the dialer keypad (the [KU0] and [KU1] codes) or remotely via DTMF with the [KU0] code. Using the [KU0] code via DTMF must be enabled during installation (PI[71]-[4]). You can also disarm dialer using one-time use disarming codes (codes [KU4], [KU5], [KU6] [KU7]), those codes may be used via DTMF only.

Auto-Arming Option

When Auto-Arming option is set (see command 71 option 8) dialer permanently operate in Armed mode. Any attempt to disarm dialer by code results that dialer move to disarmed mode for very limited period (1-2 sec.) and then automatically return to Armed mode. When Armed-Disarmed modes are controlled by A3 input line the Auto-Arming option is ignored (the input line control device Armed/Disarmed condition).

Delayed Arming

Switching from the Disarmed to Armed mode occurs after a time delay (see command 48). During the delay both LED indicator Armed and Disarmed are on. The Delay before Arming can be set from 000 to 255 sec. When value 000 set, the dialer move from Disarmed to Armed mode without any delay. The delay before arming does not occur when dialer is armed remotely via DTMF.

Pause Between Alarms

The dialer can start handling another alarm at the moment when the telephone action of notification about the previous alarm has been completed, but not earlier than before the "Pause between alarms"(PI [47]) has elapsed. Programming the delay limits a possibility of entry to the alarm condition and can be an efficient protection against multiple telephone notifications caused by, for instance, a defect of a sensor or an alarm control panel. Rearming the dialer ends pause. When rearmed, the dialer is immediately ready to handle another alarm. When the time delay counting is stopped, the dialer sends the "Alarm Completed" (PI [43]) code to an AMS.

Telephone Alarm Action

The dialer can perform three types of notification about alarm:

- notification to an alarm monitoring station (AMS),
- notification of pager system subscribers with a text message,
- notification of the subscribers from the alarm list with a voice message.

Transmission to Alarm Monitoring Station (AMS)

Notification to a AMS station has the highest priority among the telephone communication types performed by the dialer and it is proceeded per a transmission protocol suitable for the monitoring station. Switching to other types of the telephone communication can be accomplished only after completion of communication with AMS stations.

Voice Message Transmission and Transmission to a Pager

In order to notify about the alarm condition, the dialer dials the numbers per their order in the alarm number list. You can put eight telephone numbers in the list. Two of them can be declared by the installer (PI[54] and PI[55]) as the numbers to pager system subscribers. The dialer sends a text message (PI[56]) to the pager system subscribers, whereas it transmits an voice announcement to the remaining subscribers from the alarm number list. During the telephone notification action, the dialer can perform 4 or 8 dialing cycles (PI[71]-[1]). During a dialing cycle, the dialer makes a single attempt of dialing each of the numbers in the alarm telephone list. If any telephone line is recognized as busy, the connection will be interrupted and the dialer goes to the next number. The action of announcement notification and the action of text message notification have an equal priority and is performed during the same cycle of dialing.

Transmission to Pager System

The dialer has to obtain one message transmission, confirmed by a pager system station out of the programmed (max. two) pager system subscriber. Confirmation of the message receipt by a pager system station, does not allow further attempts of the message transmission to the pager system subscriber who has already been notified.

Transmission to Voice-notified Telephone Numbers

During the action of voice announcement notification every of telephone subscribers has to be notified. During the configuration process, the installer specifies how many times each of them should be notified (PI[51]). A subscriber is qualified as notified, if the dialer, based on an analysis of electric signals, recognizes the moment of picking up the telephone. The dialer recognizes that the dialed subscriber picked up the phone if the returned call tone (RCT) disappears in the telephone line (the RCT signal is en "echo" of the ringing signal in called telephone). If the installer switches on the option which deactivates the pick-up detection (PI[50]-[8]), the dialer assume that each attempt of dialing is equivalent of notification. The option does not apply to notification of pager system subscribers. If during the telephone communication, the notified subscriber confirm receipt of message by pressing the [#] key (after encourage signal), the dialer assumes that the specific subscriber has been notified with 100% certainty and it does not dial the subscriber during the further process of the notification action.

End of Telephone Alarm Action

The dialer will stop telephone alarm action if:

- the voice message was send to all telephone numbers and text messages was send to pager station or
- the limit of dialing attempts has been reached maximum allowable number (4 to 8 attempts for every number),
- the dialer has been disarmed (using any of the methods allowed in the configuration),
- the dialer programming mode has been entered,
- the alarm action has been reset by the use of [KU3] code transmitted via DTMF.

Answering Incoming Calls

During the dialer configuration, installer specifies the number of rings after which the dialer can start handling the external call. The dialer does not handle any phone calls from outside when it is in the programming mode. At the beginning of connection initialized by an external call, the dialer transmits the encourage signal (** ***) and then waits for the [KU2] code to be given via DTMF. The dialer allows up to three attempts to enter the code. The third unsuccessful attempt results in disconnection form telephone line. If the dialer recognizes the [KU2] code, it transmits a triple announcement about the current operating mode (messages PI[57] and PI[58]) or alarm announcement in case the dialer has recognized the alarm condition since the last arming. After completion of the announcement transmission, it generates the encourage signal (** ***) and awaits additional commands via DTMF. Each time the user hears the signal, he/she can enter the commands described in the section "Remote control (TRC)". The communication with the dialer is quit when you use the [#] key after the encourage signal or automatically when no command is entered within 7 seconds.

Note: If the [KU2] code is programmed as a blank one (PU [*][6][2][#]), then during handling an external telephone call, the dialer does not require the above code and automatically transmits a message on the current operating mode and then it goes to waiting for a command to be given via DTMF.

Double Call Timer Function

In case the dialer recognizes in the telephone line the number of rings, which is equal with the number pre-declared in the configuration, then no matter if the Double Call function is on or off, the dialer connect into the telephone line and handles the call. However, if the recognized number of rings is smaller than the pre-set value in the configuration and the Double Call function is on, the dialer starts the process of counting pre-declared time delay. If, during this delay the dialer recognizes rings again, it does not wait for the required number of rings, but immediately after the second ring connects into the telephone line and handles the connection. This function enables other devices, which are connected to the telephone line along with the dialer, the priority access to receive a call and provides that any third parties do not see the presence of the dialer in the telephone line.

Note: When Double Call Timer value is set to zero the Double Call function is disabled.

You should remember that for the proper functioning of the DC function, none of the other devices sharing the telephone line with the dialer should take over phone calls from outside after recognition of fewer than two rings, because that way they will start operation prior to the dialer.

Remote Control via DTMF – TRC function

You can enter the dialer remote control in the following two situations:

- during telephone alarm action when dialer called you with voice message,
- during telephone connection which was initiated by incoming call,

When dialer is ready to accept remote command via DTMF it generates the **encourage signal** (** ***), this signal you can hear by your phone handset. The DTMF commands can be given by any device which generate a DTMF tone (standard DTMF phone, GSM phones or other equipment).

The Tone Remote Control function allows the following commands:

- [KU0][#] This command Arms/Disarms device, the use of this code via DTMF must be enabled by installer.
- [KU2][#] After dialer pick-up incoming call it wait for this code, entering this code enables user to start Tone Remote Control. The request for this code can be disabled by installer.
- [KU3][#] Stops the telephone voice alarm action to all telephone numbers (except communication to AMS).
- [KU4][#] Disarms the dialer, clears the alarm action. This code can be used only one time.
- [KU5][#] Disarms the dialer, clears the alarm action. This code can be used only one time.
- [KU6][#] Disarms the dialer, clears the alarm action. This code can be used only one time.
- [KU7][#] Disarms the dialer, clears the alarm action. This code can be used only one time.
- [#] When this signal is transmitted after voice alarm message dialer will not attempt to notify the particular user again. This command clears further telephone action to subscriber which confirmed the receipt of voice alarm message.
- [KU8][*][#] Sets the PGM1 output ON
- [KU8][#] Sets the PGM1 output OFF
- [KU9][*][#] Sets the PGM2 output ON
- [KU9][#] Sets the PGM2 output OFF

Note: The [KU8] and [KU9] codes can be used only in reference to outputs configured as [Controlled by [KU8/KU9] code] (see command 61 option 6 and command 62 option 6).

TECHNICAL PROBLEMS

The dialer tests selected parameters of its own electronic system and the telephone line. When the "SYSTEM" indicator is continuously on, it means that the dialer has recognized at least one technical problem. When the "SYSTEM" indicator pulses, it means that the dialer has recognized a new problem since the time of the last recognition of a technical problem (PU*[1]). When you exit the read-out function, it results in switching off pulsing of the "SYSTEM" indicator. The "SYSTEM" indicator goes off after the following:

- all technical problems have been solved,
- after an exit from the INSTALLER PROGRAMMING or
- after a restart of the dialer.

During the configuration process, the installer can switch off detection of certain technical problems. The existence of one or more technical problem can also be signalized at the PGM output.

Loss of Real Time Clock

This problem informs that the dialer has the wrong indication of the real time clock. The problem always appears after switching on the power supply. The problem can also show up as a result of a short power supply loss or after activation of the internal Watch Dog system. The problem disappears after programming a new clock setting, which can be performed in the USER PROGRAMMING mode or by a transmission from a programming computer.

Loss of Telephone Line Voltage

The dialer, being in the READY mode (ARMED or DISARMED), continuously checks the existence of the telephone line voltage. When a voltage loss is longer than 3 minutes, the dialer switches on the "Telephone line voltage loss" problem signalization. When the telephone number voltage comes back, the dialer immediately switches off the problem signalization. The problem can be also signalized at the PGM output.

No Dial tone (DT)

The problem is signalized when after connecting into the telephone line, the dialer does not recognize the dial tone (DT). The signalization is switched off, when the dialer recognizes the tone in the telephone line during the next communication attempt.

No Connection with AMS1

The dialer switches on signalization of the problem when it is not able to make a telephone connection or transmit codes to AMS1. The problem signalization is switched off when a successful transmission of codes to ASM1 has been completed.

No Connection with AMS2

The dialer switches on signalization of the problem when it is not able to make a telephone connection or transmit codes to AMS2. The problem signalization is switched off when a successful transmission of codes to ASM2 has been completed.

Data Memory Error

Signalization of this problem indicates that some errors have occurred in the data memory. As a result, a malfunction of the dialer may occur. To solve this problem you should reset the perform Memory Reset procedure and completely reprogram the dialer. If this does not help, you should return the dialer to the service for repair.

ROM Program Memory Error

When this error is signalized, it means that the ROM memory is damaged. When you recognize such a problem, contact the service to replace the ROM memory.

Lack of AC supply

The problem signalization may be obtained by the proper configuration of the A2 line and making an electric connection with the secondary winding of the dialer power supply transformer (Fig. 3). The problem signalization is turned on, when a loss of the monitored AC voltage is longer than 60 minutes. The signalization is switched off, when the voltage returns for longer than 5 minutes. Returns and losses of AC voltage can be reported with the suitable codes to an AMS. The codes are transmitted to an AMS parallel with switching on and off the problem signalization by the SYSTEM LED indicator.

DIALER CODES

All the dialer codes, except for the ([KU8] and [KU9], can have the length of 4 to 8 digits, the [KU8] and [KU9] must have 4 digits. Depending on the code type, its entry can be performed locally from the dialer keypad or remotely via DTMF or using both methods. You enter the code by pressing adequate digits and ending them with the [#] key. Each code can be disabled when it is programming as BLANK code.

*Example: In the USER PROGRAMMING, the command:
[*][6][2][#] - Programs the [KU2] code as a blank one and thus switches its off.*

Note: The dialer does not allow for programming two identical codes. If you try to program a code, which is identical as an existing one, the dialer will generate the "Programming error" acoustic signal.

[KU0] – Main code

You use the main code to rearm the dialer and allows you to enter the USER PROGRAMMING mode. This is the most privileged code and is used by the supervisor or the owner of the facility. After a previous permission (PI[71]-[4]) you can use it in the TRC remote control mode.

- [KU0][#]** - each time code is entered dialer move from Armed to Disarmed and vice verso
- [KU0][*][#]** - after this sequence dialer enters User Programming mode

Note: There is possibility of a use of technical means which allow other people to listen (spy) to the codes given via DTMF. The possibility is especially dangerous when the telephone line wires are lay down in not protected location with public access. Therefore, it is recommended to use the [KU0] code via DTMF (PI[71]-[4]) only in special occasions.

[KU1] – User Main Code

This code can be entered from the dialer keypad only, each time the [KU1] is entered dialer is toggled from Armed to Disarmed or vice verso. The [KU1] code is dedicated for users which are only authorized to Arm/Disarm dialer and are not authorized for programming.

[KU2] – Remote Access Code

It is used only via DTMF, user must enter this code at the beginning of connection with dialer during external call. If this code is programmed as a blank one (PU[*][6][2][#]) dialer does not require it during connection.

[KU3] – Cancels Telephone Alarm Action

It is used only via DTMF. Use this code to cancel alarm notification action to all voice and pager alarm subscribers.

[KU4], [KU5], [KU6], [KU7] – Disarming codes (one time use)

They can be used only via DTMF. These are single use codes, i.e. they are automatically removed from dialer after they are used. When you enter each of the codes, the dialer goes to the DISARMED mode. If the dialer is rearmed with the A3 line, entry of this code only resets alarm and does not rearm dialer. Due to the single use character of these codes, there is no danger of their repeated use in case they have been listened to by somebody else.

[KU8],[KU9] - PGM1 and PGM2 programmable output control codes

Unlike the remaining codes, these codes have a fixed length of 4 digits. They can be used both locally and remotely via DTMF. The codes control the programmable outputs which have been configured as "User controlled" (PI[61]-[6],PI[62]-[6]). The dialer accepts the following commands with reference to the programmable outputs:

[KU8][*][#]	Sets the PGM1 output ON for the pre-programmed time period (from 000 to 255 sec.). If the pre-programmed period is [000], the output will remain in ON state till the [KU8][#] command is entered.
[KU9][*][#]	Sets the PGM2 output ON for the pre-programmed time period (from 000 to 255 sec.). If the pre-programmed period is [000], the output will remain in ON state till the [KU8][#] command is entered.
[KU8][#]	Sets the PGM1 output OFF.
[KU9][#]	Sets the PGM2 output OFF.

[KI] – Installer code

The code allows you to enter the Installer Programming mode. To enter the mode, you should enter the [*][0][KI][#] command in the User Programming mode.

DIALER INPUTS

You can assign each of the dialer inputs with one of the functions available. An input function specifies the method of the dialer response to recognition of the input line release condition. The dialer inputs in the programming modes are not monitored.

Alarm Input

When dialer is armed, an active signal on Alarm Input triggers alarm action on dialer (dialer move to alarm mode).

Auxiliary Reporting Input

No matter if dialer operates in Armed or Disarmed mode an active signal on Auxiliary Reporting Input results that dialer connect to suitable AMS and transmit code of input. The Auxiliary Input can be used to monitor any other signal or situation which may occur in location where dialer is installed to AMS (e.g. technical alarm, water alarm, gas alarm, etc.).

Arm/Disarm Control Input

The input is dedicated to control dialer's Armed/Disarmed modes. When input line is configured to this option **no other methods of Arming/Disarming of dialer can be used**. The option can be assigned to A3 line only.

Please note the following rules when the A3 input line is configured to Arming/Disarming function:

If the input is pre-configured as NC:

- a high voltage in the input corresponds the ARMED mode,
- a low voltage in the input corresponds the DISARMED mode.

If the input is pre-configured as NO:

- a low voltage in the input corresponds the ARMED mode,
- a high voltage in the input corresponds the DISARMED mode.

AC Input

Configuration of the input to this function and making a connection in accordance with Fig. 3 allows the dialer to detect the presence of AC voltage in the power supply unit. The dialer signalizes an AC voltage loss when it lasts longer than 60 min, the signalization is switched off when the monitored AC voltage is back and lasts for longer than 5 min. The value of the voltage connected to the dialer's input may not exceed 24V AC.

Input Ignored

Electric conditions at the deactivated input line are ignored by the dialer.

PROGRAMMABLE OUTPUTS

You can configure each of the two programmable outputs of the dialer to one out of seven functions. A programmable function specifies a reason which switches on the output. You additionally program a delay for each of the outputs, which specifies a time for which the output should be activated. The output can be activated for a period of [000] to [255] sec., after which it automatically returns to be off. When the pre-programmed value is [000] sec., the output is switched on until cause of its activation disappears.

Output Disabled

An output remains permanently off (in high impedance). You can use the function for temporary deactivation of the output without a necessity of interrupting the existing electric connections.

Loss of Telephone Line Voltage

The output is switched on in case the dialer recognizes a telephone line voltage loss longer than 3 minutes. The output is deactivated after the output delay has elapsed or when the pre-programmed delay is [000], as soon as the telephone line voltage is back.

Dialer in Alarm

The output is activated when the dialer recognizes the alarm condition. The output is deactivated when the output delay has elapsed or in case the pre-programmed output delay is [000], when the dialer is disarmed or the alarm is reset.

Failed to Communicate with Monitoring Alarm Station

The output is activated if the dialer does not transmit the alarm report to an AMS station within 6 minutes from the moment the alarm was recognized. The output is deactivated when the output delay has elapsed or if the pre-programmed output delay is [000], when the dialer is disarmed or the alarm is reset.

Failed to Send Voice Message

The output is activated if the dialer has not received any acknowledged receipt of the alarm announcement (acknowledgement must be done via DTMF by means of the [#] or [KU3] entry) within 6 minutes from the moment the alarm was recognized or no transmission of notification was sent to any of the pager system subscribers. The output is deactivated when the output delay has elapsed or if the pre-programmed output delay is [000], when the dialer is disarmed or the alarm is reset.

Dialer Armed

The output is activated at the moment the dialer goes to the ARMED mode. If the pre-programmed output delay is [000], the output remains activated as long as the dialer remains in the ARMED mode.

Controlled by Code

The output is activated by the user by entering the [KU8][*][#] command for the PGM1 output or [KU9][*][#] for the PGM2 output. The PGM output is activated for the time of the pre-programmed output delay or when the delay is [000], for the time until the output deactivation command is entered, by [KU8][#] and [KU9][#] respectively. The output deactivation commands switch the output off regardless the pre-programmed delay. The PGM output control commands can be entered both locally from the dialer keypad and remotely via DTMF. The output, which has been configured to this function can be used remotely, for example, to switch lighting, control electric opening of gates, etc.

Technical Problem

The output is activated when at least one technical problem has been recognized. The output is deactivated when the output delay has elapsed or in case the pre-programmed delay is [000] as soon as all technical problems have been solved.

Communication with Alarm Monitoring Stations

The dialer may communicate with two AMS stations. Each of the stations has its individual telephone number, which is programmed by the installer. The dialer gets through to each of the stations per an individual transmission format. There are four modes of cooperation with AMS stations:

- STANDARD mode (all event codes are transmitted exclusively to AMS1),
- SPLIT mode (input line alarm codes are transmitted to AMS1, the remaining ones to AMS2),
- DUAL mode (all codes are transmitted to AMS1 and AMS2),
- BACKUP mode (codes are transmitted to AMS1 and if it is not possible, they are sent to AMS2).

AMS Transmission Formats

A transmission format determines a method which dialer use to send reporting codes to an AMS. Each of the pre-programmed AMS stations can have its individual transmission format. During a connection with an AMS dialer send an account code and report code.

Account Identification Code

The code consists of 4 HEX digits. If the digit zero is programmed, it means that the AMS will be skipped during a transmission (which is the case for formats 3/1 and 3/2). An identification number for each of the AMS stations can be different.

Report Code

If certain situations occur, the dialer generates report codes and stores them in the memory buffers (each monitoring station has its own buffer). When one or more codes appear in a buffer, dialer starts a process of dialing an AMS and then its transmission. An report code consists of 2 HEX digits. If the digit zero is programmed, it means that the AMS will be skipped during a transmission (which is the case for formats 3/1 and 4/1). If two zeros are programmed, the code is not transmitted to an AMS.

No Communication with AMS

If the dialer reaches the limit of AMS communication attempts (4 or 8 dialing cycles see INSTALLER PROGRAMMING) and successful transmission is not achieved, it resets all event codes in a buffer and enters the "AMS transmission failed" (PI[30] and [31]) code to it. The code is transmitted at the beginning of the next communication session to an AMS and means that the previous dialing attempt was unsuccessful. You should interpret a receipt of the code as a loss of an undefined number of codes, which were not sent to a monitoring station due to a lack of possibility of connecting with the station and consequently a lack of continuity of the facility monitoring.

AMS Buffer Overflow

Event codes transmitted to an AMS station are entered to the buffer of the appropriate station (max. 24 codes). In case the number of event codes exceeds the capacity of a specific AMS buffer, the "No memory available for new codes" (PI[23] and [24]) code is entered to the event buffer. You should interpret a receipt of this code as a loss of a certain number of event codes which could happen when the buffer was full or, in other words, as a loss of transmission continuity. New events are entered to the buffer only if the previously generated codes are transmitted and give space for the new generated codes.

End of Communication with Alarm Monitoring Station

A transmission to an AMS station is completed when all codes have been sent to the AMS or the transmission attempt limit (4 or 8 dialing cycles) has been reached. If the dialer goes to the user programming mode, it suspend communication with an AMS but after return to ready mode dialer resume communication with AMS and continue transmitting reporting codes. Entering installer programming mode clears all reporting codes waiting for transmission to AMS.

USER PROGRAMMING

You enter the USER PROGRAMMING mode by entering the [KU0][*][#] command and you can perform it from both the ARMED and DISARMED mode. In this mode, the dialer inputs and outputs are deactivated, monitoring to AMS and the function of external call response are out of service, the communication with AMS is suspended.

When you enter the command, the PROGRAM indicator goes on, the ARMED and DISARMED indicators go off. In this mode, the following functions are available:

[*][0][K][#]	Entry to the installer programming mode.
[*][1]	Display Technical Problem.
[*][2][N]	Programming telephone alarm number, the N digit specifies which telephone number will be programmed.
[*][3][N]	Display telephone alarm number, the N digit specifies which telephone number will be displayed.
[*][4]	Voice Alarm Message record.
[*][5]	Voice Alarm Message playback.
[*][6][N]	Code Programming, the digit N specifies which code will be programmed.
[*][7]	Setting Clock.
[*][8]	Display Clock.
[*][9][N]	Display Code, the digit N specifies which code will be displayed.
[*][#]	Exit from the user programming mode.

NOTE !









The access to some functions in User Programming can be disabled by installer during device configuration. An attempt to call the function which is disabled will result in error signalization. Contact installer to enable function(s) which can not be accessed.

[*][0][K][#] Entry to the installer programming mode

After this command dialer enters Installer Programming mode.

[*][1] Display Technical Problem

After entering the function, the dialer displays the HEX code of the technical problem, which it has recognized, on the LED's. Pressing [*] key, you go to displaying next recognized problem. The dialer leave the function automatically after the last problem is displayed or immediately after [#] key is pressed.

Leds	Description
	HEX 1 – a loss of clock, you must re-program clock.
	HEX 2 – no voltage in the telephone line, telephone line is disconnected. The detection of telephone line voltage can be disabled by installer.
	HEX 3 – no dial tone.
	HEX 4 – no connection with AMS1.
	HEX 5 – no connection with AMS2.
	HEX 6 – EEPROM data memory error. You can usually solve the problem by resetting the EEPROM memory and reprogram dialer.
	HEX 7 – ROM program memory error. To solve the problem, you need to return the dialer to the service or replace the ROM memory IC.
	HEX 8 – loss of AC power supply. The problem appears when a lack of AC voltage is longer than 60 minutes, the problems disappears after 5 minutes from the moment when AC supply returns.

[*][2][N][NUMBER][#] Programming of Nth telephone alarm number

During the dialer configuration, the installer specifies the dialing method as PULSE/DTMF (PI[50]-[4]). A telephone number can consist of 16 characters. You complete the number programming with the [#] key. Each entered digit or character are presented on the LED's in the HEX system. The dialer allows you to program eight numbers (N = 1...8). You delete a number from the list by programming it as a blank one:

[][2][N][#] – deletes the Nth telephone number*

In addition to the digits 0,1...9 , you can put the following special characters in a telephone number:

Special character	Method of programming	Function
HEX. B	[*][1][*]	Switches to alternate dialing system, i.e. from DTMF to PULSE or inversely
HEX. C	[*][2][*]	4-second break in dialing
HEX. D	[*][3][*]	waiting for a dial tone (DT)

Note: Dialer enables programming of eight telephone numbers, two of them can be declared as numbers to a pager, (see Installer Programming commands [54] and [55]). During the telephone alarm action dialer send text message to those two pager numbers instead of voice alarm message.

[*][3][N][#] Display the Nth telephone number

After entering the function, the LED's display the first digit of a telephone number in the HEX system. By pressing the [*] key, you can display the next digit of the number. The dialer automatically exits the function after displaying the last digit of the telephone number or immediately after you have used the [#] key.

[*][4] Recording of Voice Alarm Message

You can record an alarm announcement by speaking to the built-in microphone from a distance of about 20 cm. The announcement recording is finished and the function is abandoned automatically after 24 seconds. You can complete the announcement recording earlier by pressing the [#] key.

[*][5] Playback of Vice Alarm Message

You can listen to the alarm announcement using the headphone socket in the side wall of the dialer. The dialer terminates the announcement playback and exits the function automatically after the complete announcement has been played back or you can do it earlier by using the [#] key. Use stereo headphones with a stereo mini-jack plug (diameter 3.5mm).

[*][6][N][code][#] Programming Dialer's Codes

The digit N indicates which code will be programmed. The digits, which are entered during programming, are displayed by the LED's in the HEX format. The dialer does not allow to program two identical codes. Any attempt to program a code which already exists will result in the error signal.

Code Number	Short Name	Description
N=0	[KU0]	Main code.
N=1	[KU1]	User code.
N=2	[KU2]	When you enter the code at the beginning of the external call, you can listen to the dialer status announcement and then to go to the tone remote control mode,
N=3	[KU3]	he code resets the announcement notification action and pager system notification action,
N=4	[KU4]	Dialer Disarming code, can be used via DTMF, after first use code is automatically one-time only,
N=5	[KU5]	Disarming code, used via DTMF only, can be used only one time,
N=6	[KU6]	Disarming code, used via DTMF only, can be used only one time,
N=7	[KU7]	Disarming code, used via DTMF only, can be used only one time,
N=8	[KU8]	PGM1 output control code, can be used to set or clear output.
N=9	[KU9]	PGM2 output control code, can be used to set or clear output.

[*][7][HHMM][#] Setting the Clock

HH mean the hour and MM mean the minutes. The entered HHMM digits are displayed in the HEX. Example:

Example: [*][7]1243[#] – programs the time: 12 hours 43 minutes

[*][8] Display Clock

When you enter the function, the LED's present the first digit of the clock time in the HEX system. The next digits are displayed when you use the [*] key. The function is abandoned automatically after reading the last digit or you can do it at any time by pressing the [#] key.

[*][9][N] Display Nth Code

When you enter the function, the first digit of the Nth code in the HEX system is presented. You display the next digits with the [*] key. The function is accomplished automatically after reading the last digit of code or you can do it earlier by pressing the [#] key.

[*][#] Exit from programming

The dialer exits the programming mode and returns to normal operation.

INSTALLER PROGRAMMING

You can enter the installer programming mode only when dialer stay in User Programming mode.

[*][0][K][#]

When dialer stay in Installer Programming mode the LED PROGRAM and LED SYSTEM are on. In this mode, you can enter functions which will configure device. Each function can be accessed by entering two-digit numbers, e.g.:

- [21][*][1][*][1][#] - programs the reporting code for the A3 input as B1 (HEX),
[99][*][#] - starts a programming session from a PC computer.

There are three modes of entering the programming parameters:

Mode 1 – marked with one asterisk [*]

Installer must select only one option from the set of few (usually four) available options, dialer shows which option is selected on LEDs.

Mode 2 – marked with two asterisks [**]

Each listed option can be enabled or disabled autonomously. Dialer show on LEDs which options are enabled.

Mode 3 – marked with three asterisks [***]

Installer should enter one or more digits corresponding to programmed parameter, every digit entry is presented on the LEDs.

Programming Monitoring Stations

First Monitoring Station (AMS1)

Table with 2 columns: Command and MODE. Rows include [0][1][Telephone number][#], [0][1][#], [0][4][XXXX][#], [0][5][Data Format][#].

Transmission Formats to AMS:

- [0] - SILENT KNIGHT/ADEMCO SLOW, 10BPS (1400 HZ HANDSHAKE) 3/1,3/2,4/1,4/2 NON-EXTENDED
[1] - SESCOA, FRANKIN, DTI, VERTEX, 20BPS (2300HZ HANDSHAKE) 3/1,3/2,4/1,4/2 NON-EXTENDED
[2] - SILENT KNIGHT FAST ,20BPS (1400HZ HANDSHAKE) 3/1,3/2,4/1,4/2 NON-EXTENDED
[3] - RADIONICS (1400HZ HANDSHAKE) 3/1,4/2 NON-EXTENDED
[4] - RADIONICS (1400HZ HANDSHAKE) 3/1,4/2 NON-EXTENDED PARITY
[5] - RADIONICS (2300HZ HANDSHAKE) 3/1,4/2 NON-EXTENDED
[6] - RADIONICS (2300HZ HANDSHAKE) 3/1,4/2 NON-EXTENDED PARITY
[7] - DO NOT PROGRAM
[8] - SILENT KNIGHT/ADEMCO SLOW ,10BPS (1400HZ HANDSHAKE) 3/1 EXTENDED
[9] - SESCOA, FRANKLIN DCI, VERTEX, 20 BPS (2300HZ HANDSHAKE) 3/1 EXTENDED
[A] - SILENT KNIGHT FAST ,20BPS (1400HZ HANDSHAKE) 3/1 EXTENDED
[B] - RADIONICS (1400HZ HANDSHAKE) 3/1 EXTENDED
[C] - RADIONICS (1400HZ HANDSHAKE) 3/1 EXTENDED PARITY
[D] - RADIONICS (2300HZ HANDSHAKE) 3/1 EXTENDED
[E] - RADIONICS (2300HZ HANDSHAKE) 3/1 EXTENDED PARITY
[F] - DO NOT PROGRAM

Second Monitoring Station (AMS2)

Table with 2 columns: Command and MODE. Rows include [0][6][Telephone number][#], [0][6][#], [0][9][XXXX][#], [1][0][Data Format][#].

Monitoring Mode

- [1][1][Option][#] - MONITORING off
[1] - STANDARD (codes are transmitted to AMS1 onl)
[2] - DUAL (each code is send to AMS1 and to AMS1)
[4] - BACKUP (if transmission to AMS1 is not successful dialer sends codes to ASM2)
[8] - SPLIT (reporting codes of alarms/returns from inputs are transmitted to AMS1, the rest of codes are transmitted to AMS2)

[1][2][HHMM][#] The time of test transmission. [***]

Reporting Codes

Each event code transmitted to monitoring station consist of two digits in the HEX system, if you enter the [0] digit, it will be skipped during transmission.

- [2][0][Code][#] - "A1 input triggered"
[2][1][Code][#] - "A2 input triggered"
[2][2][Code][#] - "A3 input triggered"
[2][3][Code][#] - "AMS1 buffer overflow"
[2][4][Code][#] - "AMS2 buffer overflow"
[2][5][Code][#] - "Device armed by local command" (keypad or Armed/Disarmed Input line)
[2][6][Code][#] - "Device disarmed by local command" (keypad or A3 line)
[2][7][Code][#] - "Device armed by remote command" (via Tone Remote Control - DTMF)
[2][8][Code][#] - "Device armed by remote command" (via Tone Remote Control - DTMF)
[2][9][Code][#] - "Test transmission"
[3][0][Code][#] - "Failed to connect with AMS1"
[3][1][Code][#] - "Failed to connect with AMS2"
[3][2][Code][#] - "AC voltage lost"
[3][3][Code][#] - "AC voltage returned"
[3][4][Code][#] - "Alarm Action Accomplished" (transmitted when a pause after alarm has been passed)

[3][5][Code][#] - "Device restarted" [***]
 [3][6][Code][#] - "A1 input restored" [***]
 [3][7][Code][#] - "A2 input restored" [***]
 [3][8][Code][#] - "A3 input restored" [***]

Input's Configuration

Definitions:

Slow line - input line requires a triggering pulse min. 2 sec.

Fast line - input line requires a triggering pulse min. 0.2 sec.

NC line - input is normally shorted to ground, when contacts open input became triggered

NO line - input is normally open (unconnected), it became triggered when shorted to ground

Note: The inputs can be triggered by contacts or by voltage. Instead of use of a NO or NC contacts inputs can be triggered by applying supply "minus" or "plus".

[4][0][A1 Input Type][#] [*]
 [1] - NO / Slow
 [2] - NC / Slow
 [4] - NO / Fast
 [8] - NC / Fast

[4][1][A2 Input Type][#] [*]
 [1] - NO / Slow
 [2] - NC / Slow
 [4] - NO / Fast
 [8] - NC / Fast

[4][2][A3 Input Type][#] [*]
 [1] - NO / Slow
 [2] - NC / Slow
 [4] - NO / Fast
 [8] - NC / Fast

[4][3][A1 Input Function][#] [*]
 [1] - Input Ignored, input is not handled.
 [2] - Alarm Input, a triggering of this input when device is Armed will start alarm action.
 [4] - Auxiliary Reporting Input, a triggering of this input will cause code transmission to monitoring station only.
 [8] - Tamper Input (H24), no matter if dialer is armed or not a triggering of this input will start alarm action.

[4][4][A2 Input Function][#] [*]
 [1] - Input Ignored, input is not handled.
 [2] - Alarm Input, a triggering of this input when device is Armed will start alarm action.
 [4] - Auxiliary Reporting Input, a triggering of this input will cause code transmission to monitoring station only.
 [8] - AC Input, input is dedicated to monitor of a AC supply, for connection details see installation diagram.

[4][5][A3 Input Function] [*]
 [1] - Input Ignored, input is not handled.
 [2] - Alarm Input, a triggering of this input when device is Armed will start alarm action.
 [4] - Auxiliary Reporting Input, a triggering of this input will cause code transmission to monitoring station only.
 [8] - Arming/Disarming Control Input, this input will be used to Arm/Disarm dialer.

Time Delays

[4][6][XXX][#] Delay before dialer will start alarm action XXX=0..255 seconds. [***]
 [4][7][XXX][#] Pause after alarm action XXX=0..255 minutes. [***]

If you program [000] the next alarm can be handled as soon as the previous alarm action has been accomplished otherwise next alarm can be handled after Pause Delay has elapsed.

[4][8][XXX][#] Delay before arming XXX=0..255 seconds. [***]

Telephone Line Options

[5][0][Option][#] [**]

- [1] – wait 8 sec. for dial tone (normally 4 sec).
- [2] – when no dial tone continue dialing (normally when dial ton doesn't exist device will not continue dialing).
- [4] - DTMF dialing system (normally the pulse system).
- [8] - do not wait for phone pick-up, transmit voice message immediately after dialing of the phone number.

[5][1][X][#] Number of successful alarm voice transmissions required to end the notification action to each telephone number X=1...4. [***]

[5][2][X][#] Number of telephone rings before dialer will answer incoming calls X=0,1...9 , when you program "0" dialer will not serve incoming calls [***]

[5][3][XXX][#] Double Call Timer XXX=000...255 seconds (for details see Double Call Timer Function [***]
 [***]

Programming [000] disables Double Call Timer.

PAGER Station

[5][4][N][#] Defines the first number to a PAGER system from the alarm number list (N=1..8)
 [5][4][#] Switches off the first number to a PAGER system
 [5][5][N][#] Defines the second number to a PAGER system from the alarm number list (N=1..8)
 [5][5][#] Disable second number to a PAGER
 [5][6] Message to a PAGER

You program the message by entering a series of characters according to the following rules:

- [*][*] - switches the keypad to the letter mode,
- [0][*] - return from the letter mode to the digital mode,
- [N][*] - gets a left letter of the keypad in the letter mode,
- [N][#] - gets a right letter of the keypad in the letter mode,
- [N] - gets a middle letter of the keypad in the letter mode,
- [*] - enters a space in the digital mode,
- [0] - enters a space in the letter mode,
- [0][#][#] - ends the message in the letter mode,
- [#] - ends the message in the digital mode.

After you have entered the message programming function, the keypad is in the digital mode of entering the characters. The message may consist of maximum 128 characters.

Note: Dialer accepts may communicate with pager systems which use 1000hz Handshake and Kissoff signals.

System Status Voice Messages

- [5][7] Recording "Dialer Armed" message, the messages may last 3 s, after recording is accomplished dialer automatically reproduce recorded message.
- [5][8] Recording "Dialer Disarmed" message, the messages may last 3 s, after recording is accomplished dialer automatically reproduce recorded message.
- [5][9] Reproducing "Dialer Armed" voice message.
- [6][0] Reproducing "Dialer Disarmed" voice message.

Programmable Outputs

- [6][1][PGM1 Output Option][#] [*]
 - [0] - Output disabled
 - [1] - Loss of Telephone Line Voltage
 - [2] - Dialer in Alarm
 - [3] - Failed to communicate with monitoring alarm station
 - [4] - Failed to send voice message to all telephone numbers
 - [5] - Dialer Armed
 - [6] - Controlled by [KU8] code
 - [7] - Technical Problem
- [6][2][PGM2 Output Option][#] [*]
 - [0] - Output disabled
 - [1] - Loss of Telephone Line Voltage
 - [2] - Dialer in Alarm
 - [3] - Failed to communicate with monitoring alarm station
 - [4] - Failed to send voice message to all telephone numbers
 - [5] - Dialer Armed
 - [6] - Controlled by [KU9] code
 - [7] - Technical Problem
- [6][3][XXX][#] PGM1 output timer XXX=000..255 seconds. [***]

When you program [000], the output remains triggered for unlimited period, until the cause which switched it on will disappeared.
- [6][4][XXX][#] PGM1 output timer XXX=000..255 seconds. [***]

When you program [000], the output remains triggered for unlimited period, until the cause which switched it on will disappeared.

System Options

- [7][0][Option][#] [**]
 - [1] - disables the keypad for 1 min. period after three unsuccessful attempts of entering the code
 - [2] - disables detection of a telephone line voltage loss
 - [4] - disables entry to function of reprogramming the real time clock
 - [8] - disables recording of the voice alarm message
- [7][1][Option][#] [**]
 - [1] - the number of dialing attempts limited to eight (normally dialer four)
 - [2] - the alarm voice message repeated up to four times (normally voice message is repeated two times)
 - [4] - enable [KU0] user code for remote control (Tone Remote Control)
 - [8] - enable dialer's self-arming feature (after disarming dialer will automatically return to armed mode)

User Programming Options

- [7][5][Option][#] [**]
 - [1] - reprogramming of alarm number #1 disabled
 - [2] - reprogramming of alarm number #2 disabled
 - [4] - reprogramming of alarm number #3 disabled
 - [8] - reprogramming of alarm number #4 disabled
- [7][6][Option][#] [**]
 - [1] - reprogramming of alarm number #5 disabled
 - [2] - reprogramming of alarm number #6 disabled
 - [4] - reprogramming of alarm number #7 disabled
 - [8] - reprogramming of alarm number #8 disabled
- [7][7][Option][#] [**]
 - [1] - reprogramming of [KU0] code disabled

- [2] - reprogramming of [KU1] code disabled
- [4] - reprogramming of [KU2] code disabled
- [8] - reprogramming of [KU3] code disabled

[7][8][Option][#]

[**]

- [1] - reprogramming of [KU4] code disabled
- [2] - reprogramming of [KU5] code disabled
- [4] - reprogramming of [KU6] code disabled
- [8] - reprogramming of [KU7] code disabled

Event History

You can read the next digits by displaying them on the dialer LED's in the HEX system. The program displays the consecutive HH.MM digits. When the LED's pulse, it means that the specific event has not occurred since the event times were deleted (PI[85]).

[8][1] Display the time of the last recognized loss of the telephone line voltage.

- [*] - selection of the next digit,
- [#] - exit from the function.

[8][2] Display the time when last alarm action has begun.

- [*] - selection of the next digit,
- [#] - exit from the function.

[8][3] Display the time when last AC power failure occur.

- [*] - selection of the next digit,
- [#] - exit from the function.

[8][4] Display the time when dialer was Armed last time.

- [*] - selection of the next digit,
- [#] - exit from the function.

[85][*][#] Clear event's history.

Other

[9][0] [New KI][#] Programming a new installer code [KI].

[9][1]

Display installer code, each digit is presented on the LED's in HEX format.
[*] – the next digit.
[#] – exit from the function.

[9][2][*][#]

Disables entry to the installer programming mode, one the option is set it can be removed only by resetting the EEPROM Memory.

[9][3][*][#]

Restores default settings (factory settings).

[9][9][*][#]

Switch the dialer to Downloading Mode, one the device enters Downloading Mode it will leave it after power on/off or remote command from downloading computer. The communication between dialer and computer requires UT-1 interface cable.

[*][#]

Exit from the installer programming mode, when you enter the command, the dialer performs the restart procedure and enters standard operation mode.

DEFAULT (Factory) VALUES

The default values of the dialer's memory are restored each time you perform the "EEPROM RESET".

Telephone Number	Status	Reprogramming
#1	Not programmed	Enabled
#2	Not programmed	Enabled
#3	Not programmed	Enabled
#4	Not programmed	Enabled
#5	Not programmed	Enabled
#6	Not programmed	Enabled
#7	Not programmed	Enabled
#8	Not programmed	Enabled

First telephone number to pager station: Not programmed
 Second telephone number to pager station: Not programmed

Telephone Line Options

- Wait 4 seconds for dial tone
- Wait for dial tone
- Pulse dialing system
- Wait for phone pick-up
- [KU0] usage via DTMF (Tone Remote Control feature) disabled
- Send Alarm Voice Message two times to each telephone number
- Answer incoming calls after 4 rings
- Double Call Timer disabled

Text message to a Pager station: Not programmed

Codes:

CODE	DIGITS	REPROGRAMMING
[KU0]	[0000]	Enabled
[KU1]	[1111]	Enabled
[KU2]	[2222]	Enabled
[KU3]	[3333]	Enabled
[KU4]	[4444]	Enabled
[KU5]	[5555]	Enabled
[KU6]	[6666]	Enabled
[KU7]	[7777]	Enabled
[KU8]	[8888]	Enabled
[KU9]	[9999]	Enabled
[KI]	[1234]	

TIME DELAYS

Delay before arming : 0 sec.
 Pause after alarm action : 0 min.
 Delay before dialer will start alarm action : 0 sec.

SYSTEM OPTIONS

Do not disable keypad after three unsuccessful attempts of entering code
 Do not disable telephone line voltage detection
 Enabled clock re-programming
 Enable voice alarm message recording
 Four dialing attempts for each telephone number
 Voice Alarm Message repeated four times
 Auto-Arming disabled

Monitoring Stations

Communication Mode : Communication to AMS disabled
 Telephone number to AMS1 : Not programmed
 Account number to AMS1 : 000
 Format of transmission to AMS1 : SILENT KNIGHT/ADEMCO SLOW
 Telephone number to AMS2 : Not programmed
 Account number to AMS2 : 000
 Format of transmission to AMS2 : SILENT KNIGHT/ADEMCO SLOW

Reporting Codes

All reprting codes set to [00]
 Test Transmission Time :00:00

Voice Messages

Voice Alarm Message : Not recorded
 Dialer Armed Message : Not recorded
 Dialer Disarmed Message : Not recorded

Event's History

Time of telephone line voltage loss	: Empty
Time of last entry to armed mode	: Empty
Time of last alarm action	: Empty
Time of AC voltage loss	: Empty

TECHNICAL SPECIFICATION

Power supply voltage	11..15 Vdc
Supply current	max. 100mA
Dialing system	DTMF/PULSE
Operating temperature range	0-50 °C

DRAWINGS

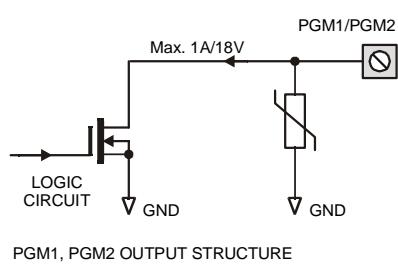
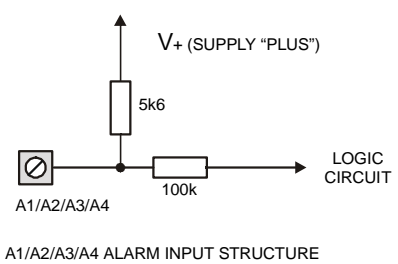
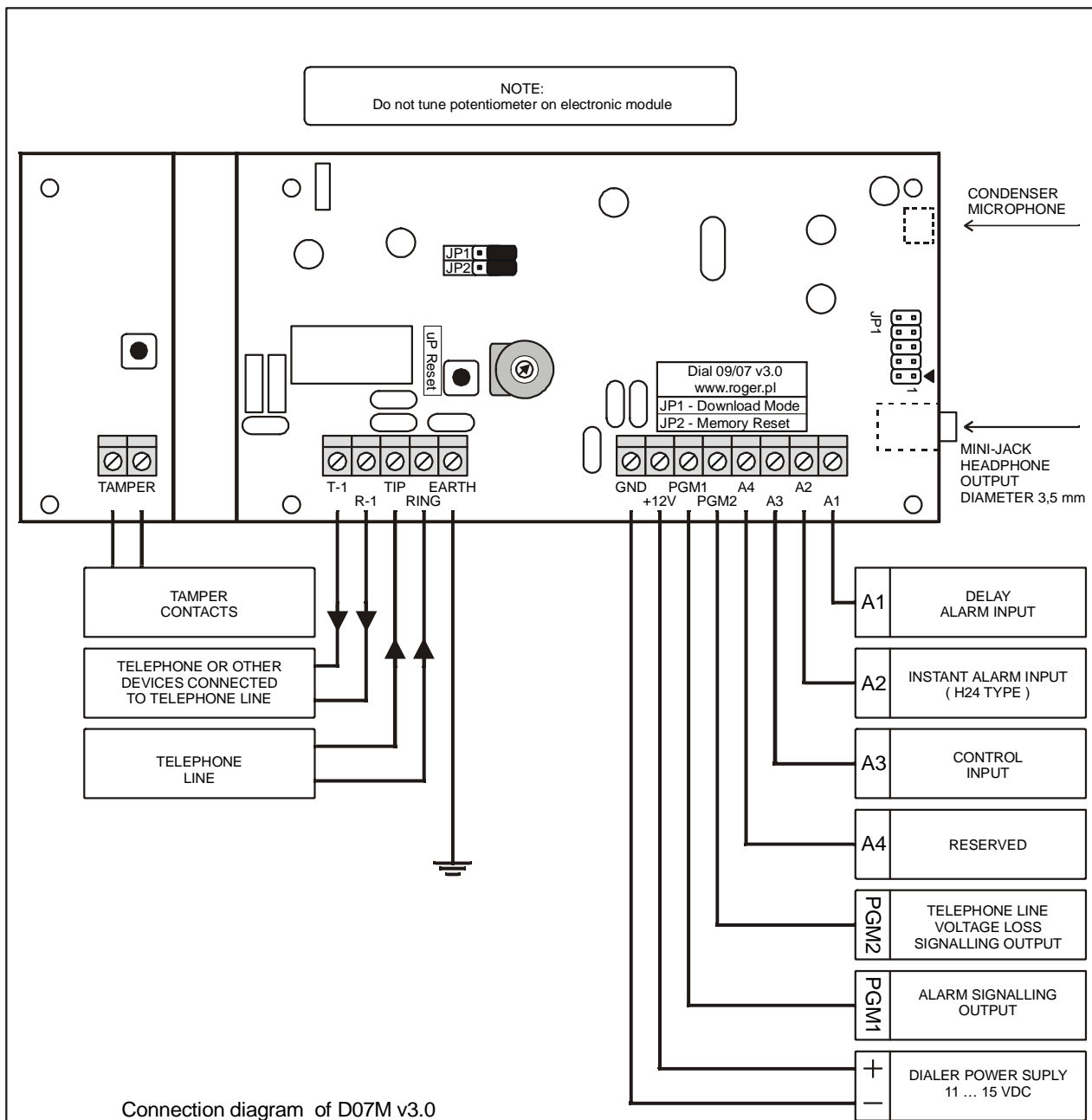

SCHEMATIC OF CHANGING THE DIALER OPERATING MODES WHEN THE DIALER IS REARMING WITH CODES

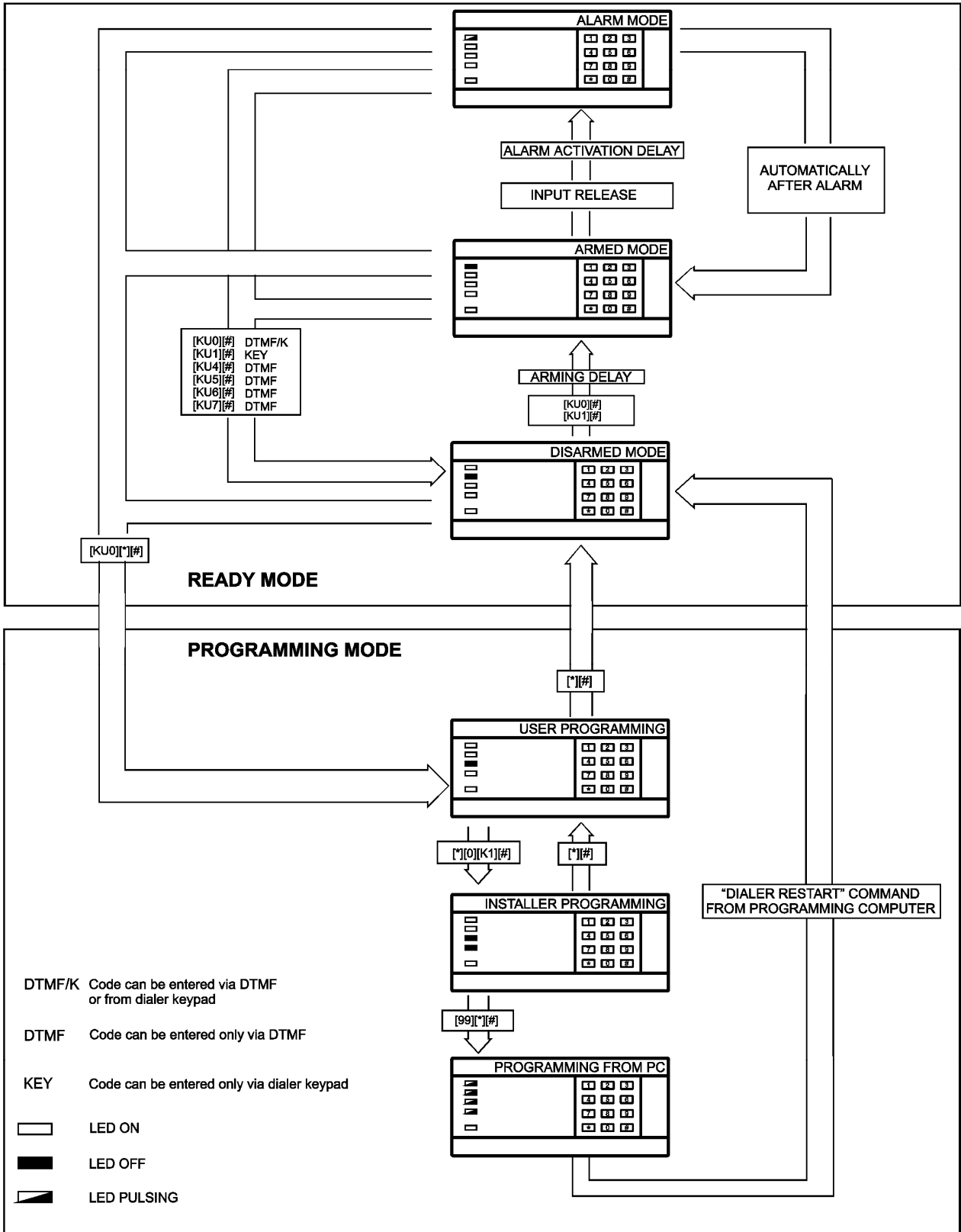

SCHEMATIC OF CHANGING THE DIALER OPERATING MODE WHEN REARMING IS PERFORMED WITH A3 LINE

